

**CATALOGO PARTI DI RICAMBIO**  
**CATALOGUE OF SPARE PARTS**  
**CATALOGUE PIECES DE RECHANGE**  
**ERSATZTEILKATALOG**  
**CATALOGO DE PIEZAS DE REPUESTO**



Le presenti immagini e i contenuti sono di esclusiva titolarità di Betamotor S.p.A., che si riserva tutti i relativi diritti. Non è consentita alcuna riproduzione, modifica, elaborazione, divulgazione, comunicazione, utilizzazione economica in ogni forma e modo, originale o derivato, che non sia espressamente consentita per iscritto da Betamotor S.p.A. Qualsiasi violazione sarà perseguita da parte di Betamotor S.p.A. in tutte le opportune sedi civili e penali.

*The images and content herein are the exclusive property of Betamotor SpA, which reserves all rights thereto. Any reproduction, modification, editing, dissemination, communication, exploitation in any form and way, original or derived, is strictly forbidden if not expressly approved in writing by Betamotor SpA. Any violation will be actively pursued in all relevant civil and criminal forums by Betamotor SpA.*

Toutes les images et le contenu qui se trouvent dans ce document sont la propriété exclusive de Betamotor SpA, qui se réserve tous les droits. Toute reproduction, modification, édition, diffusion, communication, ou exploitation sous quelque forme et de quelque manière, originale ou dérivée, est strictement interdite sans l'autorisation écrite expresse de Betamotor SpA. Toute violation sera poursuivie par Betamotor SpA dans toutes les cours civiles et pénales compétentes.

*Die vorliegenden Abbildungen und Inhalte sind Alleinbesitz von Betamotor S.p.A., die sich alle diesbezüglichen Rechte vorbehalten. Ohne die ausdrückliche schriftliche Genehmigung von Betamotor S.p.A. ist keine Art von Reproduktion, Änderung, Verarbeitung, Verbreitung, Mitteilung an Dritte, wirtschaftliche Nutzung in jeder Form und auf jede Art, weder im Original noch davon abgeleitet, erlaubt. Jede Zuwiderhandlung wird von Betamotor S.p.A. über alle zuständigen zivil- und strafrechtlichen Gerichtsstellen verfolgt.*

Las imágenes y el contenido de este documento son propiedad exclusiva de Betamotor SpA, que se reserva todos los derechos. Cualquier reproducción, modificación, procesamiento, difusión, comunicación, explotación en cualquier forma y manera, originaria o derivada, está estrictamente prohibidas si no están aprobadas expresamente por escrito por Betamotor SpA. Cualquier violación será perseguida por Betamotor SpA en todas las sedes competentes civiles y penales.

TAV.01A Carter completo - Crankcase, assy - Carter complet - Kurbelwellengehäuse, KPL. - Carter completo

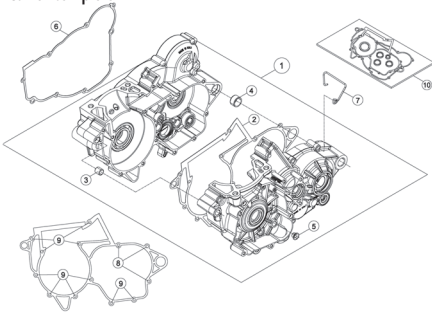

Pag. 6

TAV.01B Coperchio frizione - Clutch cover - Couvercle d'embrague - Kupplungsdeckel - Tapa embrague

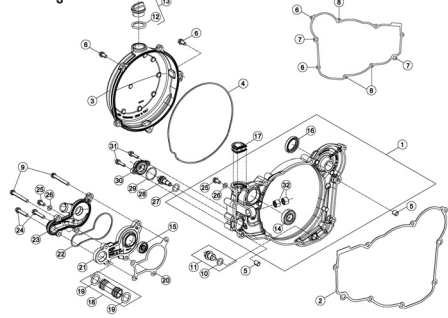

Pag. 8

TAV.01C Collettore aspirazione - Intake manifold - Collecteur aspiration - Ansaugstutzen - Colector aspiración

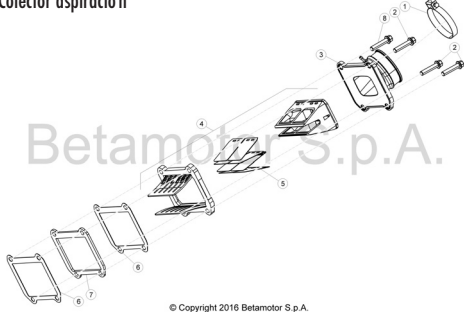

© Copyright 2016 Betamotor S.p.A.

Pag. 9

TAV.02 Albero motore - Crankshaft - Vilebrequin - Kurbelwelle - Cigüeñal

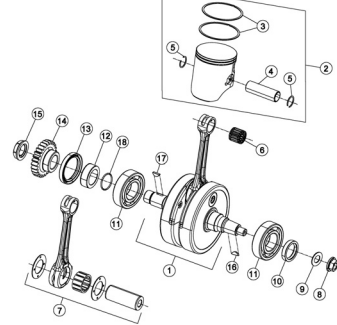

Pag. 10

TAV.03 Frizione - Clutch - Embrayage - Kupplung - Embrague

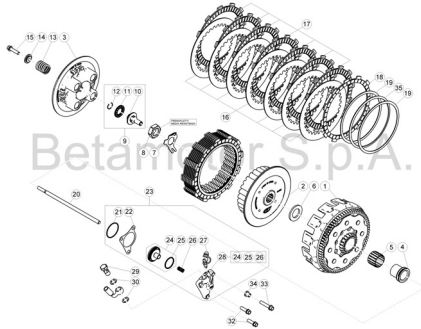

Pag. 12

TAV.04A Albero primario - Main shaft - Arbre primaire - Hauptwelle - Arbol primario

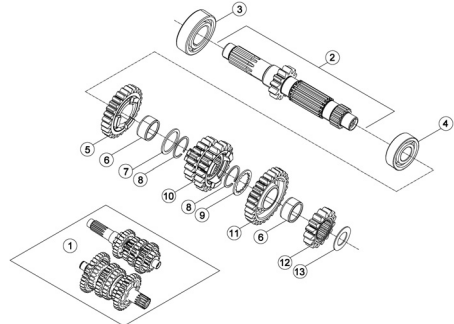

Pag. 14

TAV.04B Albero secondario - Counter shaft - Arbre secondaire - Nebentriebewelle - Eje secundario

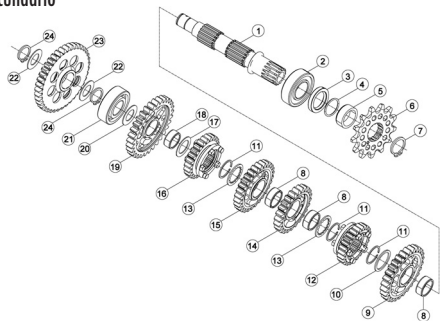

Pag. 15

TAV.05 Comando cambio - Gear shift control - Commande changement de vitesse - Chaltung - Mando cambio

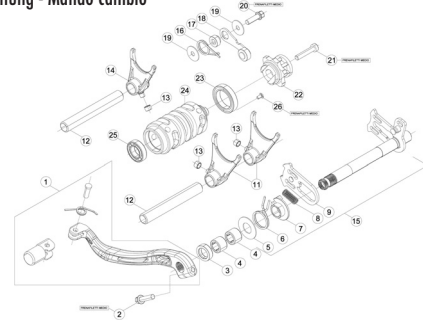

Pag. 16

TAV.06 Avviamento a pedale - Kickstarter - Dé marrage à pedal - Pedalstart - Arranque a pedal

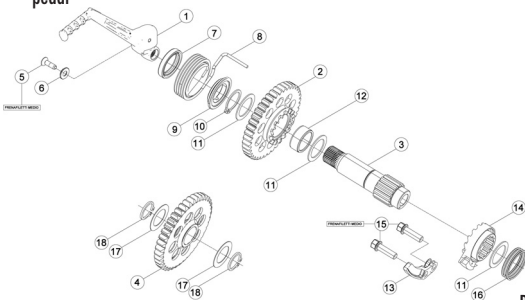

Pag. 17

TAV.07 Avviamento elettrico - Electric starter - Dé marrage électrique - Elektrischer start - Arranque eléctrico

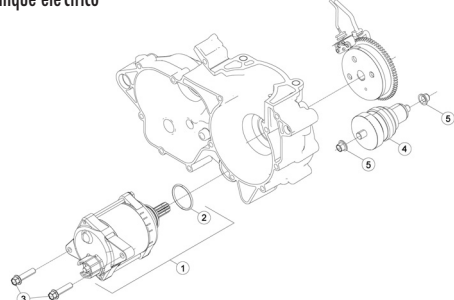

Pag. 18

TAV.09 Sistema di raffreddamento - Cooling system - Dispositifs de refroidissement - Kühlungssystem - Sistema de enfriamiento

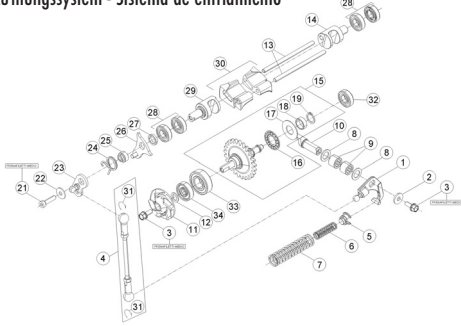

Pag. 20

TAV.10 Gruppo accensione elettronica - Electronic ignition assy. - Groupe allumage électronique - Elektronischezündgruppe - Grupo encendido electrónico

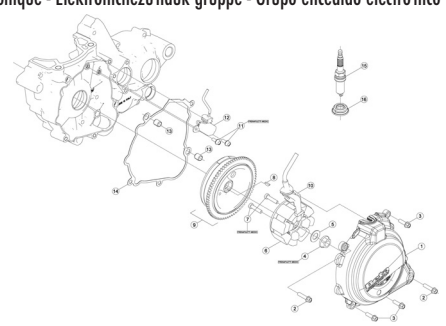

Pag. 22

TAV.11 Cilindro completo - Cylinder, assy - Cylindre complet - Zylinder, KPL. - Cilindro completo

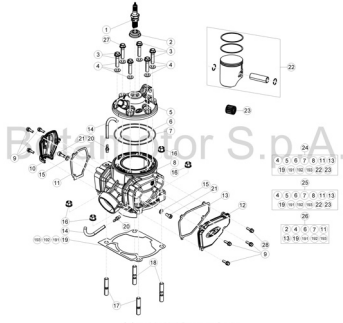

Pag. 24

TAV.12 Carburatore - Carburettor - Carburateur - Vergaser - Carburador

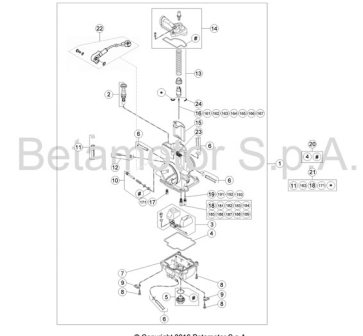

Pag. 26

TAV.14 Attrezzatura specifica - Special tools - Outillage spéciale - Spezialwerkzeug - Utillaje específico

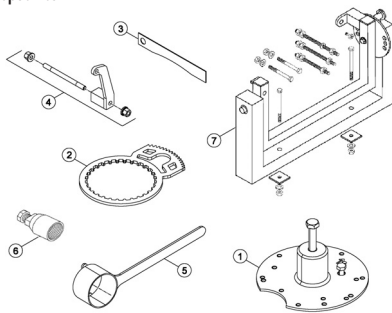

Pag. 28

TAV.31 Telaio - Frame - Chassis - Rahmen - Chasis

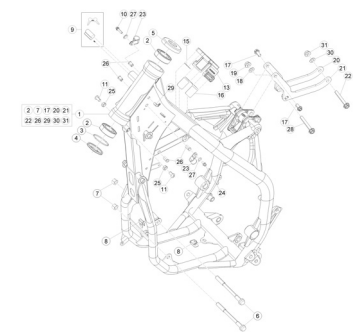

Pag. 30

TAV.32 Accessori telaio - Frame accessories - Accessoires chassis - Rahmenzubehör - Accesorios Chasis

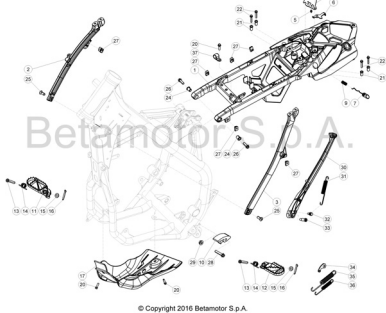

Pag. 32

TAV.33A Ammortizzatore posteriore - Rear damper - Amortisseur arrière - Hinterer Stoßdämpfer - Amortiguador posterior

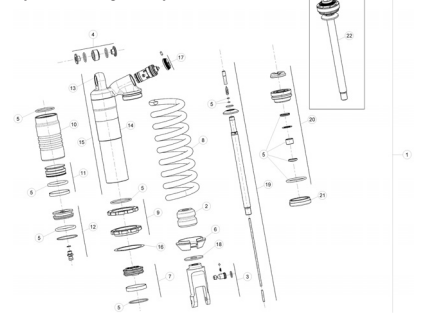

Pag. 34

TAV.33B Forcellone posteriore - Rear fork - Fourche arrière - Hinterradschwinge - Horquilla posterior

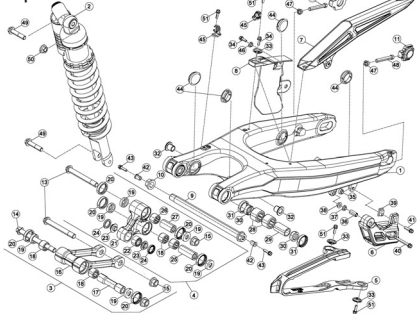

Pag. 36

TAV.34 Forcella anteriore - Front fork - Fourche AV. - Vorderradgabel - Horquilla delantera

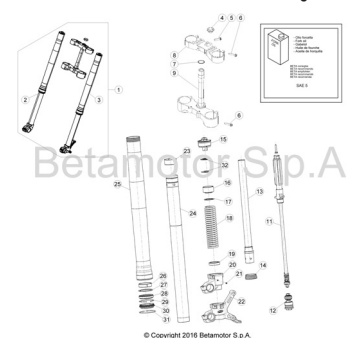

Pag. 38

TAV.35 Comandi-Manubrio - Controls-Handlebars - Commandes-Guidon - Bedienungselemente-Lenker - Mandos-Manillar

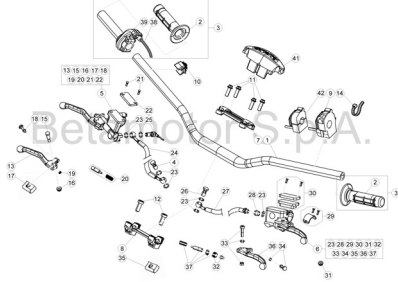

Pag. 40

TAV.36 Impianto freni idraulici - Hydraulic brakes system - Installation des freins hydrauliques - Hidraulischebremse anlage - Instalaci3n freno hidr3ulico

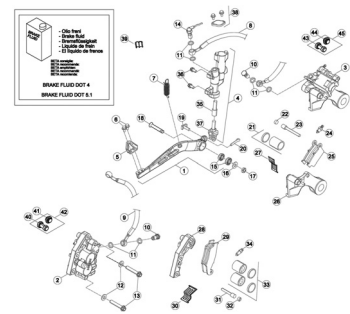

Pag. 42

TAV.37 Gruppo scarico - Exhaust system - Echappement - Auspuffanlage - Grupo escape

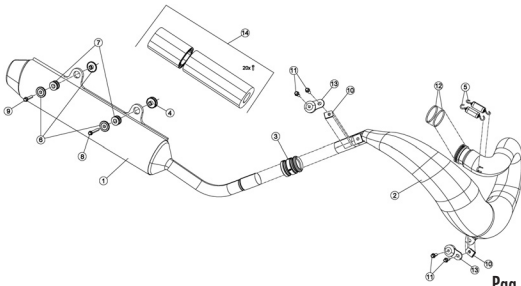

Pag. 43

TAV.38 Scatola filtro - Filter box - Boî tier du filtre - Sicherungskasten - Caja del filtro

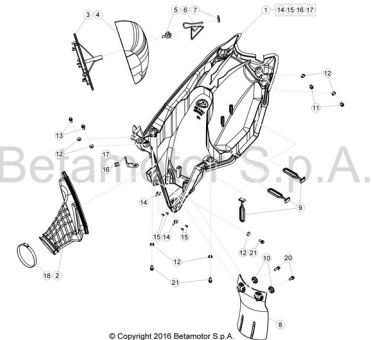

Pag. 44

TAV.39 Impianto di raffreddamento - Installation de refroidissement - Installation de refroidissement - Kühlsystem - Instalaci3n de enfriamiento

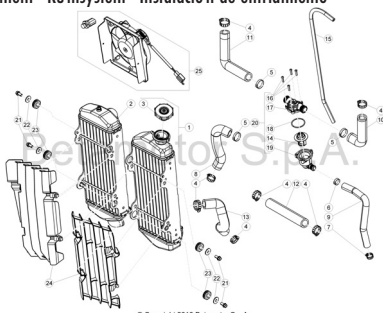

Pag. 46

TAV.40 Impianto elettrico - Electrical equipment - Installation électrique - Elektrische anlage - Instalaci3n electrica

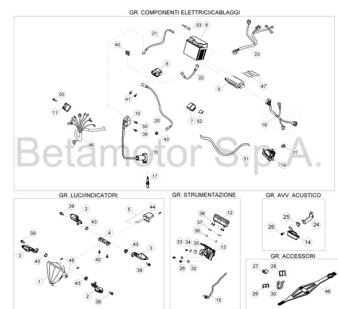

Pag. 48

TAV.41 Ruota anteriore - Front wheel - Roue AV. - Vorderrad - Rueda delantera

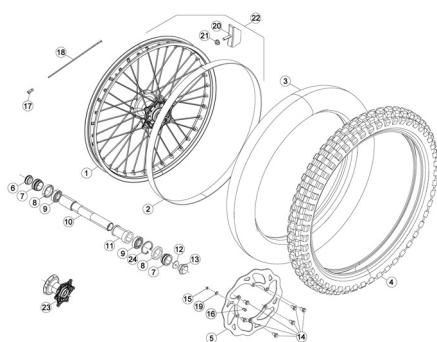

Pag. 50

TAV.42 Ruota posteriore - Rear wheel - Roue AR. - Hinterrad - Rueda trasera

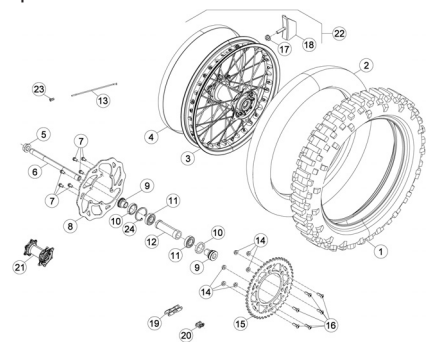

Pag. 51

TAV.43A Carenature-Parafanghi - Mudguards - Carenages-Gardeboues - Verkleidungen-Koffiü geln - Carenados-Guardabarros

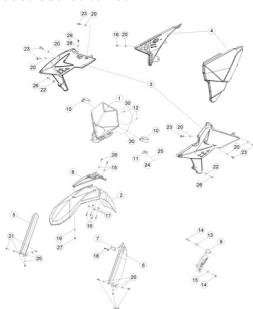

Pag. 52

TAV.43B Carenature-Serbatoio-Sella - Fairings-Tank-Saddle - Carenages-Reservoir-Selle - Verkleidungen-Tank-Sattel - Carenados-Deposito-Sill3n

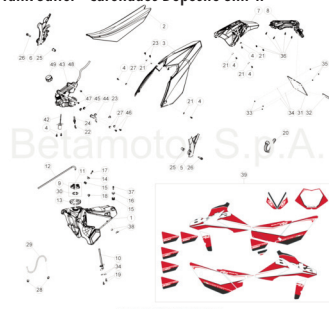

Pag. 54



TAV.44 Attrezzatura specifica - Special tools - Outillage spéciale - Spezialwerkzeug -  
Utilaje específico



Betamotor S.p.A.



© Copyright 2016 Betamotor S.p.A.

Pag. 56

# Tav.01A

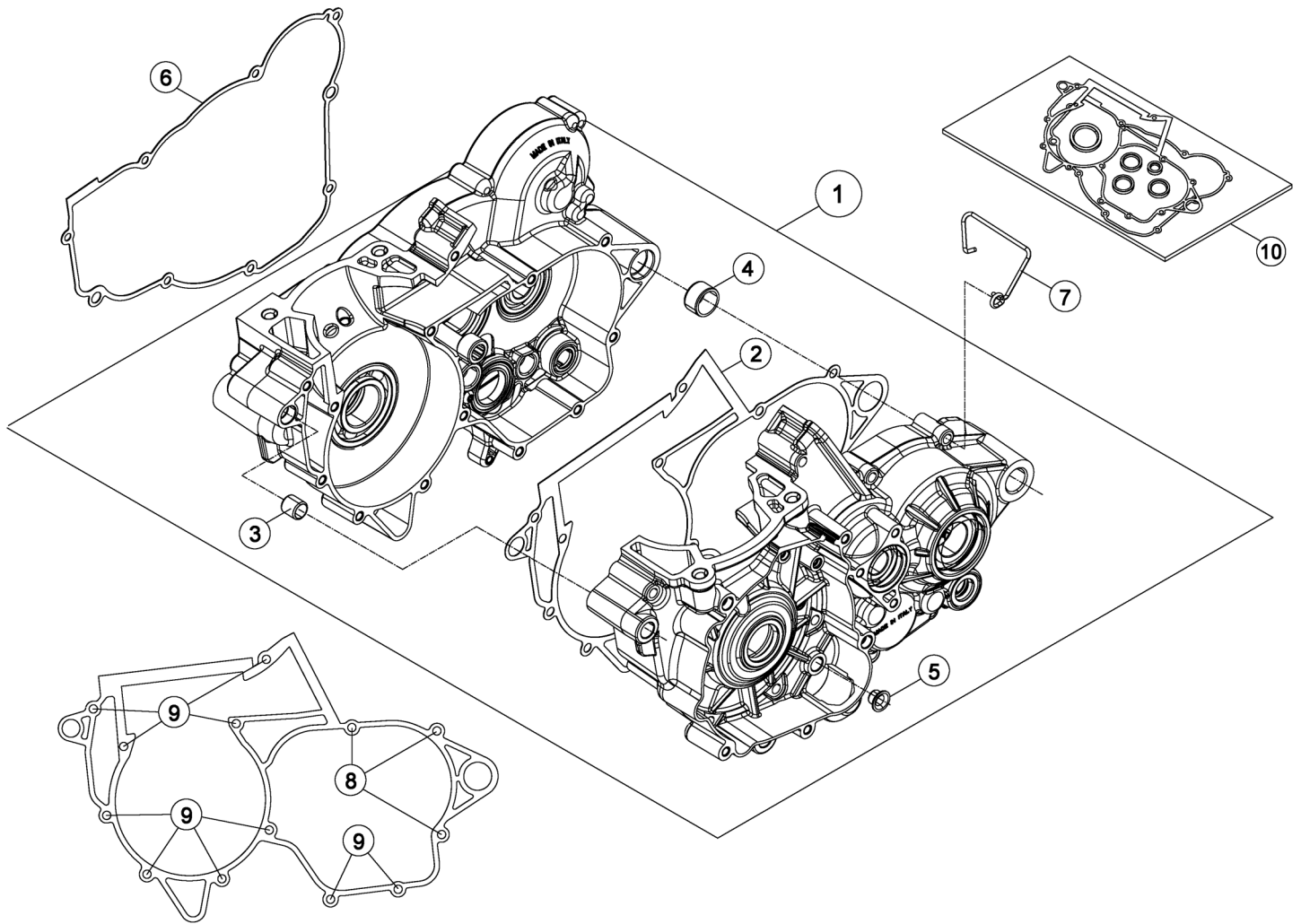

# Tav.01A

Pos Loc Pos Ps Pos	Numero Number Numéro Número Nummer	Q.tà Q.ty Q.té M.ge C.ad	Nota Note Note Nota Anm.	Descrizione	Description	Désignation	Beschreibung	Descripcìon
1	026.01.000.80.00	1		Carter motore	Crankcase assy	Carter moteur complet	Kurbelgehäuse, kompl.	Carter motor completo
2	026.01.003.00.00	1		Guarnizione carter	Crankcase gasket	Joint carter	Dichtung Kurbelwellengehäuse	Junta cárter
3	16.41500.000	1		Grano di riferimento	Dowel	Repère	Passtift	Centraje
4	006.01.012.00.00	1		Grano di riferimento 17x21.12	Dowel 17x21.12	Repère 17x21.12	Passtift 17x21.12	Centraje 17x21.12
5	C03.02.001.00.00	1		Boccola 8x10x8	Bush 8x10x8	Moyeu 8x10x8	Büchse 8x10x8	Buje 8x10x8
6	026.01.005.00.00	1		Guarnizione coperchio frizione	Clutch cover gasket	Joint couvercle embrayage	Dichtung Kupplungabdeckung	Junta tapa embrague
7	006.01.023.00.00	1		Passacavo	Grommet	Passe-câble	Kabeldurchgang	Pasacables
8	11.50360.000	3		Bullone M6x40	Bolt M6x40	Boulon M6x40	Bolzen M6x40	Tornillo M6x40
9	11.05535.000	10		Bullone 6.50 rs ch 8	Bolt 6.50 rs ch 8	Boulon 6.50 rs ch 8	Bolzen 6.50 rs ch 8	Tornillo 6.50 rs ch 8
10	026.01.012.82.00	1		Kit guarnizioni	Packings kit	Jeu joints	Dichtungensatz	Grupo juntas

# Tav.01B

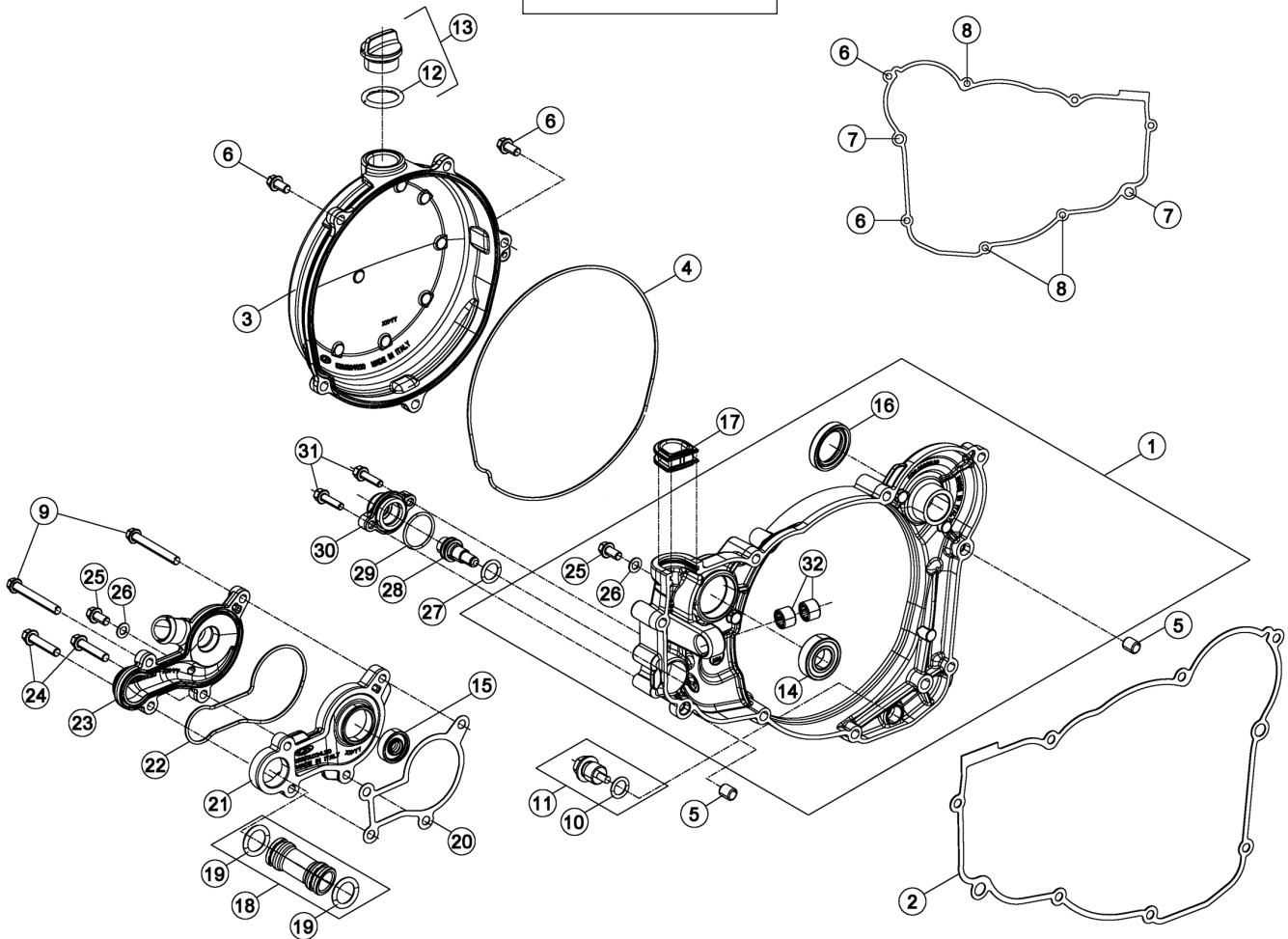

Pos	Numero	Q.tà	Nota	Descrizione	Description	Dé signation	Beschreibung	Descripció n
Loc	Number	Q.ty	Note					
Pos	Numé ro	Q.té	Note					
Ps	Nú mero	M.ge	Nota					
Pos	Nummer	C.ad	Anm.					
1	026.01.030.80.52	1		Coperchio frizione interno	Inner clutch cover	Couvercle interne d'embrayage	Innerer Kupplungsdeckel	Tapa interior embrague
2	026.01.005.00.00	1		Guarnizione coperchio frizione	Clutch cover gasket	Joint couvercle embrayage	Dichtung Kupplungsabdeckung	Junta tapa embrague
3	026.01.040.80.52	1		Coperchio frizione esterno	Outer clutch cover	Couvercle externe d'embrayage	Äußerer Kupplungsdeckel	Tapa exterior embrague
4	026.01.041.00.00	1		Guarnizione coperchio frizione	Clutch cover gasket	Joint couvercle embrayage	Dichtung Kupplungsabdeckung	Junta tapa embrague
5	16.36500.000	2		Grano 9x7,2x10	Dowel 9x7,2x10	Goujon 9x7,2x10	Stift 9x7,2x10	Clavija 9x7,2x10
6	11.49070.000	4		Bullone 6x20 ch rs	Bolt 6x20 ch rs	Boulon 6x20 ch rs	Bolzen 6x20 ch rs	Tornillo 6x20 ch rs
7	11.50300.000	2		Bullone 6x30 ch rs	Bolt 6x30 ch rs	Boulon 6x30 ch rs	Bolzen 6x30 ch rs	Tornillo 6x30 ch rs
8	11.05535.000	3		Bullone 6.50 rs ch 8	Bolt 6.50 rs ch 8	Boulon 6.50 rs ch 8	Bolzen 6.50 rs ch 8	Tornillo 6.50 rs ch 8
9	11.05485.000	2		Bullone M6x60 rs ch 8	Bolt M6x60 rs ch 8	Boulon M6x60 rs ch 8	Bolzen M6x60 rs ch 8	Tornillo M6x60 rs ch 8
10	10.66164.000	1		Anello Or 11x2,5 nbr70 sh	O-Ring 11x2,5 nbr70 sh	Bague d' é tanché ité 11x2,5	O-Ring 11x2,5 nbr70 sh	Anillo Or 11x2,5 nbr70 sh
11	006.08.152.80.00	1		Tappo scarico olio	Oil exh. plug	Bouchon dech. huile	Öelablassschraube	Tapó n de descarge aceite
12	10.66340.000	1		Anello OR 16x3	O-Ring 16x3	Bague d' é tanché ité 16x3	O-Ring 16x3	Anillo OR 16x3
13	026.01.013.80.00	1		Tappo completo	Complete cap	Bouchon complet	Verschluß komplett	Tapó n completo
14	006.01.001.00.00	1		Cuscinetto 15.32.9 6002-2RSH C3	Bearing 15.32.9 6002-2RSH C3	Roulement 15.32.9 6002-2RSH C3	Lager 15.32.9 6002-2RSH C3	Cojinete 15.32.9 6002-2RSH C3
15	10.43720.000	1		Anello paraolio 8.24.7	Oil seal 8.24.7	Joint d' é tanché ité 8.24.7	Ölschutzring 8.24.7	Reté n de aceite 8.24.7
16	10.64490.000	1		Anello paraolio 20x30.5/6	Oil seal 20x30.5/6	Joint d' é tanché ité 20x30.5/6	Ölschutzring 20x30.5/6	Reté n de aceite 20x30.5/6
17	026.01.031.80.00	1		Guarnizione asta valvola	Valve stem seal	Joint d' etanch. de tige de soupape	Ventilshaftdichtung	Sello de vastago de valvula
18	026.01.037.80.00	1		Tubo acqua	Water pipe	Tuyau de l' eau	Kü hflü ssigkeitsleitung	Tubo agua
19	026.06.052.00.00	2		Anello OR 17,96x2,62	O-Ring 17,96x2,62	Bague d' é tanché ité 17,96x2,62	O-Ring 17,96x2,62	Anillo OR 17,96x2,62
20	026.01.036.00.00	1		Guarnizione pompa acqua	Water pump gasket	Joint pompe eau	Dichtung Wasserpumpe	Empaque bomba agua
21	026.01.034.00.00	1		Corpo pompa acqua	Water pump plunger cylinder	Cylindre de plongeur pompe eau	Wasserpumpengehä use	Cuepo bomba agua
22	026.01.035.00.00	1		Guarnizione pompa acqua	Water pump gasket	Joint pompe eau	Dichtung Wasserpumpe	Empaque bomba agua
23	026.01.033.00.00	1		Coperchio pompa acqua	Water pump cover	Couvercle pompe à eau	Wasserpumpendeckel	Tapa bomba agua
24	11.50300.000	2		Bullone 6x30 ch rs	Bolt 6x30 ch rs	Boulon 6x30 ch rs	Bolzen 6x30 ch rs	Tornillo 6x30 ch rs
25	11.47015.000	2		Bullone M6x12	Bolt M6x12	Boulon M6x12	Bolzen M6x12	Tornillo M6x12
26	27.40495.000	2		Rondella in rame 6.11	Copper washer 6.11	Rondelle en cuivre 6.11	Kupfer U.Scheibe 6.11	Arandela de cobre 6.11
27	10.66296.000	1		Anello OR 12,37,2,62	O-Ring 12,37,2,62	Bague d' é tanché ité 12,37,2,62	O-Ring 12,37,2,62	Anillo OR 12,37,2,62
28	026.09.020.00.00	1		Guida molla	Spring guide	Guide ressort	Federfuehrung	Guiá de resorte
29	10.66540.000	1		Anello OR 24.2	O-Ring 24.2	Bague d' é tanché ité 24.2	O-Ring 24.2	Anillo OR 24.2
30	026.09.025.00.00	1		Coperchio	Cover	Couvercle	Deckel	Tapa
31	11.46401.000	2		Bullone M5x20	Bolt M5x20	Boulon M5x20	Bolzen M5x20	Tornillo M5x20
32	11.22100.000	2		Boccola a rulli 10.14.10	Roller bearing 10.14.10	Douille à roulements	Rollenbuchse	Caja de grasa de rodillos



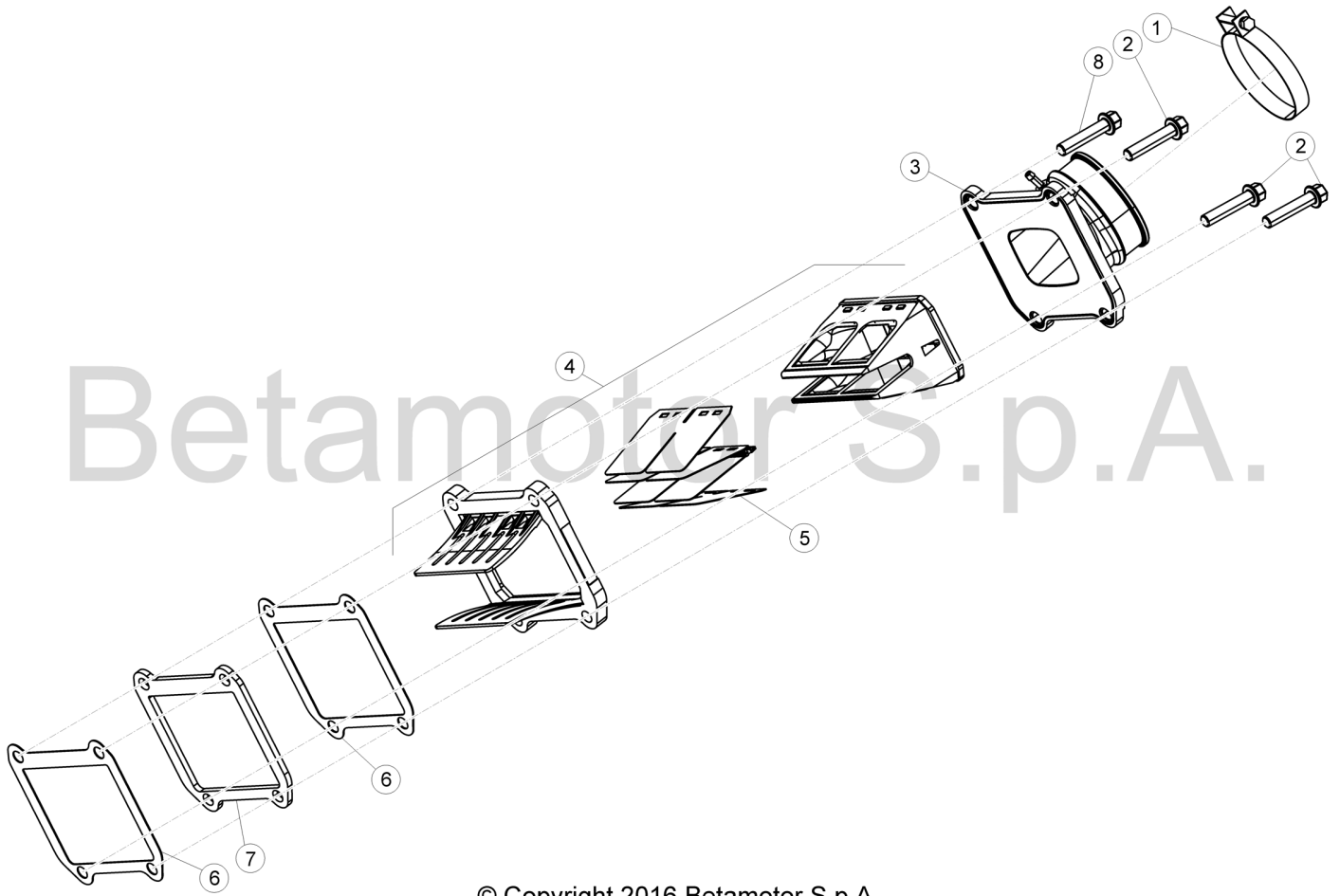

© Copyright 2016 Betamotor S.p.A.

Pos Loc Pos Ps Pos	Numero Number Numéro Número Nummer	Q.tà Q.ty Q.té M.ge C.ad	Nota Note Note Nota Anm.	Descrizione	Description	Dé signation	Beschreibung	Descripció n
1	15.14275.000	1		Fascetta 52/12	Clamp 52/12	Collier 52/12	Schelle 52/12	Abrazadera 52/12
2	11.50300.000	3	250cc	Bullone 6x30 ch rs	Bolt 6x30 ch rs	Boulon 6x30 ch rs	Bolzen 6x30 ch rs	Tornillo 6x30 ch rs
2	11.50010.000	3	300cc	Bullone M6x25	Bolt M6x25	Boulon M6x25	Bolzen M6x25	Tornillo M6x25
3	036.01.005.80.00	1		Collettore di aspirazione	Inlet duct	Conduit adm.	Ansaugstutzen	Colector
4	026.01.007.80.00	1		Pacco lamellare	Leaf valve	Pyramide clapets	Lamellenpaket	Válvula lá minas
5	026.01.009.00.00	1		Kit lamelle	Plate kit	Kit lamelle	Plättchenkit	Kit Laminilla
6	026.01.010.00.00	2	250cc	Guarnizione valvola aspirazione	Suction valve gasket	Joint soupape aspir.	Dichtung Einlaßventil	Junta válvula aspiració n
6	026.01.010.00.00	1	300cc	Guarnizione valvola aspirazione	Suction valve gasket	Joint soupape aspir.	Dichtung Einlaßventil	Junta válvula aspiració n
7	026.01.008.42.52	1	250cc	Distanziale	Spacer	Entretroise	Distanzstück	Distanciador
8	026.11.034.00.00	1	250cc	Vite di sicurezza	Tab screw	Vis de sûreté	Sicherungs-Schraube	Tornillo de seguridad
8	026.11.035.00.00	1	300cc	Vite di sicurezza	Tab screw	Vis de sûreté	Sicherungs-Schraube	Tornillo de seguridad

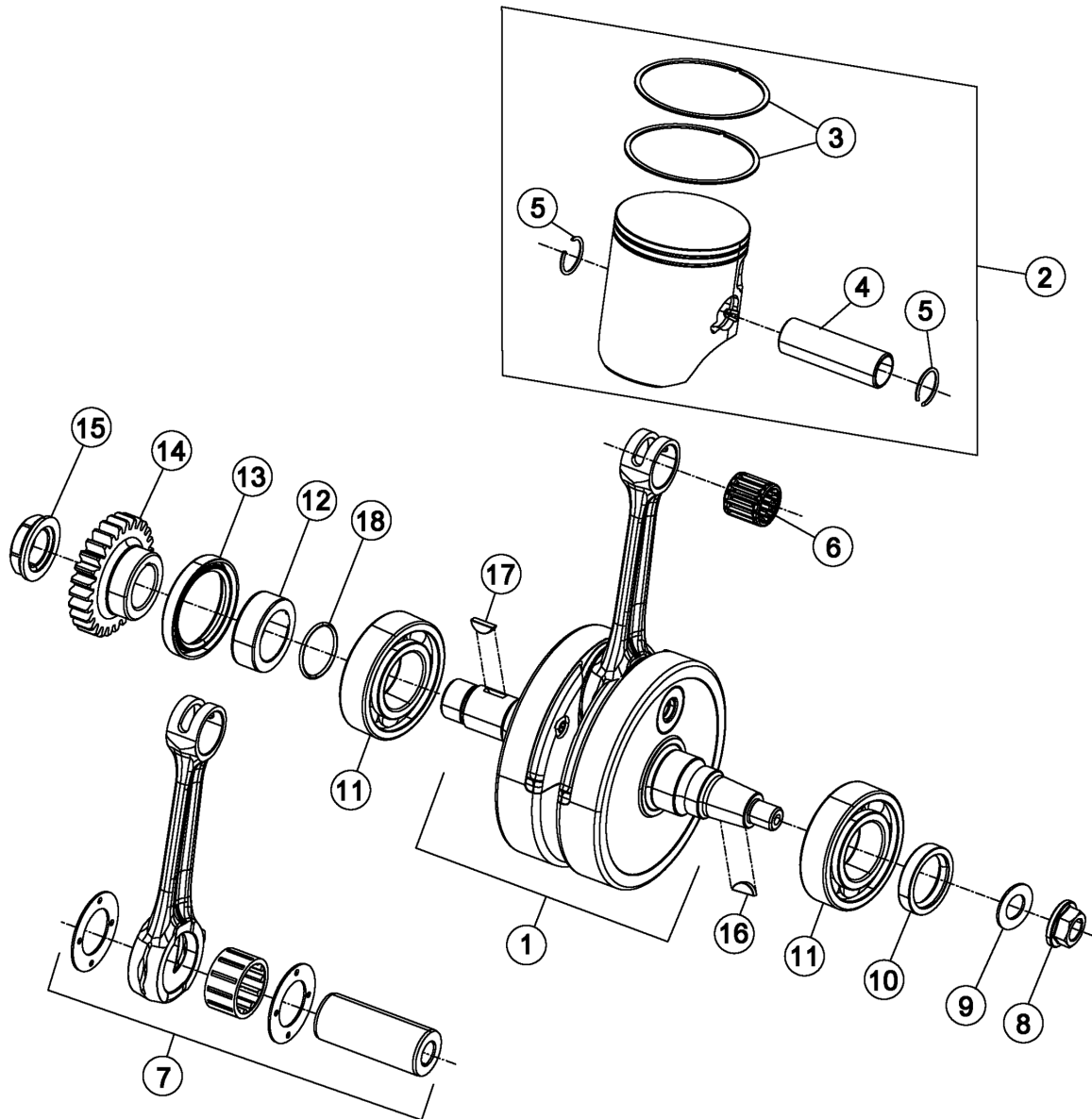

# Tav.02

Pos Loc Pos Ps Pos	Numero Number Numé ro Número Nummer	Q.tà Q.ty Q.té M.ge C.ad	Nota Note Note Nota Anm.	Descrizione	Description	Dé signation	Beschreibung	Descrìpiò n
1	026.02.000.80.00	1		Albero motore completo	Crankshaft, assy.	Arbre moteur complet	kurbelwelle, komplett	Cigü eñ al completo
2	026.02.024.80.0A	1	250cc	Pistone completo 250cc - Sel. A	Piston set 250cc - Sel. A	Piston compl. 250cc - Sé l. A	Kolben, kompl. 250cc - Auswahl A	Pistó n, compl. 250cc - Sel. A
2	026.02.024.80.0B	1	250cc	Pistone completo 250cc - Sel. B	Piston set 250cc - Sel. B	Piston compl. 250cc - Sé l. B	Kolben, kompl. 250cc - Auswahl B	Pistó n, compl. 250cc - Sel. B
2	026.02.024.80.0C	1	250cc	Pistone completo 250cc - Sel. C	Piston set 250cc - Sel. C	Piston compl. 250cc - Sé l. C	Kolben, kompl. 250cc - Auswahl C	Pistó n, compl. 250cc - Sel. C
2	026.02.032.80.0A	1	300cc	Pistone completo 300cc - Sel. A	Piston set 300cc - Sel. A	Piston compl. 300cc - Sé l. A	Kolben, kompl. 300cc - Auswahl A	Pistó n, compl. 300cc - Sel. A
2	026.02.032.80.0B	1	300cc	Pistone completo 300cc - Sel. B	Piston set 300cc - Sel. B	Piston compl. 300cc - Sé l. B	Kolben, kompl. 300cc - Auswahl B	Pistó n, compl. 300cc - Sel. B
2	026.02.032.80.0C	1	300cc	Pistone completo 300cc - Sel. C	Piston set 300cc - Sel. C	Piston compl. 300cc - Sé l. C	Kolben, kompl. 300cc - Auswahl C	Pistó n, compl. 300cc - Sel. C
3	026.02.025.00.00	2	250cc	Segmento pistone 250cc	Piston ring 250cc	Segment de piston 250cc	Kolbendichtring 250cc	Aro piston 250cc
3	026.02.031.00.00	2	300cc	Segmento pistone 300cc	Piston ring 300cc	Segment de piston 300cc	Kolbendichtring 300cc	Aro piston 300cc
4	026.02.023.00.00	1		Spinotto	Pin	Axe	Zapfen	Eje
5	10.42600.000	2		Anello ferma spinotto	Piston pin lock ring	Bague de serrage goujon	Bolzenfeststellring	Anillo sujeta pasador
6	16.16710.000	1		Gabbia	Cage	Cage	Lagerkä fig	Jaula
7	026.02.004.80.00	1		Biella completa	Conn.-rod, assy	Bielle compl.	Pleuel, kompl.	Biela compl.
8	13.25010.000	1		Dado M12x1	Nut M12x1	Ecrou M12x1	Mutter M12x1	Tuerca M12x1
9	27.74810.000	1		Rondella elastica	Spring Washer	Rondelle é lastique	Federring	Arandela elá stica
10	C02.01.041.00.00	1		Anello di tenuta 25.35.7	Oil seal 25.35.7	Joint d' é tanché ité 25.35.7	Ölschutzring 25.35.7	Reté n de aceite 25.35.7
11	C06.01.035.00.00	2		Cuscinetto	Bearing	Roulement	Lager	Cojinete
12	026.02.009.00.00	1		Distanziale	Spacer	Entretoise	Distanzstü ck	Distanciador
13	C02.01.001.00.00	1		Anello paraolio 38.52.7	Oil seal 38.52.7	Joint d' é tanché ité 38.52.7	Ölschutzring 38.52.7	Reté n de aceite 38.52.7
14	026.03.012.00.00	1		Pignone trasmissione primaria	Main Drive Sprocket	Pignon Transmission Primaire	Primä raantriebsritzel	Piñ ó n Transmisión Primaria
15	006.03.023.00.00	1		Dado M20X1x5 LH	Nut M20X1x5 LH	Ecrou M20X1x5 LH	Mutter M20X1x5 LH	Tuerca M20X1x5 LH
16	12.46020.000	1		Chiavetta 3x5	Key 3x5	Clavette 3x5	Keil 3x5	Chaveta 3x5
17	12.46151.000	1		Linguetta 4x5 uni 6606	Plate 4x5 uni 6606	Plaquette 4x5 uni 6606	Plättchen 4x5 uni 6606	Lengü eta 4x5 uni 6606
18	10.66620.000	1		Anello or 25,12x1,78	O-Ring 25,12x1,78	Bague d' é tanché ité 25,12x1,78	O-Ring 25,12x1,78	Anillo OR 25,12x1,78

# Tav.03

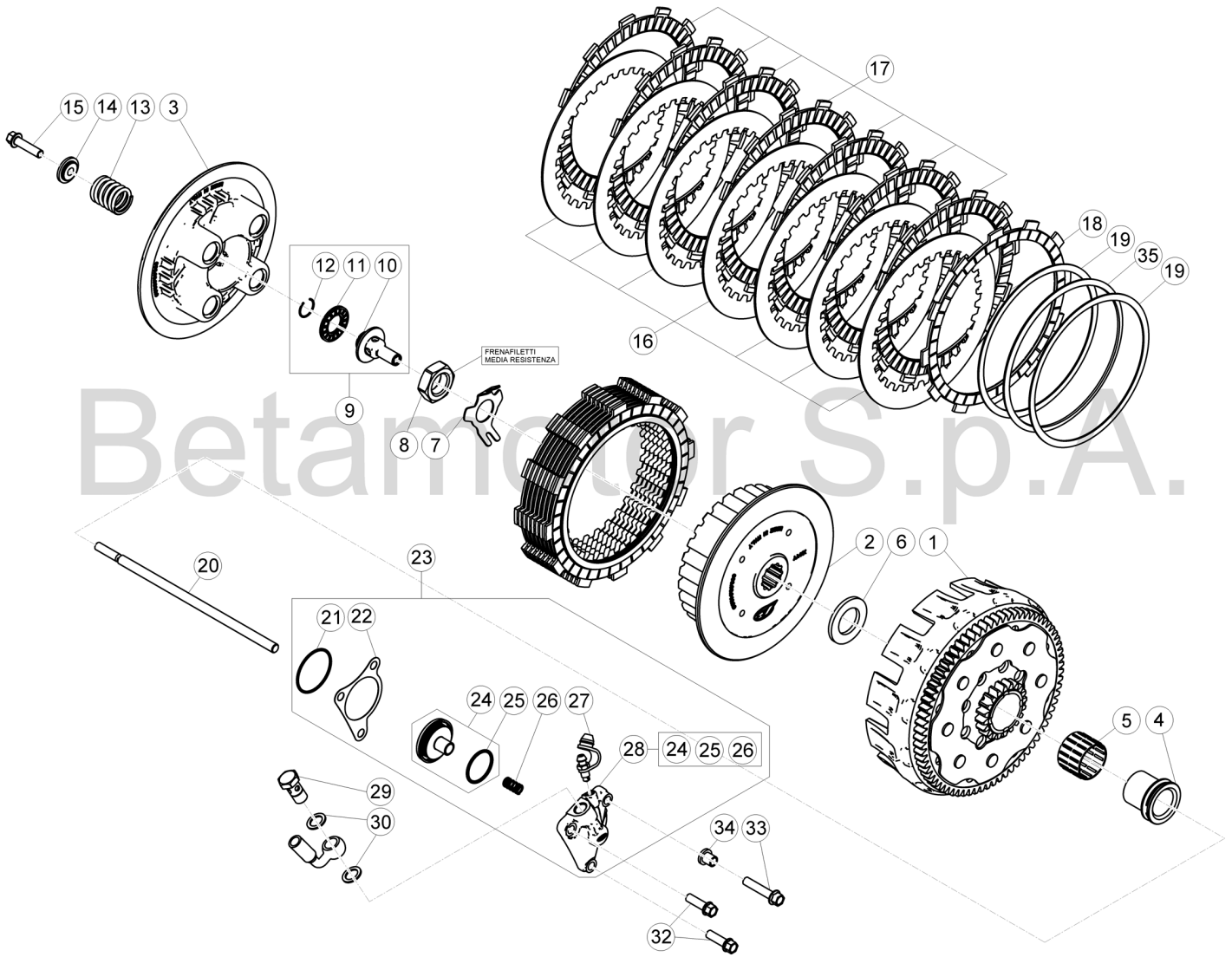

© Copyright 2016 Betamotor S.p.A.



# Tav.03

Pos Loc Pos Ps Pos	Numero Number Numéro Nummer	Q.tà Q.ty Q.té M.ge C.ad	Nota Note Nota Anm.	Descrizione	Description	Dé signation	Beschreibung	Descrìpziò n
1	026.03.013.80.00	1		Campana frizione compl.	Clutch case assembly	Cloche d' embayage compl.	Kupplungsglocke.	Campana de embr.completa
2	006.03.140.00.00	1		Tamburo frizione	Clutch drum	Tambour d' embr.	Kupplungsstrommel	Tambor de embr.
3	006.03.030.00.00	1		Piattello spingidisco	Spring collar	Godet d' embayage	Druckteller	Platillo embrague
4	026.03.061.00.00	1		Boccola	Bush	Moyeu	Büchse	Buje
5	006.03.063.00.00	1		Boccola a rulli 26x30.22	Roller bearing 26x30.22	Douille à roulements 26x30.22	Rollenbuchse 26x30.22	Caja de grasa de rodillos 26x30.22
6	006.03.062.00.00	1		Rondella 21,7x38.3.	Washer 21,7x38.3.	Rondelle 21,7x38.3.	U.Scheibe 21,7x38.3.	Arandela 21,7x38.3.
7	006.03.064.00.09	1		Rondella di sicurezza	Tab washer	Rondelle de sûreté	Sicherungs-Unterlegscheibe	Arandela de seguridad
8	006.03.065.00.00	1		Dado M18x1,5 h9	Nut M18x1,5 h9	Ecrou M18x1,5 h9	Mutter M18x1,5 h9	Tuerca M18x1,5 h9
9	006.03.071.80.00	1		Innesto Asta Corpo Frizione comp.	Clutch Housing Rod Coupling, assy	Crabot Tige Corps Embrayage compl.	Stabeinkupplung Kupplungskörper, kpl.	Acople Varilla Cuerpo Embrague comp.
10	006.03.071.00.00	1		Innesto Asta Corpo Frizione	Clutch Housing Rod Coupling	Crabot Tige Corps Embrayage	Stabeinkupplung Kupplungskörper	Acople Varilla Cuerpo Embrague
11	16.11370.000	1		Gabbia reggispinga 15x28x2 con 1AS	Thrust bearing cage 15x28x2 with 1AS	Buté e à aiguilles 15x28x2 avec 1AS	Andruckkäfig 15x28x2 mit 1AS	Jaula cojinete de empuje 15x28x2 con 1AS
12	28.23105.000	1		Seeger RB14 DIN 7993	Circlip RB14 DIN 7993	Circlip RB14 DIN 7993	Seeger RB14 DIN 7993	Seeger RB14 DIN 7993
13	022.03.055.00.00	4		Molla frizione	Clutch spring	Ressort embr.	Kupplg.feder	Muelle embr.
14	006.03.156.00.00	4		Reggimolla Frizione	Spring Retainer	Porte-Ressort Embrayage	Federteller	Portamuelle Embrague
15	11.50010.000	4		Bullone M6x25	Bolt M6x25	Boulon M6x25	Bolzen M6x25	Tornillo M6x25
16	006.03.050.00.00	7		Disco acciaio	Steel plate	Disque lisse	Stahlscheibe	Disco
17	006.03.052.00.00	7		Disco frizione	Clutch disk	Disque embr.	Kupplungs-scheib	Disco de embrague
18	006.03.153.00.00	1		Disco frizione	Clutch disk	Disque embr.	Kupplungs-scheib	Disco de embrague
19	006.03.057.00.00	2		Rondella	Washer	Rondelle	U.Scheibe	Arandela
20	026.03.070.00.00	1		Astina frizione	Clutch fl. dipstick	Axe embrayage	Kupplungsstange	Varita embrague
21	10.66840.000	1		Anello OR 33x1,5	O-Ring 33x1,5	Bague d' é tanché ité 33x1,5	O-Ring 33x1,5	Anillo OR 33x1,5
22	006.03.085.00.00	1		Guarnizione frizione	Clutch lining	Garniture embrayage	Kupplungsbelag	Forro de embrague
23	006.03.180.80.00	1		Corpo attuatore completo	Actuator body, assy.	Corps actionneur complet	Gehäuse Stellantrieb kpl.	Cuerpo del actuador completo
24	006.03.081.80.00	1		Pistone	Piston	Piston	Kolben	Pistón
25	10.66520.000	1		Anello OR 23,52X1,78	O-Ring 23,52X1,78	Bague d' é tanché ité 23,52X1,78	O-Ring 23,52X1,78	Anillo OR 23,52X1,78
26	006.03.083.00.00	1		Molla	Spring	Ressort	Feder	Muelle
27	28.91050.000	1		Tappo sfciato	Breather plug	Bouchon reniflard	Verschluß Entlüfter	Tapón respiradero
28	006.03.080.80.00	1		Corpo attuatore	Actuator body	Corps actionneur	Gehäuse Stellantrieb	Cuerpo del actuador
29	11.65040.000	1		Bullone forato 10x1 x tubo freno	Special bolt	Boulon 10x1 x tube frein	Hohlschraube F.Bremse	Tornillo esp. talad.10.1
30	16.50510.000	2		Guarnizione 10x15x1 in rame	Gasket 10x15x1 copper	Joint 10x15x1 cuivre	Dichtung 10x15x1 Kupfer	Junta 10.15.1 (cobre)
32	11.49070.000	2		Bullone 6x20 ch rs	Bolt 6x20 ch rs	Boulon 6x20 ch rs	Bolzen 6x20 ch rs	Tornillo 6x20 ch rs
33	11.50300.000	1		Bullone 6x30 ch rs	Bolt 6x30 ch rs	Boulon 6x30 ch rs	Bolzen 6x30 ch rs	Tornillo 6x30 ch rs
34	13.49190.000	1		Distanziale 10mm	Spacer 10mm	Entretoise 10mm	Distanzstück 10mm	Distanciadador 10mm
35	006.03.158.00.00	1		Molla a tazza	Belleville spring	Ressort à godet	Tassenfeder	Muelle de taza

# Tav.04A

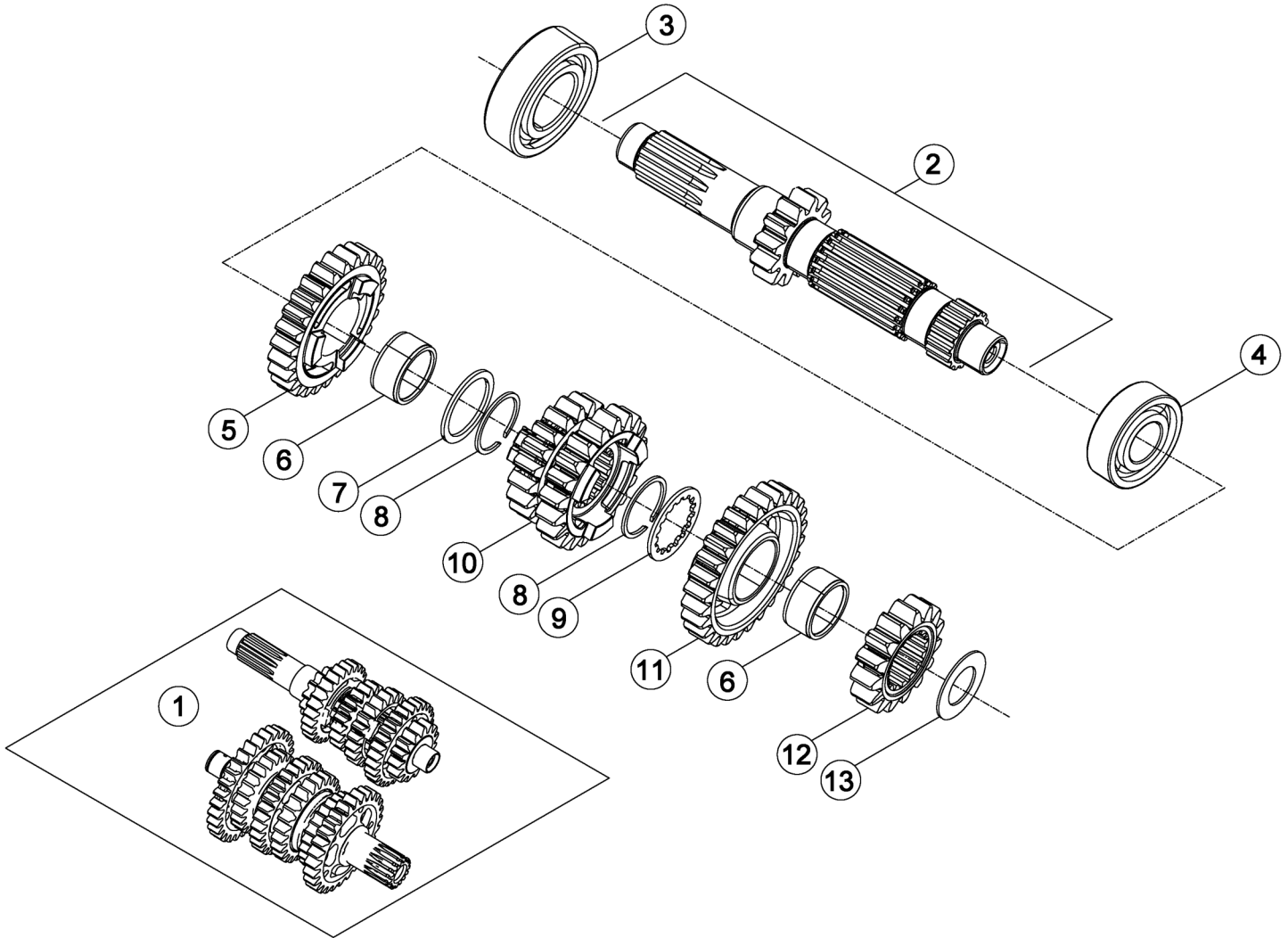

Pos Loc Pos Ps Pos	Numero Number Numéro Número Nummer	Q.tà Q.ty Q.té M.ge C.ad	Nota Note Note Nota Anm.	Descrizione	Description	Désignation	Beschreibung	Descripció
1	026.04.000.80.00	1		Cambio completo	Transmission, assy	Boî te de vitesses	Getriebe komplett	Cambio completo
2	026.04.010.00.00	1		Albero primario completo	Complete main shaft	Arbre primaire complet	Komplette Hauptwelle	Arbol primario completo
3	12.95610.000	1		Cuscinetto 6205	Bearing 6205	Roulement 6205	Lager 6205	Cojinete 6205
4	12.95605.000	1		Cuscinetto 6203	Bearing 6203	Roulement 6203	Lager 6203	Cojinete 6203
5	006.04.015.00.00	1		Quinta sul primario	Fifth gear - mainshaft	Cinquième sur le primaire	5. Gang auf antriebswelle	Quinta marcha en el cigüeñal primario
6	11.22855.000	2		Gabbia a rulli 22x26x13	Roller cage 22x26x13	Cage a roul. 22x26x13	Rollenkäfig 22x26x13	Jaula de rod. 22x26x13
7	006.04.031.00.00	1		Rondella rasamento	Thrust washer	Rondelle de butée	Anlaufscheibe	Arandela distanciadora
8	28.25520.000	2		Seeger 25 SW	Circlip 25 SW	Circlip 25 SW	Seeger 25 SW	Seeger 25 SW
9	006.04.030.00.00	1		Rondella rasamento	Thrust washer	Rondelle de butée	Anlaufscheibe	Arandela distanciadora
10	006.04.013.00.00	1		Terza e quarta sul primario	Third and fourth gear - mainshaft	Troisième et quatrième sur le primaire	3. Gang und 4. Gang auf antriebswelle	Tercera y Cuarta marcha en el cigüeñal primario
11	006.04.016.00.00	1		Sesta sul primario	6th gear - mainshaft	Sixième sur le primaire	6. Gang auf antriebswelle	Sexta marcha en el cigüeñal primario
12	006.04.012.00.00	1		Seconda sul primario	Second gear - mainshaft	Deuxième sur le primaire	2. Gang auf abtriebswelle	Segunda marcha en el cigüeñal primario
13	006.04.032.00.00	1		Rondella rasamento 17x30x1	Thrust washer 17x30x1	Rondelle de butée 17x30x1	Anlaufscheibe 17x30x1	Arandela distanciadora 17x30x1

# Tav.04B

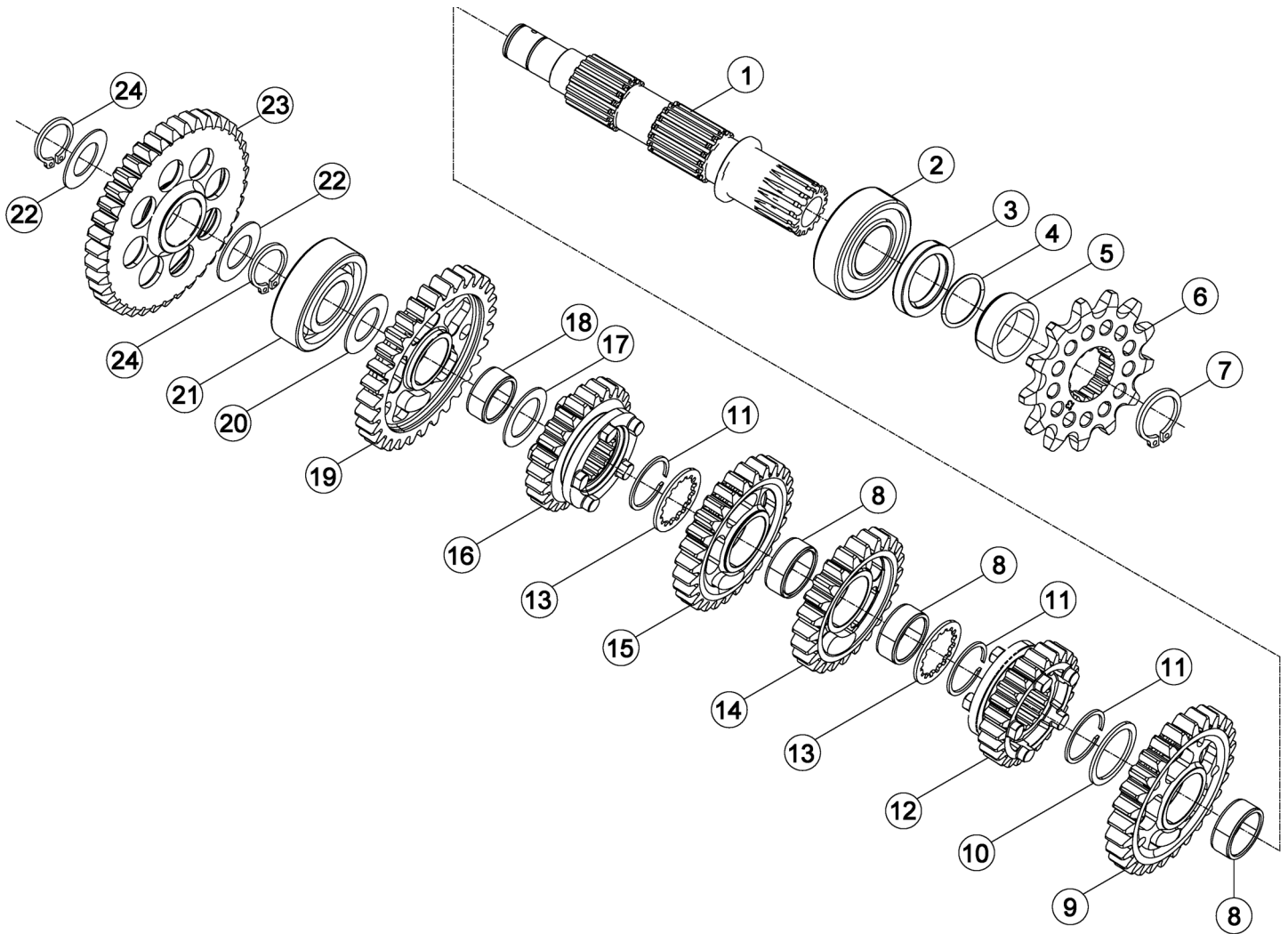

Pos	Numero	Q.tà	Nota	Descrizione	Description	Désignation	Beschreibung	Descripció
Loc	Number	Q.ty	Note					
Pos	Número	Q.té	Note					
Ps	Número	M.ge	Nota					
Pos	Nummer	C.ad	Anm.					
1	026.04.020.00.00	1		Albero secondario	Counter shaft	Arbre secondaire	Nebengeriebewelle	Eje secundario
2	12.99710.000	1		Cuscinetto NJ205	Bearing NJ205	Roulement NJ205	Lager NJ205	Cojinete NJ205
3	10.66020.000	1		Anello paraolio 32x45x6x5	Oil seal 32x45x6x5	Joint d' é tanché ité 32x45x6x5	Ölschutzring 32x45x6x5	Retén de aceite 32x45x6x5
4	10.66540.000	1		Anello OR 24.2	O-Ring 24.2	Bague d' é tanché ité 24.2	O-Ring 24.2	Anillo OR 24.2
5	006.04.040.00.00	1		Distanziale	Spacer	Entretoise	Distanzstück	Distanciadore
6	006.04.050.00.00	1		Pignone Z=13	Pinion Z=13	Pignon Z=13	Ritzel Z=13	Piñón Z=13
6	006.04.052.00.00	1		Pignone Z=15 omologazione	Pinion Z=15 homologation	Pignon Z=15 homologation	Ritzel Z=15 Zulassung	Piñón Z=15 homologación
7	28.25530.000	1		Anello seeger 25x2	Snap ring 25x2	Circlips 25x2	Seegerring 25x2	Anillo seeger 25x2
8	11.22845.000	3		Gabbia a rulli 22x26x10	Roller cage 22x26x10	Cage a roul. 22x26x10	Rollenkäfig 22x26x10	Jaula de rod. 22x26x10
9	006.04.022.00.00	1		Seconda sul secondario	Second gear - layshaft	Deuxième sur le secondaire	2. Gang auf Vorgelegewelle	Segunda marcha en el cigüeñal sec.
10	006.04.031.00.00	1		Rondella rasamento	Thrust washer	Rondelle de butée	Anlaufscheibe	Arandela distanciadora
11	28.25520.000	3		Seeger 25 SW	Circlip 25 SW	Circlip 25 SW	Seeger 25 SW	Seeger 25 SW
12	006.04.026.00.00	1		Sesta sul secondario	6th gear - layshaft	Sixième sur le secondaire	6. Gang auf Vorgelegewelle	Sexta marcha en el cigüeñal sec.
13	006.04.030.00.00	2		Rondella rasamento	Thrust washer	Rondelle de butée	Anlaufscheibe	Arandela distanciadora
14	006.04.024.00.00	1		Quarta sul secondario	Fourth gear - layshaft	Quatrième sur le secondaire	4. Gang auf Vorgelegewelle	Cuarta marcha en el cigüeñal sec.
15	006.04.023.00.00	1		Terza sul secondario	Third gear - layshaft	Troisième sur le secondaire	3. Gang auf Vorgelegewelle	Tercera marcha en el cigüeñal sec.
16	006.04.025.00.00	1		Quinta sul secondario	Fifth gear - layshaft	Cinquième sur le secondaire	5. Gang auf Vorgelegewelle	Quinta marcha en el cigüeñal sec.
17	006.04.033.00.00	1		Rondella rasamento 20x30x1	Thrust washer 20x30x1	Rondelle de butée 20x30x1	Anlaufscheibe 20x30x1	Arandela distanciadora 20x30x1
18	11.22835.000	1		Gabbia a rulli 20x24x10	Roller cage 20x24x10	Cage a roul. 20x24x10	Rollenkäfig 20x24x10	Jaula de rod. 20x24x10
19	006.04.021.00.00	1		Prima sul secondario	First gear - layshaft	Première sur le secondaire	1. Gang auf Vorgelegewelle	Primera marcha en el cigüeñal secundario
20	006.04.032.00.00	1		Rondella rasamento 17x30x1	Thrust washer 17x30x1	Rondelle de butée 17x30x1	Anlaufscheibe 17x30x1	Arandela distanciadora 17x30x1
21	12.95605.000	1		Cuscinetto 6203	Bearing 6203	Roulement 6203	Lager 6203	Cojinete 6203
22	27.72560.000	2		Rondella spessoramento 18x27	Spacer washer 18x27	Entretoise 18x27	Distanzscheibe 18x27	Arandela distanciadora 18x27
23	026.06.031.80.00	1		Ingranaggio rinvio m.m.	Kickstart idler gear	Pignon de renvoi de démarrage	Zwischenrad starter	Engr. de reenvío arranque
24	28.24955.000	2		Seeger 17x1,5	Circlip 17x1,5	Circlip 17x1,5	Seeger 17x1,5	Seeger 17x1,5

# Tav.05

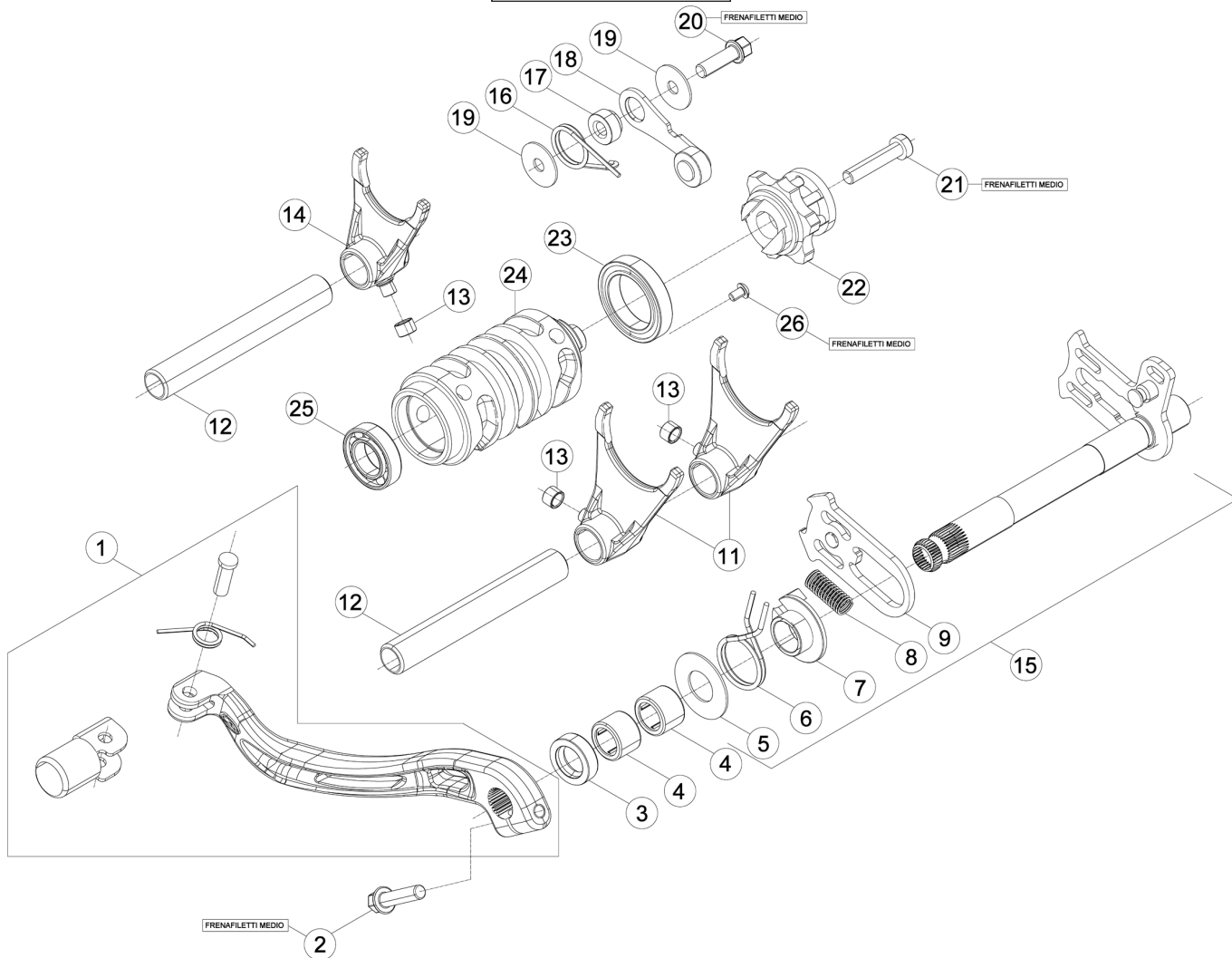

Pos Loc Pos Ps Pos	Numero Number Numéro Número Nummer	Q.tà Q.ty Q.té M.ge C.ad	Nota Note Note Nota Anm.	Descrizione	Description	Désignation	Beschreibung	Descripción
1	006.05.000.80.00	1		Leva comando cambio	Gear change lever	Levier comm. chang. vit.	Schalthebel	Palanca cambio
2	11.50010.000	1		Bullone M6x25	Bolt M6x25	Boulon M6x25	Bolzen M6x25	Tornillo M6x25
3	10.52012.000	1		Anello paraolio 14x24.6	Oil seal 14x24.6	Joint d' é tanché ité 14x24.6	Ölschutzring 14x24.6	Retén de aceite 14x24.6
4	11.22320.000	2		Boccola a rulli	Roller bearing	Douille à roulements	Rollenbuchse	Caja de grasa de rodillos
5	27.63020.000	1		Rondella rasamento 14x30x1	Thrust washer 14x30x1	Rondelle de buté e 14x30x1	Anlaufscheibe 14x30x1	Arandela distanciadora 14x30x1
6	006.05.017.00.00	1		Molla ritorno comando cambio	Gearchange return spring	R ressort de retour comm. ch.ge vit.	Rückstellfeder schaltung	Muelle de retorno cambio
7	16.92911.000	1		Guida molla	Spring guide	Guide ressort	Federführung	Guia de resorte
8	006.05.016.00.00	1		Molla 0,8MM	Spring 0,8MM	R ressort 0,8MM	Feder 0,8MM	Muelle 0,8MM
9	006.05.014.80.00	1		Ventaglio mobile	Movable pawl	Eventail mobile	Schaltautomat	Abanico mó vil
11	006.05.020.00.00	2		Forchetta 1/4	Fork 1/4	Fourchette 1/4	Schaltgabel 1/4	Horquilla 1/4
12	026.05.025.00.00	2		Perno forchetta	Spindle, fork	Axe de fourche	Schaltgabelstift	Perno de la horquilla
13	006.05.027.00.00	3		Boccola 6x8.5.2.	Bush 6x8.5.2.	Moyeu 6x8.5.2.	Bü chse 6x8.5.2.	Buje 6x8.5.2.
14	006.05.021.00.00	1		Forchetta 5/6	Fork 5/6	Fourchette 5/6	Schaltgabel 5/6	Horquilla 5/6
15	026.05.010.80.00	1		Albero cambio compl.	Gear shaft assy.	Arbre Boi te à vitesse compl.	Getriebewelle kpl.	Eje cambio compl.
16	22.39590.000	1		Molla arresto marce	Gear stop spring	R ressort arrê t vit.	Gangstoppfeder	Muelle arresto vel.
17	006.05.054.00.00	1		Distanziale	Spacer	Entretoise	Distanzstü ck	Distanciadador
18	026.05.050.80.00	1		Leva arresto marce	Gear stop lever	Levier arrê t vit.	Gangstopphebel	Palanca arresto vel.
19	27.42000.100	2		Rondella 6x20.1,0	Washer 6x20.1,0	Rondelle 6x20.1,0	U.Scheibe 6x20.1,0	Arandela 6x20.1,0
20	11.49070.000	1		Bullone 6x20 ch rs	Bolt 6x20 ch rs	Boulon 6x20 ch rs	Bolzen 6x20 ch rs	Tornillo 6x20 ch rs
21	31.45000.000	1		Vite TCCE 6.30	Screw TCCE 6.30	Vis TCCE 6.30	Schraube TCCE 6.30	Tornillo TCCE 6.30
22	006.05.040.80.00	1		Camma Arresto Marce	Gear Stopper Cam	Came Buté e Vitesses	Gangsperrnocken	Leva Parada Marchas
23	12.93405.000	1		Cuscinetto 61805	Bearing 61805	Roulement 61805	Lager 61805	Cojinete 61805
24	026.05.030.00.00	1		Camma cambio	Selector drum	Barillet de sé lection de boi te de vit.	Schaltwalze	Leva de la caja de cambios
25	12.93840.000	1		Cuscinetto 15x28x7	Bearing 15x28x7	Roulement 15x28x7	Lager 15x28x7	Cojinete 15x28x7
26	31.30084.000	1		Vite M5X8	Screw M5X8	Vis M5X8	Schraube M5X8	Tornillo M5X8



# Tav.06

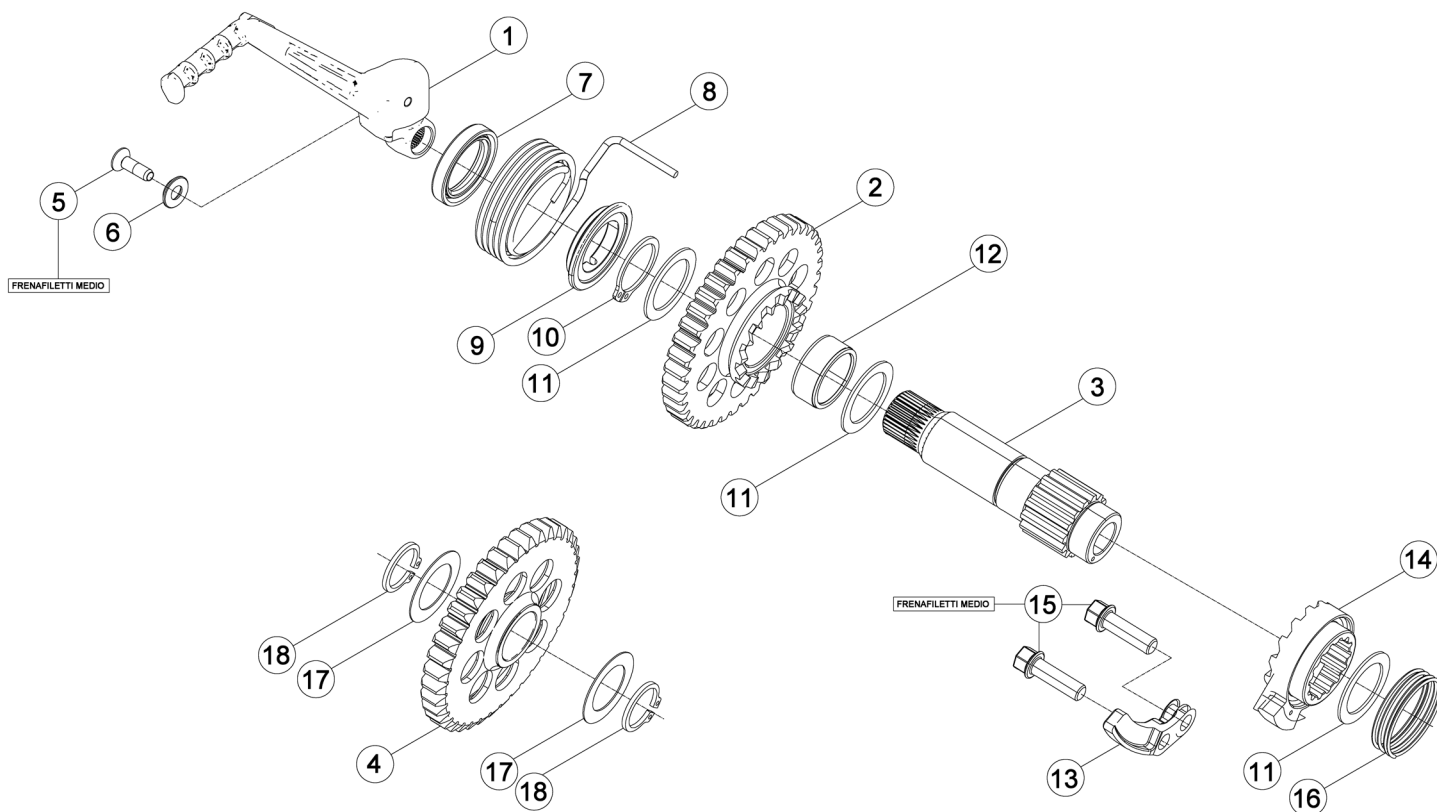

Pos Loc Pos Ps Pos	Numero Number Numéro Número Nummer	Q.tà Q.ty Q.té M.ge C.ad	Nota Note Note Nota Anm.	Descrizione	Description	Désignation	Beschreibung	Descripcìon
1	006.06.100.80.00	1		Leva messa in moto completa	Start. lever, assy	Lev.du dé m. complet	Kickstarterhebel, kpl.	Palanca de arranque completa
2	006.06.011.00.00	1		Ingranaggio messa in moto	Kickstart gear	Pignon de dé marriage	Startergetriebe	Engranaje del arranque
3	006.06.010.00.00	1		Albero messa in moto	Kickstarter shaft	Arbre du dé marreur	Starterwelle	Eje puesta en marcha
4	026.06.031.80.00	1		Ingranaggio rinvio m.m.	Kickstart idler gear	Pignon de renvoi de dé marr.	Zwischenrad starter	Engr. de reenvio arranque
5	31.96827.000	1		Vite speciale M8X26	Special screw M8X26	Vis spéciale M8X26	Spezialschraube M8X26	Tornillo especial M8X26
6	006.06.008.00.00	1		Rondella	Washer	Rondelle	U.Scheibe	Arandela
7	10.64490.000	1		Anello paraolio 20x30.5/6	Oil seal 20x30.5/6	Joint d' é tanché ité 20x30.5/6	Ölschutzring 20x30.5/6	Retén de aceite 20x30.5/6
8	006.06.013.00.00	1		Molla richiamo albero messa in moto	Return spring kickstarter shaft	Ressort de rappel arbre du dé marreur	Rückzugsfeder Starterwelle	Muelle de retorno eje puesta en marcha
9	006.06.112.00.00	1		Distanziale messa in moto	Spacer, kickstart	Entretoise dé marriage	Distanzstück starter	Distanciadador del arranque
10	28.25400.000	1		Seeger 20e	Circlip 20e	Circlip 20e	Seeger 20e	Seeger 20e
11	27.73600.100	3		Rondella spessoramento 20x28.1	Spacer washer 20x28.1	Entretoise 20x28.1	Distanzscheibe 20x28.1	Arandela distanciadora 20x28.1
12	11.22835.000	1		Gabbia a rulli 20x24x10	Roller cage 20x24x10	Cage a roul. 20x24x10	Rollenkäfig 20x24x10	Jaula de rod. 20x24x10
13	006.06.016.00.00	1		Rampa messa in moto	Kickstart ramp	Rampe de dé marriage	Starterrampe	Rampa para el arranque
14	006.06.014.00.00	1		Manicotto messa in moto	Kickstart sleeve	Manchon de dé marriage	Muffe starter	Manguito arranque
15	11.49070.000	2		Bullone 6x20 ch rs	Bolt 6x20 ch rs	Boulon 6x20 ch rs	Bolzen 6x20 ch rs	Tornillo 6x20 ch rs
16	006.06.015.00.00	1		Molla	Spring	Ressort	Feder	Muelle
17	27.71220.000	2		Rondella spess. 17.25	Washer 15x25 17.25	Rondelle épaisseur 15x25 17.25	Scheibe 15x25 17.25	Arandela 15x25 17.25
18	001.23.001.00.00	2		Anello di fermo 17x1	Check ring 17x1	Bague d' arrêt 17x1	Sicherungsring 17x1	Anillo de bloqueo 17x1

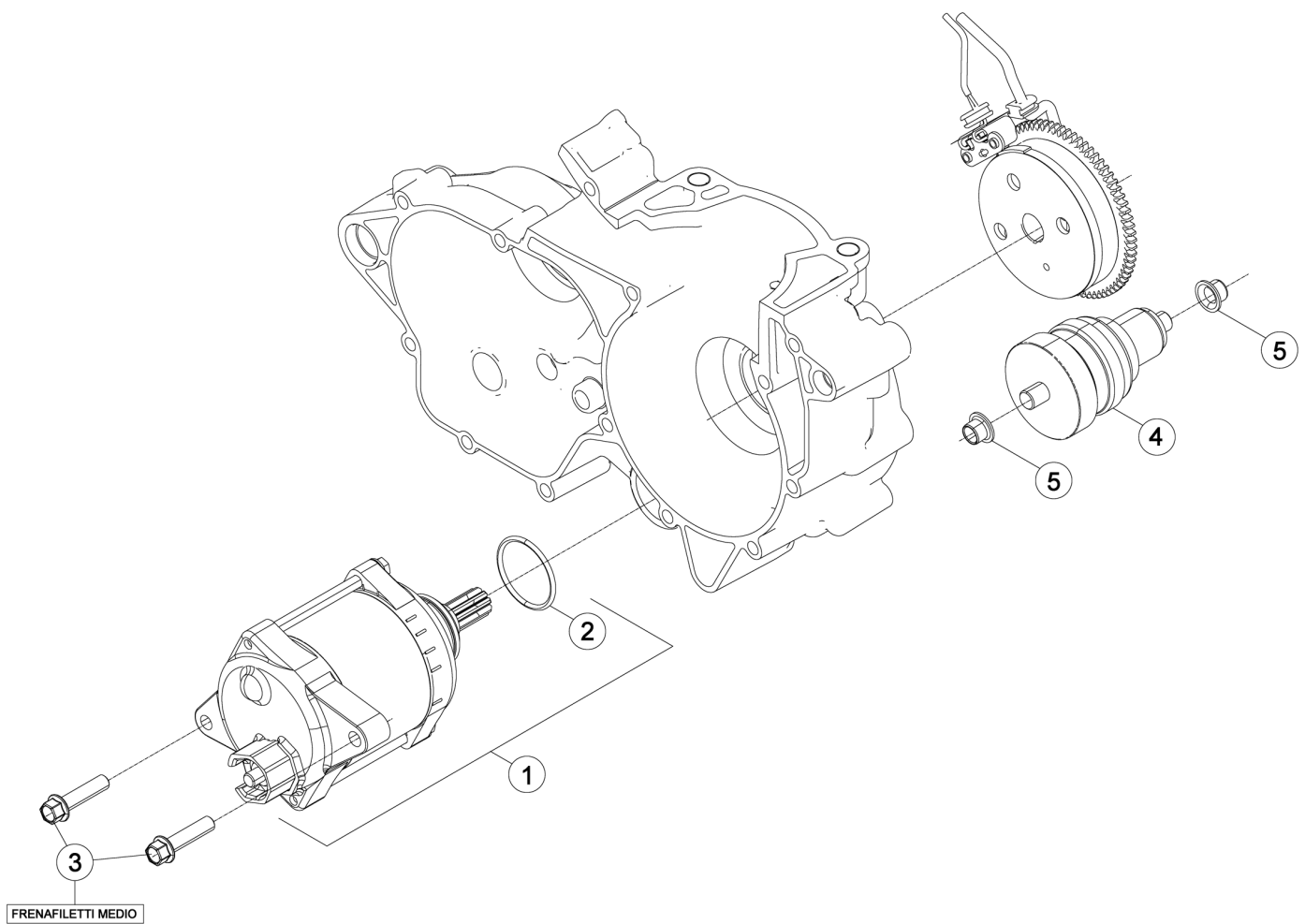

# Tav.07

Pos Loc Pos Ps Pos	Numero Number Numéro Número Nummer	Q.tà Q.ty Q.té M.ge C.ad	Nota Note Nota Nota Anm.	Descrizione	Description	Dé signation	Beschreibung	Descrìcì o n
1	026.07.000.80.00	1		Motorino avviamento	Starter motor	Moteur du dé marreur	Startermotor	Motor de arranque
2	36.25056.000	1		Anello OR 25,00x3,00	O-Ring 25,00x3,00	Bague d' é tanché ité 25,00x3,00	O-Ring 25,00x3,00	Anillo OR 25,00x3,00
3	11.50010.000	2		Bullone M6x25	Bolt M6x25	Boulon M6x25	Bolzen M6x25	Tornillo M6x25
4	026.07.010.00.00	1		Innesto	Contact tag	Cosse	Stecker	Toma de contacto
5	C03.02.001.00.00	2		Boccola 8x10x8	Bush 8x10x8	Moyeu 8x10x8	Büchse 8x10x8	Buje 8x10x8

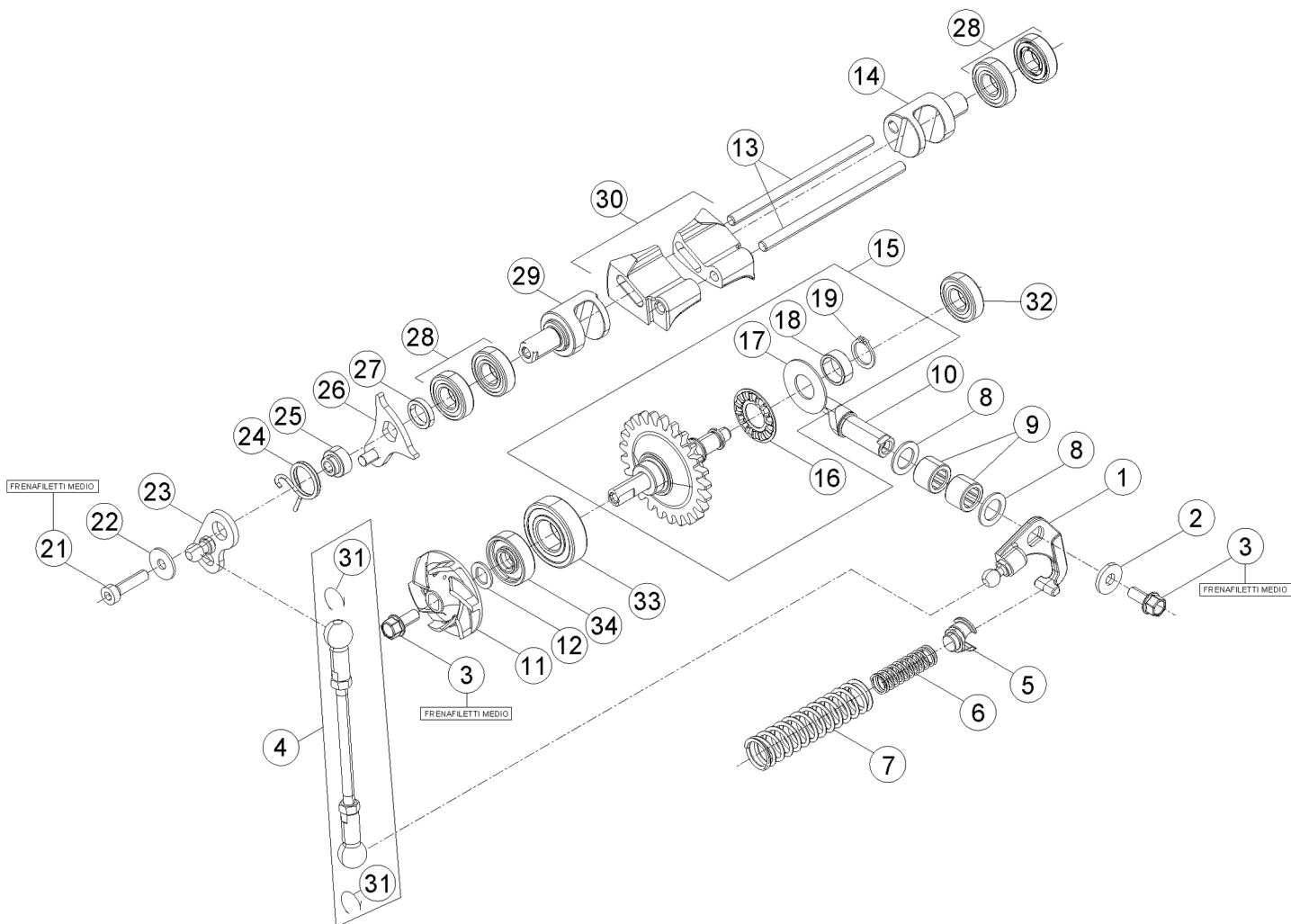



# Tav.09

Pos Loc Ps Pos	Numero Number Numéro Nummer	Q.tà Q.ty Q.té M.ge C.ad	Nota Note Nota Anm.	Descrizione	Description	Dé signation	Beschreibung	Descrìpziò n
1	026.09.013.80.00	1		Bilanciere compl.	Rocker arm assy	Culbuteur compl.	Kipphebel kpl.	Balancì n compl.
2	C16.02.001.00.00	1		Rondella 5.15.2	Washer 5.15.2	Rondelle 5.15.2	U.Scheibe 5.15.2	Arandela 5.15.2
3	11.46251.000	2		Bullone flangiato M5x12	Head Flanged bolt M5x12	Boulon Bridé M5x12	Bundbolzen M5x12	Bulón con Brida M5x12
4	026.09.015.80.00	1		Asta comando valvola	Valve control rod	Tige de commande soupape	Ventilsteuerungsstab	Varilla mando válvula
5	026.09.017.00.00	1		Guida molla	Spring guide	Guide ressort	Federfuehrung	Guia de resorte
6	026.09.018.00.00	1		Molla	Spring	Ressort	Feder	Muelle
7	026.09.021.00.00	1	250cc	Molla regolazione	Adjusting spring	Ressort de réglage	Feder, Einstell	Muelle de regul.
7	026.09.019.00.00	1	300cc	Molla regolazione	Adjusting spring	Ressort de réglage	Feder, Einstell	Muelle de regul.
8	C19.04.001.00.00	2		Rondella 16.10.1	Washer 16.10.1	Rondelle 16.10.1	U.Scheibe 16.10.1	Arandela 16.10.1
9	11.22100.000	2		Boccola a rulli 10x14x10	Roller bearing 10x14x10	Douille à roulements 10x14x10	Rollenbuchse 10x14x10	Caja de grasa de rodillos 10x14x10
10	026.09.011.00.00	1		Leva controllo	Control Lever	Levier De Commande	Steuerhebel	Palanca Control
11	006.09.000.00.00	1		Girante pompa	Rotor	Roue de pompe	Wasserpumpenrad	Rotor de la bomba
12	006.09.012.00.00	1		Rondella	Washer	Rondelle	U.Scheibe	Arandela
13	026.09.031.00.00	2		Perno valvola di scarico	Exhaust valve pin	Pivot soupape d' é chapp.	Stift Auslassventil	Perno válvula de descarga
14	026.09.040.00.00	1		Valvola BOOSTER Sx	BOOSTER valve L.H.	Soupape BOOSTER G.	Auslass BOOSTER L.	Vá lvula BOOSTER izq.
15	026.09.000.80.00	1		Unità centrifuga	Centrifugal unit	Unité centrifuge	Zentrifugaleinheit	Unidad centri fuga
16	16.11512.000	1		Gabbia assiale a rullini	Axial needle collar	Cage à aiguilles axiale	Axial-Nadelkranz	Jaula de agujas del cojinete
17	27.56400.000	1		Ralla	Washer	Rondelle	Scheibe	Arandela
18	026.09.003.00.00	1		Distanziale	Spacer	Entretoise	Distanzstück	Distanciadór
19	28.22760.000	1		Seeger A12	Circlip A12	Circlip A12	Seeger A12	Seeger A12
21	31.30015.000	1		Vite a brugola 5x20	Allen screw 5x20	Vis à 6 pans 5x20	Sechskantschraube 5x20	Tornillo a llave allen 5x20
22	27.36500.000	1		Rondella Ø5	Washer Ø5	Rondelle Ø5	U.Scheibe Ø5	Arandela Ø5
23	026.09.042.85.00	1		Leva comando	Operating lever	Levier commande	Betaetigungshebel	Palanca de mando
24	026.09.046.00.00	1		Molla	Spring	Ressort	Feder	Muelle
25	026.09.044.00.00	1		Distanziale	Spacer	Entretoise	Distanzstück	Distanciadór
26	026.09.043.85.00	1		Leva fine corsa	Travel limit lever	Levier fin de course	Endanschlaghebel	Palanca final de carrera
27	026.09.047.00.00	1		Distanziale	Spacer	Entretoise	Distanzstück	Distanciadór
28	12.93410.000	4		Cuscinetto	Bearing	Roulement	Lager	Cojinete
29	026.09.041.00.00	1		Valvola BOOSTER Dx	BOOSTER valve R.H.	Soupape BOOSTER D.	Auslass BOOSTER R.	Vá lvula BOOSTER der.
30	026.09.132.00.00	1	250cc	Valvola di scarico	Exhaust valve	Soupape d' é chapp.	Auslassventil	Vá lvula de descarga
30	026.09.032.00.00	1	300cc	Valvola di scarico	Exhaust valve	Soupape d' é chapp.	Auslassventil	Vá lvula de descarga
31	C21.31.001.00.00	2		Molla sicurezza	Locking spring	Ressort surete	Sicherungsfeder	Resorte de seguridad
32	12.93387.000	1		Cuscinetto 6.19.6	Bearing 6.19.6	Roulement 6.19.6	Lager 6.19.6	Cojinete 6.19.6
33	C06.01.001.00.00	1		Cuscinetto 15.32.9 6002-2RSH C3	Bearing 15.32.9 6002-2RSH C3	Roulement 15.32.9 6002-2RSH C3	Lager 15.32.9 6002-2RSH C3	Cojinete 15.32.9 6002-2RSH C3
34	10.43720.000	1		Anello paraolio 8.24.7	Oil seal 8.24.7	Joint d' é tanché ité 8.24.7	Ölschutzring 8.24.7	Retén de aceite 8.24.7

# Tav.10

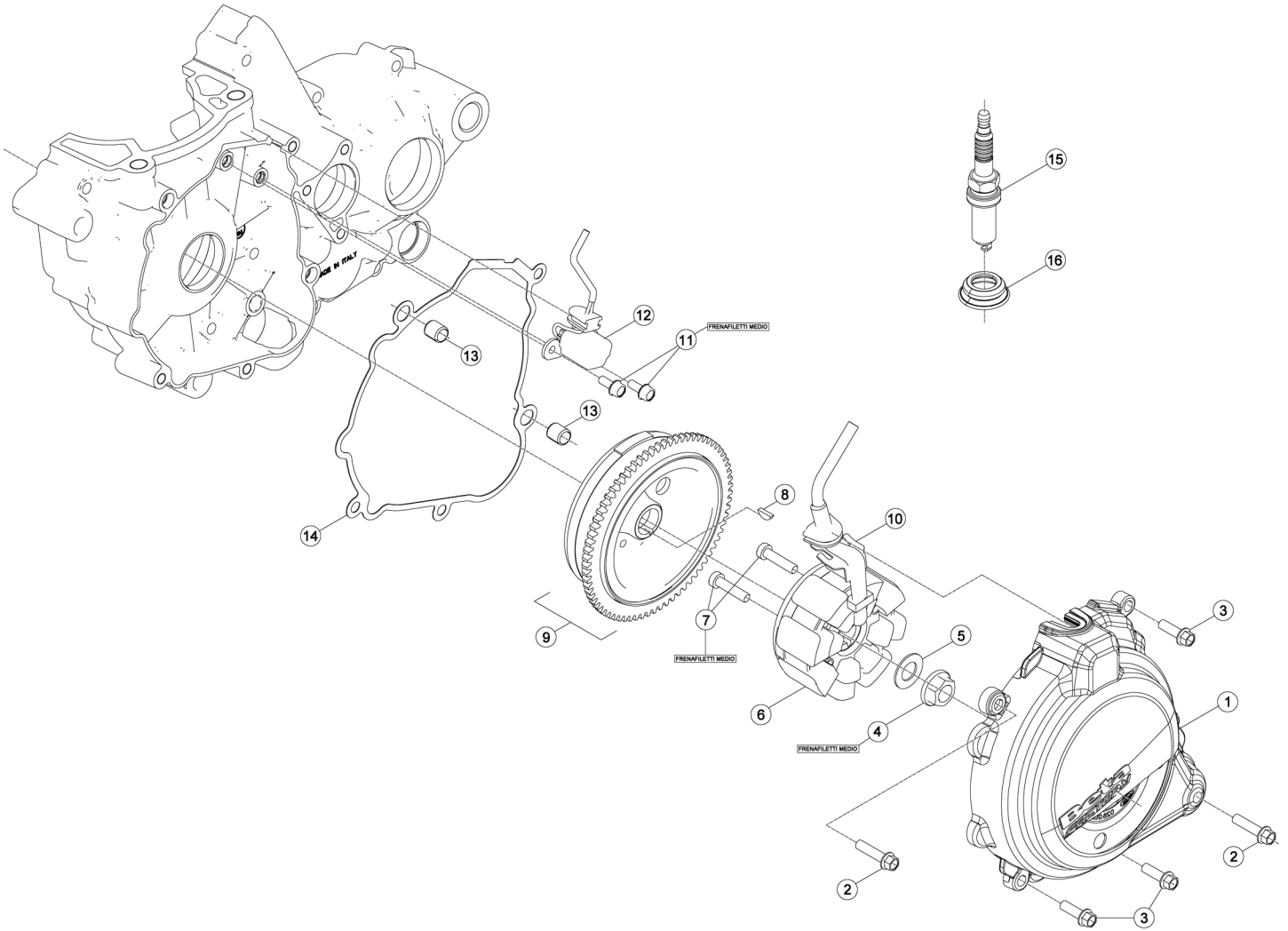

# Tav.10

Pos Loc Ps Pos	Numero Number Numéro Número Nummer	Q.tà Q.ty Q.té M.ge C.ad	Nota Note Nota Anm.	Descrizione	Description	Dé signation	Beschreibung	Descrìpziò n
1	026.01.051.80.52	1		Coperchio volano	Flywheel cover	Carter volant	Schwungraddeckel	Tapa volante
2	11.50010.000	2		Bullone M6x25	Bolt M6x25	Boulon M6x25	Bolzen M6x25	Tornillo M6x25
3	11.49070.000	3		Bullone 6x20 ch rs	Bolt 6x20 ch rs	Boulon 6x20 ch rs	Bolzen 6x20 ch rs	Tornillo 6x20 ch rs
4	13.25010.000	1		Dado M12x1	Nut M12x1	Ecrou M12x1	Mutter M12x1	Tuerca M12x1
5	27.74810.000	1		Rondella elastica	Spring Washer	Rondelle é lastique	Federring	Arandela elástica
6	006.10.020.00.00	1		Statore	Backplate	Stator	Ankerplatte	Estatore
7	31.48507.000	2		Vite tce testa ribassata M6x25	Screw tce, shallow head M6x25	Vis tce à tête basse M6x25	Schraube tce senkkopf M6x25	Tornillo tce de cabeza rebajada M6x25
8	12.46020.000	1		Chiavetta 3x5	Key 3x5	Clavette 3x5	Keil 3x5	Chaveta 3x5
9	026.10.001.85.00	1		Rotore volano	Flywheel rotor	Rotor volant	Rotor schwungrad	Rotor volante
10	006.01.054.00.00	1		Piastrina	Plate	Plaque	Plättchen	Placa
11	11.46251.000	2		Bullone flangiato M5x12	Head Flanged bolt M5x12	Boulon Bridé M5x12	Bundbolzen M5x12	Bulón con Brida M5x12
12	026.10.003.00.00	1		Pick up	Pick-up	Capteur	Pick-up	Pick-up
13	16.36500.000	2		Grano 9x7,2x10	Dowel 9x7,2x10	Goujon 9x7,2x10	Stift 9x7,2x10	Clavija 9x7,2x10
14	026.01.053.00.00	1		Guarnizione coperchio volano	Alternator cover gasket	Garniture couvercle alternateur	Alternatordeckeldichtung	Junta tapa alternador
15	12.25123.000	1	250cc	Candela	Spark.plug	Bougie	Zundkerze	Bujia
15	036.11.000.00.00	1	300cc	Candela	Spark.plug	Bougie	Zundkerze	Bujia
16	026.10.012.00.00	1		Guarnizione candela	Spark plug gasket	Joint bougie		Junta bujia

# Tav.11

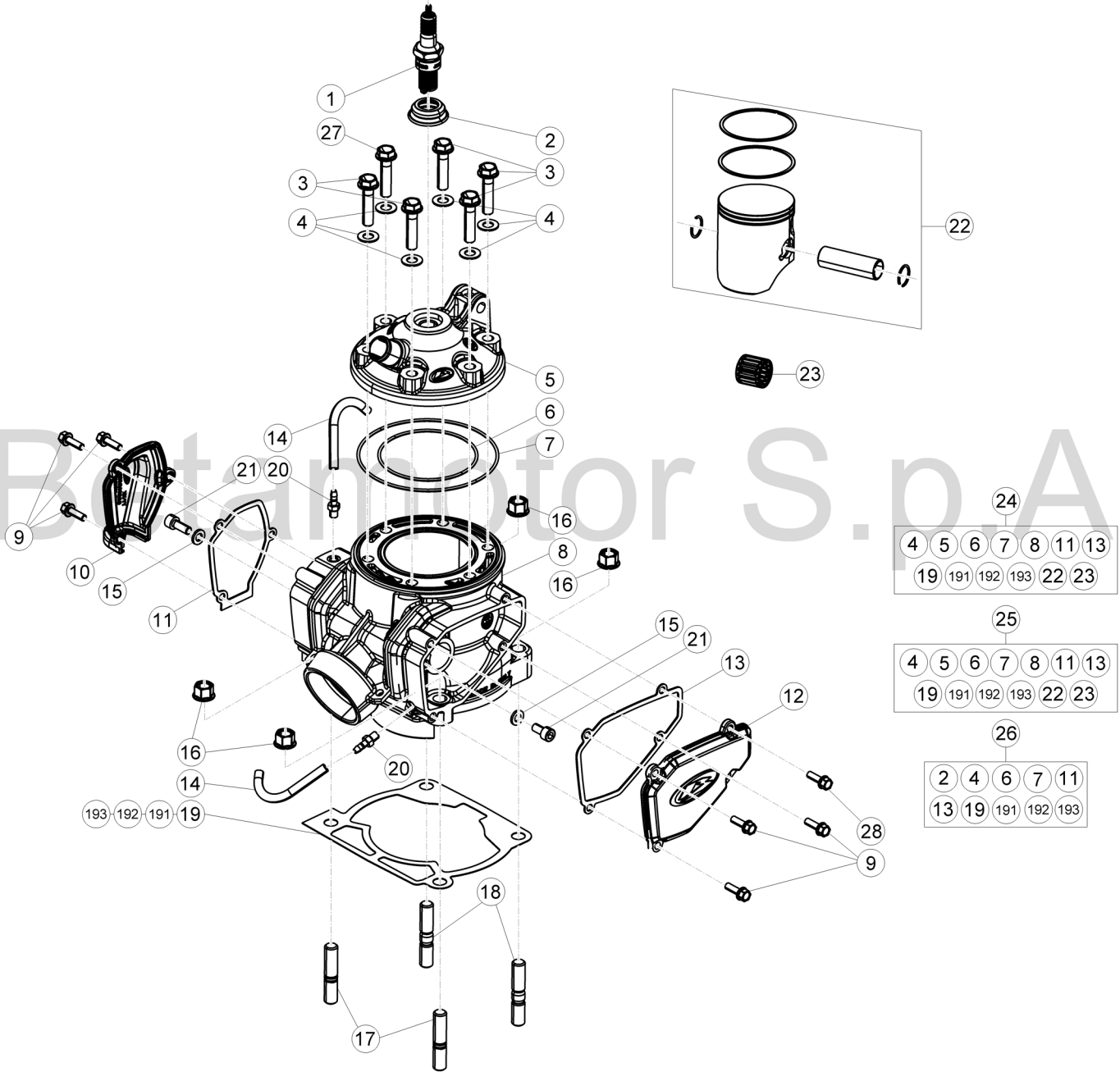

© Copyright 2016 Betamotor S.p.A.

# Tav.11

Pos Loc Ps Pos	Numero Number Numéro Nummer	Q.tà Q.ty Q.té M.ge C.ad	Nota Note Note Anm.	Descrizione	Description	Dé signation	Beschreibung	Descrìpziò n
1	12.25123.000	1	250cc	Candela	Spark plug	Bougie	Zündkerze	Bujia
1	036.11.000.00.00	1	300cc	Candela	Spark plug	Bougie	Zündkerze	Bujia
2	026.10.012.00.00	1		Guarnizione candela	Spark plug gasket	Joint bougie	Zündkerzendichtring	Junta bujia
3	026.11.011.00.00	5		Vite flangiata M8x35	Flange bolt M8x35	Boulon de bride M8x35	Flanschschraube M8x35	Perno de reborde M8x35
4	026.11.010.00.00	6		Rosetta 8.16.1	Washer 8.16.1	Rondelle 8.16.1	Federring 8.16.1	Arandela 8.16.1
5	026.11.017.80.52	1	250cc	Testa completa	Cylinder head	Culasse complete	Zylinderkopf Kpl.	Culata completa
5	026.11.014.80.52	1	300cc	Testa completa	Cylinder head	Culasse complete	Zylinderkopf Kpl.	Culata completa
6	10.66972.000	1	250cc	Anello OR 73.2	O-Ring 73.2	Bague d' é tanché ité 73.2	O-Ring 73.2	Anillo OR 73.2
6	10.66973.000	1	300cc	Anello OR 78.2	O-Ring 78.2	Bague d' é tanché ité 78.2	O-Ring 78.2	Anillo OR 78.2
7	10.66978.000	1		Anello OR 105.2	O-Ring 105.2	Bague d' é tanché ité 105.2	O-Ring 105.2	Anillo OR 105.2
8	026.11.016.00.0A	1	250cc	Cilindro	Cylinder	Cylindre	Zylinder	Cilindro
8	026.11.016.00.0B	1	250cc	Cilindro	Cylinder	Cylindre	Zylinder	Cilindro
8	026.11.101.00.0A	1	300cc	Cilindro	Cylinder	Cylindre	Zylinder	Cilindro
8	026.11.101.00.0B	1	300cc	Cilindro	Cylinder	Cylindre	Zylinder	Cilindro
9	11.46360.000	6		Bullone flangiato M5x16	Head Flanged bolt M5x16	Boulon Bridé M5x16	Bundbolzen M5x16	Bulón con Brida M5x16
10	026.11.002.20.00	1		Coperchio valvola Dx.	Right valve head cover	Couvercle soupape D.	Ventilabdeckung rechts	Tapa válvula der.
11	026.11.003.00.00	1		Guarnizione coperchio valvola dx.	Right valve cover gasket	Garniture couvercle soupape D.	Ventildeckeldichtung rechts	Junta tapa válvula der.
12	026.11.004.00.52	1		Coperchio valvola Sx.	Left valve head cover	Couvercle soupape G.	Ventilabdeckung links	Tapa válvula izq.
13	026.11.005.00.00	1		Guarnizione coperchio valvola sx.	Left valve cover gasket	Garniture couvercle soupape G.	Ventildeckeldichtung links	Junta tapa válvula izq.
14	026.11.012.00.00	2		Tube benzina	Petrol tube	Tuyau d' essence	Benzinschlauch	Tube gasolina
15	27.40500.000	2		Rondella 6x13	Washer 6x13	Rondelle 6x13	U.Scheibe 6x13	Arandela 6x13
16	13.20210.000	4		Dado speciale M10x1,25 ch 13	Special nut M10x1,25 ch 13	Ecrou spéciale M10x1,25 ch 13	Spezialmutter M10x1,25 ch 13	Tuerca especial M10x1,25 ch 13
17	C24.76.001.00.00	2		Prigioniero M10x30x1,25	Stud M10x30x1,25	Goujon M10x30x1,25	Stiftschraube M10x30x1,25	Espá rrago M10x30x1,25
18	C24.76.002.00.00	2		Prigioniero M10x35x1,25	Stud M10x35x1,25	Goujon M10x35x1,25	Stiftschraube M10x35x1,25	Espá rrago M10x35x1,25
19	026.11.025.00.00	1		Guarnizione base cilindro Sp. 0,3	Cylinder base gasket Sp. 0,3	Garniture base cylindre Sp. 0,3	Dichtung für Zylinderfuß Sp. 0,3	Junta base cilindro Sp. 0,3
191	026.11.026.00.00	1		Guarnizione base cilindro Sp. 0,4	Cylinder base gasket Sp. 0,4	Garniture base cylindre Sp. 0,4	Dichtung für Zylinderfuß Sp. 0,4	Junta base cilindro Sp. 0,4
192	026.11.027.00.00	1		Guarnizione base cilindro Sp. 0,5	Cylinder base gasket Sp. 0,5	Garniture base cylindre Sp. 0,5	Dichtung für Zylinderfuß Sp. 0,5	Junta base cilindro Sp. 0,5
193	026.11.028.00.00	1		Guarnizione base cilindro Sp. 0,6	Cylinder base gasket Sp. 0,6	Garniture base cylindre Sp. 0,6	Dichtung für Zylinderfuß Sp. 0,6	Junta base cilindro Sp. 0,6
20	29.00280.000	2		Tappo presa dep.	Air Vent Plug	Bouchon prise dep.	Verschluss f. Lufteinlass	Tapón Toma Aire dep.
21	31.31050.000	2		Vite t.c.c.e.M6x15	Screw t.c.c.e.M6x15	Vis t.c.c.e.M6x15	Schraube t.c.c.e.M6x15	Tornillo t.c.c.e.M6x15
22	026.02.024.80.0A	1	250cc	Pistone completo - Sel. A	Piston set - Sel. A	Piston compl. - Sé l. A	Kolben, kompl. - Auswahl A	Pistón, compl. - Sel. A
22	026.02.024.80.0B	1	250cc	Pistone completo - Sel. B	Piston set - Sel. B	Piston compl. - Sé l. B	Kolben, kompl. - Auswahl B	Pistón, compl. - Sel. B
22	026.02.024.80.0C	1	250cc	Pistone completo - Sel. C	Piston set - Sel. C	Piston compl. - Sé l. C	Kolben, kompl. - Auswahl C	Pistón, compl. - Sel. C
22	026.02.032.80.0A	1	300cc	Pistone completo - Sel. A	Piston set - Sel. A	Piston compl. - Sé l. A	Kolben, kompl. - Auswahl A	Pistón, compl. - Sel. A
22	026.02.032.80.0B	1	300cc	Pistone completo - Sel. B	Piston set - Sel. B	Piston compl. - Sé l. B	Kolben, kompl. - Auswahl B	Pistón, compl. - Sel. B
22	026.02.032.80.0C	1	300cc	Pistone completo - Sel. C	Piston set - Sel. C	Piston compl. - Sé l. C	Kolben, kompl. - Auswahl C	Pistón, compl. - Sel. C
23	16.16710.000	1		Gabbia	Cage	Cage	Lagerkä fig	Jaula
24	026.11.112.82.0A	1	250cc	Kit gruppo termico - Sel. A	Thermal unit kit- Sel. A	Jeu groupe thermique - Sé l. A	Satz für Thermischen Gruppe -	Serie revisió n grupo té rmico -
24	026.11.112.82.0B	1	250cc	Kit gruppo termico - Sel. B	Thermal unit kit- Sel. B	Jeu groupe thermique - Sé l. B	Satz für Thermischen Gruppe -	Serie revisió n grupo té rmico -
25	026.11.114.82.0A	1	300cc	Kit gruppo termico - Sel. A	Thermal unit kit- Sel. A	Jeu groupe thermique - Sé l. A	Satz für Thermischen Gruppe -	Serie revisió n grupo té rmico -
25	026.11.114.82.0B	1	300cc	Kit gruppo termico - Sel. B	Thermal unit kit- Sel. B	Jeu groupe thermique - Sé l. B	Satz für Thermischen Gruppe -	Serie revisió n grupo té rmico -
26	026.11.113.82.00	1		Kit guarnizioni gruppo termico	Thermal unit gasket set	Jeu joints groupe thermique	Dichtungssatz kompl.	Juego juntas grupo té rmico
27	026.11.037.00.00	1		Vite di sicurezza	Tab screw	Vis de sû reté	Sicherungs-Schraube	Tornillo de seguridad
28	026.11.036.00.00	1		Vite di sicurezza	Tab screw	Vis de sû reté	Sicherungs-Schraube	Tornillo de seguridad

# Tav.12

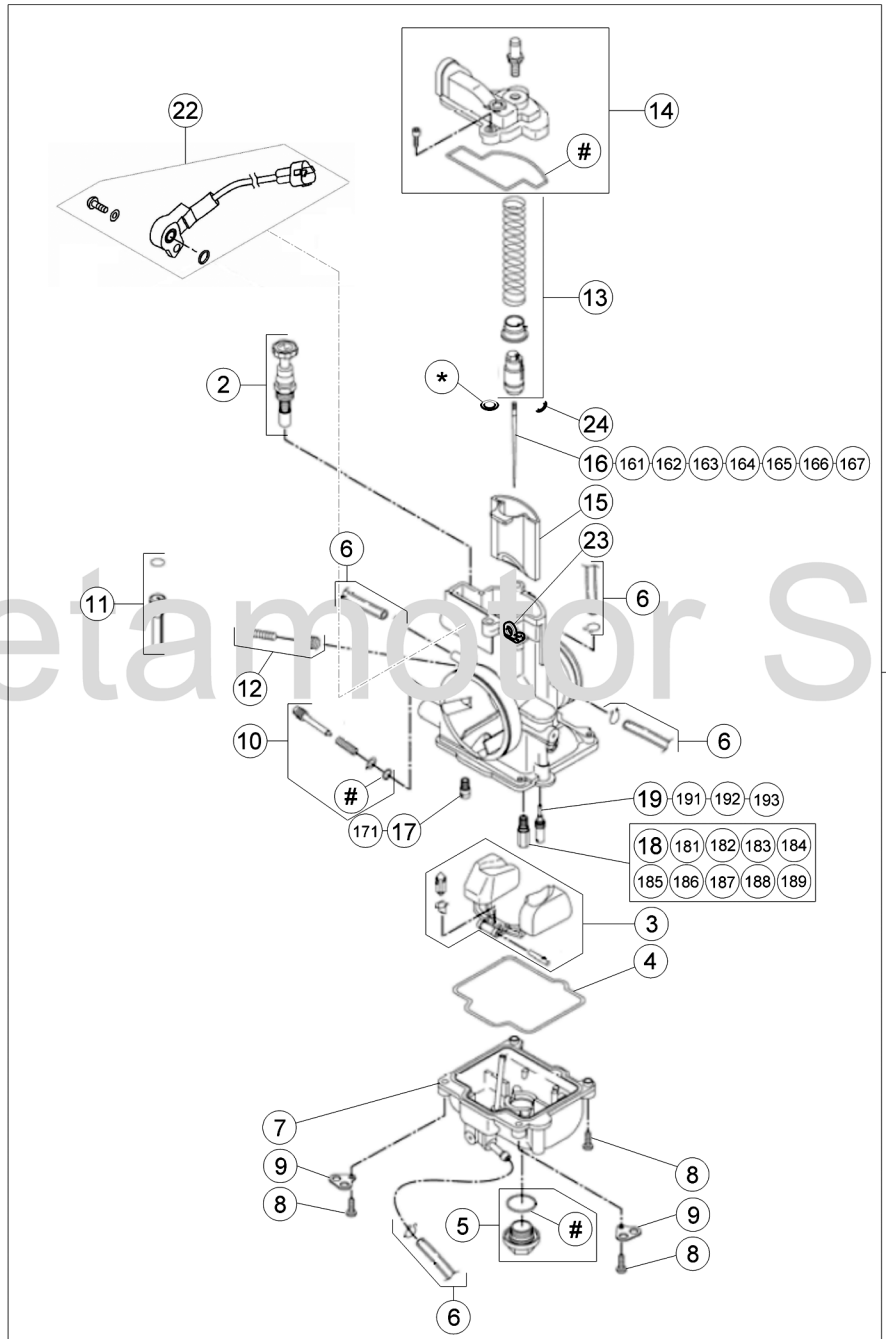

© Copyright 2016 Betamotor S.p.A.





# Tav.12

Pos Loc Pos Ps Pos	Numero Number Numé ro Número Nummer	Q.tà Q.ty Q.té M.ge C.ad	Nota Note Note Nota Anm.	Descrizione	Description	Dé signation	Beschreibung	Descrìpziò n
1	026.12.052.80.00	1	250cc	Carburatore	Carburettor	Carburateur	Vergaser	Carburador
1	026.12.051.80.00	1	300cc	Carburatore	Carburettor	Carburateur	Vergaser	Carburador
2	026.12.008.00.00	1		Pistone starter	Starter piston	Piston starter	Kolben starter	Pistón starter
3	026.12.009.80.00	1		Galleggiante	Float	Flotteur	Schwimmer	Flotador
4	026.12.011.00.00	1		Guarnizione vaschetta	Float chamber gasket	Joint vase essence	Dichtung Schwimmergehäuse	Junta cuba
5	026.12.106.80.00	1		Tappo vaschetta carburatore	Cap drain	Bouchon	Verschluss	Tapón
6	026.12.045.00.00	1		Kit tubi sfiato	Breather pipes kit	Kit tuyaux reniflard	Kit Entlüftungsleitungen	Kit tubos respiraderos
7	026.12.107.00.00	1		Vaschetta completa	Chamber assy.	Cuvette compl.	Becken kpl	Cubeta compl.
8	026.12.016.00.00	3		Vite M4x16	Screw M4x16	Vis M4x16	Schraube M4x16	Tornillo M4x16
9	026.12.024.00.00	2		Piastrina	Plate	Plaque	Plättchen	Placa
10	026.12.028.80.00	1		Vite di regolazione	Adjusting screw	Vis de réglage	Schraube, Einstell	Tornillo de regul.
11	026.12.006.80.00	1		Distanziale	Spacer	Entretoise	Distanzstück	Distanciadór
12	026.12.032.80.00	1		Vite di regolazione	Adjusting screw	Vis de réglage	Schraube, Einstell	Tornillo de regul.
13	026.12.037.80.00	1		Molla valvola	Valve spring	Ressort soupape	Ventilfeder	Muelle válvula
14	026.12.039.80.00	1		Coperchio carburatore	Carburettor cover	Couvercle carburateur	Abdeckung Vergaser	Tapa carburador
15	026.12.105.00.00	1		Valvola Carburatore	Carb Valve	Soupape Carburateur	Vergaserventil	Válvula Carb.
16	026.12.019.00.00	1	300cc	Spillo N2ZJ-300 cc	Needle N2ZJ-300 cc	Pointeau N2ZJ-300 cc	Düsenadel N2ZJ-300 cc	Aguja N2ZJ-300 cc
161	026.12.018.00.00	1	300cc	Spillo N2ZW-300 cc	Needle N2ZW-300 cc	Pointeau N2ZW-300 cc	Düsenadel N2ZW-300 cc	Aguja N2ZW-300 cc
162	026.12.020.00.00	1	300cc	Spillo N2ZK-300 cc	Needle N2ZK-300 cc	Pointeau N2ZK-300 cc	Düsenadel N2ZK-300 cc	Aguja N2ZK-300 cc
163	026.12.017.00.00	1		Spillo N84K-OMOL	Needle N84K-OMOL	Pointeau N84K-OMOL	Düsenadel N84K-OMOL	Aguja N84K-OMOL
164	026.12.021.00.00	1	300cc	Spillo N2ZH-300cc	Needle N2ZH-300cc	Pointeau N2ZH-300cc	Düsenadel N2ZH-300cc	Aguja N2ZH-300cc
165	026.12.022.00.00	1	250cc	Spillo NOZK-250cc	Needle NOZK-250cc	Pointeau NOZK-250cc	Düsenadel NOZK-250cc	Aguja NOZK-250cc
166	026.12.023.00.00	1	250cc	Spillo NOZJ-250cc	Needle NOZJ-250cc	Pointeau NOZJ-250cc	Düsenadel NOZJ-250cc	Aguja NOZJ-250cc
167	026.12.050.00.00	1	250cc	Spillo NOZI-250cc	Needle NOZI-250cc	Pointeau NOZI-250cc	Düsenadel NOZI-250cc	Aguja NOZI-250cc
17	026.12.046.00.00	1	250cc	Getto starter 85	Starter jet 85	Gicleur starter 85	Starterdüse 85	Surtidor starter 85
171	026.12.005.00.00	1		Getto starter 50	Starter jet 50	Gicleur starter 50	Starterdüse 50	Surtidor starter 50
18	16.42304.000	1		Getto massimo 118	Main jet 118	Gicleur maxi 118	Hauptdüse 118	Surtidor máximo 118
181	36.25104.000	1		Getto massimo 155	Main jet 155	Gicleur maxi 155	Hauptdüse 155	Surtidor máximo 155
182	36.25105.000	1		Getto massimo 158	Main jet 158	Gicleur maxi 158	Hauptdüse 158	Surtidor máximo 158
183	36.25106.000	1		Getto massimo 160	Main jet 160	Gicleur maxi 160	Hauptdüse 160	Surtidor máximo 160
184	36.25107.000	1	250cc	Getto massimo 162	Main jet 162	Gicleur maxi 162	Hauptdüse 162	Surtidor máximo 162
185	36.25108.000	1		Getto massimo 165	Main jet 165	Gicleur maxi 165	Hauptdüse 165	Surtidor máximo 165
186	36.25109.000	1		Getto massimo 168	Main jet 168	Gicleur maxi 168	Hauptdüse 168	Surtidor máximo 168
187	36.25110.000	1		Getto massimo 170	Main jet 170	Gicleur maxi 170	Hauptdüse 170	Surtidor máximo 170
188	36.25111.000	1		Getto massimo 172	Main jet 172	Gicleur maxi 172	Hauptdüse 172	Surtidor máximo 172
189	36.25112.000	1		Getto massimo 175	Main jet 175	Gicleur maxi 175	Hauptdüse 175	Surtidor máximo 175
19	16.42357.000	1	250cc	Getto minimo 35	Starter jet 35	Gicleur starter 35	Starterdüse 35	Surtidor starter 35
191	16.42355.000	1	300cc	Getto minimo 38	Starter jet 38	Gicleur starter 38	Starterdüse 38	Surtidor starter 38
192	026.12.007.00.00	1		Getto minimo 40	Starter jet 40	Gicleur starter 40	Starterdüse 40	Surtidor starter 40
193	16.42347.000	1		Getto minimo 42	Starter jet 42	Gicleur starter 42	Starterdüse 42	Surtidor starter 42
20	026.12.044.00.00	1		Kit guarnizioni	Packings kit	Jeu joints	Dichtungssatz	Grupo juntas
21	026.45.003.80.00	1	250cc	Kit carburatore	Carburetor kit	Kit carburateur	Vergaser Kit	Kit carburador
21	026.45.004.80.00	1	300cc	Kit carburatore	Carburetor kit	Kit carburateur	Vergaser Kit	Kit carburador
22	036.12.004.00.00	1		Sensore posizione valvola a farfalla	Throttle Position Sensor	Sensor Position Valve	Sensor Gasschieberposition	Sensor Válvula
23	25.57912.000	1		Piastrina fissaggio molla collettore	Retaining plate, manifold spring	Plaque de fixation ressort de coll.	Befestigungsplatte Krümmerfeder	Pastilla de fijación del muelle colector
24	12.54242.000	1		Clip carburatore	Carburetor clip	Carburateur clip	Clip Vergaser	Clip carburador

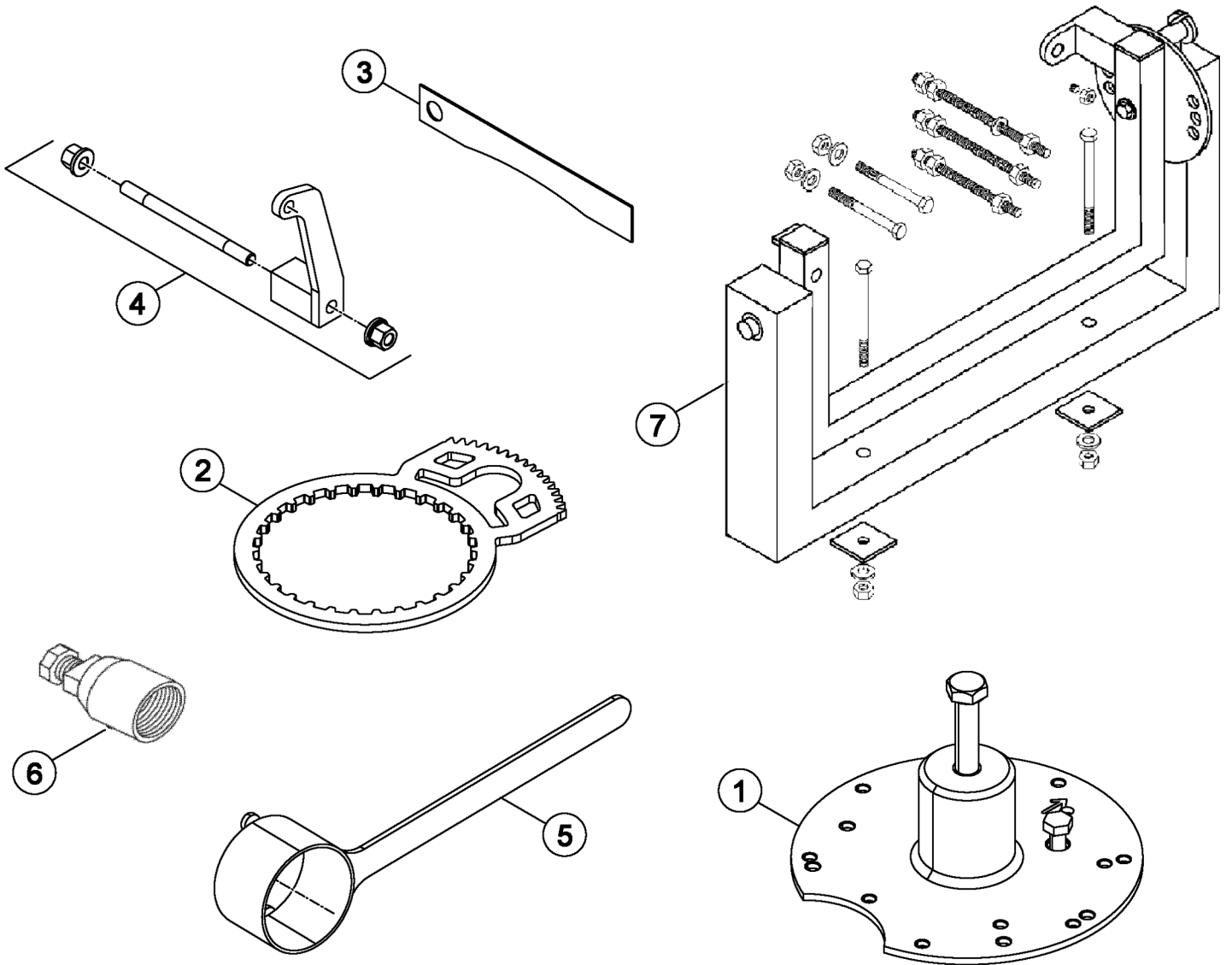

# Tav.14

Pos Loc Pos Ps Pos	Numero Number Numéro Número Nummer	Q.tà Q.ty Q.té M.ge C.ad	Nota Note Nota Nota Anm.	Descrizione	Description	Dé signation	Beschreibung	Descrìciò n
1	007.14.010.80.00	1		Disaccoppiatore carter	Crankcase splitter	Sé parateur de carter	Entkoppler gehäuse	Desacoplador del cárter
2	026.14.001.00.00	1		Attrezzo bloccaggio trasmissione primaria	Holding Tool, Primary drive	Clé de fixation de la transmission principale	Halteschlüssel für Hauptantrieb	Llave para bloquear la transmisión primaria
3	026.14.002.00.00	1		Strumento misura squish	Squish measuring tool	Outil de mesure du squish	Werkzeug für Quetschkante ausmessen	Herramienta para medir el squish
4	026.14.003.00.00	1		Staffa supporto motore	Engine support bracket	Bride support moteur	Motorsattelbefestigung	Brida soporte motor
5	026.14.005.50.00	1		Attrezzo bloccaggio volano	Holding Tool, Flywheel	Clé de fixation volant	Halteschlüssel für Schwungrad	Llave para sostener el volante
6	36.25173.000	1		Estrattore volano	Flywheel extractor	Extracteur pour volant	Auszieher für Schwungrad	Extractor volante
7	36.25132.000	1		Attrezzatura Mont. Motore	Mounting Rack	Outils Montage Moteur	Montagebock	Aparejos Montaje Motor

# Tav.31

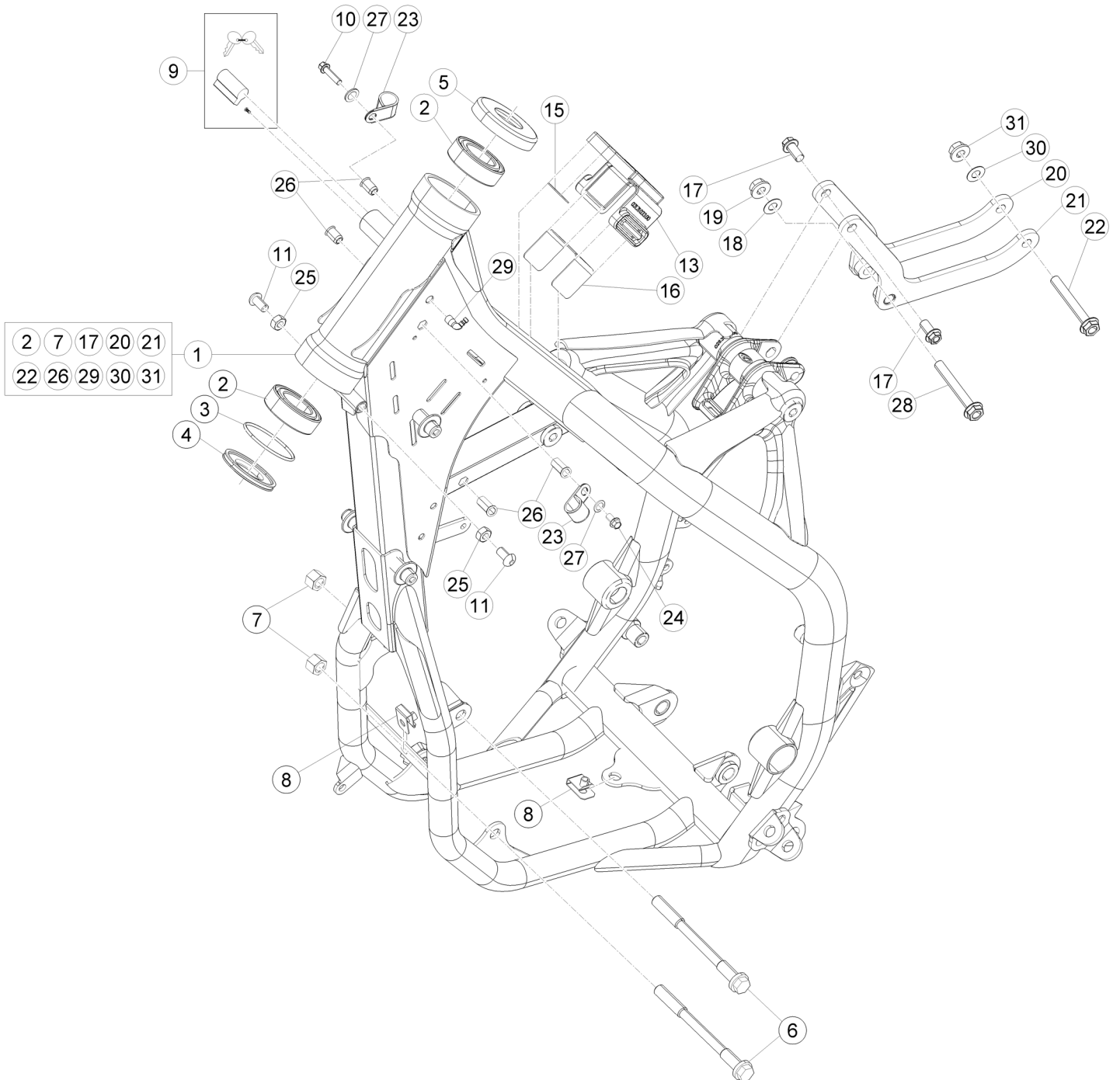

# Tav.31

Pos Loc Ps Pos	Numero Number Numéro Número Nummer	Q.tà Q.ty Q.té M.ge C.ad	Nota Note Note Nota Anm.	Descrizione	Description	Dé signation	Beschreibung	Descrìpziò n
1	026.31.060.80.50	1		Telaio completo	Frame, assy	Chassis complet	Rahmen, kpl	Bastidor compl.
2	12.99510.000	2		Cuscinetto conico 29x50x15	Conical bearing 29x50x15	Roulement conique 29x50x15	Lager 29x50x15	Cojnete conico 29x50x15
3	10.66935.000	1		Anello OR	O-Ring	Bague d' é tanché ité	O-Ring	Anillo OR
4	020.31.039.00.00	1		Anello parapolvere	Dust cover	Disque pare-poussié re	Staubdeckel	Disco gurdapolvo
5	25.98782.000	1		Protezione cuscinetto	End Cap Bearing	Palier De Bielle	Lagerdeckel	Tapa Rodamiento
6	11.64607.000	2		Perno motore	Engine pin	Axe moteur	Motorbolzen	Perno motor
7	13.21060.000	2		Dado M10x1,25	Nut M10x1,25	Ecrou M10x1,25	Mutter M10x1,25	Tuerca M10x1,25
8	25.60311.000	2		Piastrina elastica M6	Spring plate M6	Plaqueette é lastique M6	Plät tchen M6	Pletina elástica M6
9	28.85861.000	1		Serratura bloccasterzo	Security lock	Serrure blocage guidon	Lenkradschloss	Cerradura bloqueo manillar
10	11.50010.000	1		Bullone M6x25	Bolt M6x25	Boulon M6x25	Bolzen M6x25	Tornillo M6x25
11	31.64060.000	2		Vite TBCE M8X16	Screw TBCE M8X16	Vis TBCE M8X16	Schraube TBCE M8X16	Tornillo TBCE M8X16
12	15.14264.000	1		Fascetta	Clamp	Collier	Schelle	Abrazadera
13	031.31.033.00.00	1		Tampone anteriore serbatoio	Front buffer tank	Silentbloc AV. ré servoir	Puffer tank	Silent-block del. deposito
15	020.31.034.00.00	1		Adesivo anteriore	Front sticker	Dé calcomanie AV.	Vorderer Kleber	Pega delantero
16	020.31.035.00.00	1		Adesivo posteriore	Rear sticker	Dé calcomanie AR.	Hinterer Kleber	Pega trasero
17	11.54521.000	2		Bullone M8x16	Bolt M8x16	Boulon M8x16	Bolzen M8x16	Tornillo M8x16
18	27.49500.000	1		Rondella 8x18	Washer 8x18	Rondelle 8x18	U.Scheibe 8x18	Arandela 8x18
19	13.17123.000	2		Dado M8 flangiato	Nut M8	Ecrou M8	Mutter M8	Tuerca M8
20	026.31.079.80.00	1		Staffa attacco testa dx.	Head connection bracket R.H.	Bride attelage culasse D.	Befestigung Zylinderkopf R.	Brida anclaje culata der.
21	026.31.078.80.00	1		Staffa attacco testa sx.	Head connection bracket L.H.	Bride attelage culasse G.	Befestigung Zylinderkopf L.	Brida anclaje culata izq.
22	11.55900.000	1		Bullone 8.55 PF CH13 RS	Bolt 8.55 PF CH13 RS	Boulon 8.55 PF CH13 RS	Bolzen 8.55 PF CH13 RS	Tornillo 8.55 PF CH13 RS
23	25.25180.000	2		Passacavo	Grommet	Passe-câ ble	Kabeldurchgang	Pasacables
24	11.47015.000	1		Bullone M6x12	Bolt M6x12	Boulon M6x12	Bolzen M6x12	Tornillo M6x12
25	13.16000.000	2		Dado M8x6	Nut M8x6	Ecrou M8x6	Mutter M8x6	Tuerca M8x6
26	27.33741.000	4		Rivetto	Rivet	Rivet	Niete	Remache
27	27.40500.000	2		Rondella 6x13	Washer 6x13	Rondelle 6x13	U.Scheibe 6x13	Arandela 6x13
28	11.55900.000	1		Bullone 8.55 PF CH13 RS	Bolt 8.55 PF CH13 RS	Boulon 8.55 PF CH13 RS	Bolzen 8.55 PF CH13 RS	Tornillo 8.55 PF CH13 RS
29	27.23473.000	1		Raccordo sfciato olio	Oil breather joint	Raccord ré niflard huile	Entlüftungstutzen	Racor respiradero aceite
30	27.49500.000	1		Rondella	Washer	Rondelle	U.Scheibe	Arandela
31	13.17123.000	1		Dado M8 flangiato	Nut M8	Ecrou M8	Mutter M8	Tuerca M8

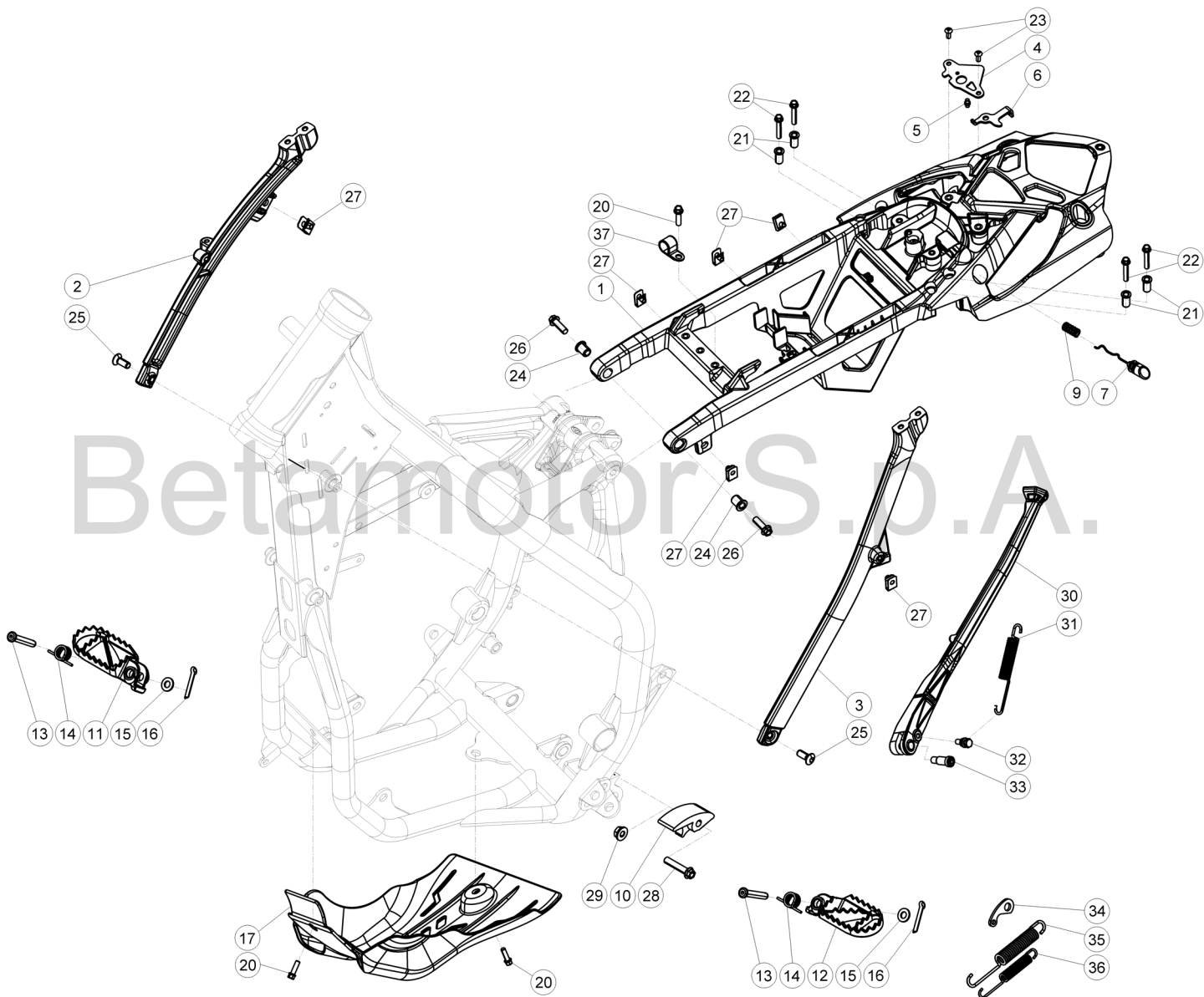

© Copyright 2016 Betamotor S.p.A.



# Tav.32

Pos Loc Pos Ps Pos	Numero Number Numé ro Número Nummer	Q.tà Q.ty Q.té M.ge C.ad	Nota Note Note Nota Anm.	Descrizione	Description	Dé signation	Beschreibung	Descrìpziò n
1	026.32.003.80.51	1		Telaietto posteriore	Rear frame	Châ ssis arriè re	Hinterer kleiner Rahmen	Bastidor trasero
2	020.32.100.00.59	1		Braccetto destro	Right arm	Bras droit	Rechter Schutzblecharm	Brazo derecho
3	020.32.027.42.59	1		Attacco telaio posteriore sx	Rear LH frame fastening	Fixation châ ssis arriè re gauche	Rahmen befestigung hinten links	Enganche bastidor trasero izq.
4	020.32.010.00.05	1		Piastra fissaggio serratura	Lock sec. Plate	Plaque fix. Serrure	Befestigungsplatte Schloß	Chapa fij. cerradura
5	020.32.112.00.00	1		Perno serratura	Pin	Pivot	Zapfen	Perno
6	020.32.011.00.05	1		Piasta ritegno serratura	Plate	Plaquette	Schild	Placa
7	020.32.013.80.51	1		Bottone	Knob	Bouton	Knopf	Boton
9	020.32.016.00.00	1		Molla	Spring	Ressort	Feder	Muelle
10	25.25601.000	1		Pattino catena	Chain shoe	Doigt chaîne	Gleitauflage	Patí n cadena
11	25.32521.000	1		Pedana dx.	Foot-peg R.H.	Repose-pieds d.	Fußblech rechts	Estribo der.
12	25.32531.000	1		Pedana sx.	Foot-peg L.H.	Repose-pieds g.	Fußblech links	Estribo izq.
13	25.54465.000	2		Perno pedana	Footrest pin	Pivot repose-pied	Rasten Pin	Eje estribera
14	016.32.020.00.00	2		Molla pedanina	Foot rest spring	Ressort repose-pied	Fußblechfeder	Muelle estribo
15	031.32.001.00.00	2		Rondella 10x21x2	Washer 10x21x2	Rondelle 10x21x2	U.Scheibe 10x21x2	Arandela 10x21x2
16	12.81993.000	2		Copiglia 3x20	Split pin 3x20	Goupille 3x20	Splint 3x20	Grupilla 3x20
17	036.32.001.00.00	1		Protezione motore	Engine protection	Protection moteur	Motorschutz	Protección motor
20	11.49070.000	3		Bullone 6x20 ch rs	Bolt 6x20 ch rs	Boulon 6x20 ch rs	Bolzen 6x20 ch rs	Tornillo 6x20 ch rs
21	020.32.004.00.00	4		Boccola superiore	Upper bush	Douille supé rieur	Obere Buchse	Casquillo superior
22	11.50355.000	4		Bullone M6x35	Bolt M6x35	Boulon M6x35	Bolzen M6x35	Tornillo M6x35
23	31.29810.000	2		Vite 5x12	Screw 5x12	Vis 5x12	Schraube 5x12	Tornillo 5x12
24	020.32.003.00.00	2		Boccola anteriore	Front bush	Douille avant	Vordere Buchse	Casquillo delantero
25	007.32.032.00.00	2		Vite speciale TSBEI	Special screw TSBEI	Vis spé ciale TSBEI	Spezialschraube TSBEI	Tornillo especial TSBEI
				CH6 M8x20 10.9 zinc	CH6 M8x20 10.9 zinc	CH6 M8x20 10.9 zinc	CH6 M8x20 10.9 zinc	CH6 M8x20 10.9 zinc
26	31.64070.000	2		Vite flangiata 8x30	Flanged screw 8x30	Vis à brides 8x30	Flanschschraube 8x30	Tornillo rebordeado 8x30
27	25.60311.000	6		Piastrina elastica M6	Spring plate M6	Plaquette é lastique M6	Plättchen M6	Pletina elástica M6
28	11.55480.000	1		Vite M8x40	Screw M8x40	Vis M8x40	Schraube M8x40	Tornillo M8x40
29	13.17020.000	1		Dado autoblocc. Basso M8	Nut M8	Ecrou M8	Mutter M8	Tuerca M8
30	031.32.070.00.00	1		Cavalletto	Central stand	Bé quille	Kippständer	Caballate
31	020.32.026.00.00	1		Molla cavalletto	Central stand spring	Ressort bé quille	Feder Kippständer	Muelle caballete
32	11.66615.000	1		Bullone spec. piastra cavalletto	Central stand special bolt	Boulon spec. plaque bé q.	Spezialschraube Kippständerplatte	Tornillo especial chapa caballete
33	11.66614.000	1		Bullone spec. cavalletto	Special bolt	Boulon spec.	Spezialschraube	Tornillo especial
34	25.57636.000	1		Piastrina aggancio molla	Bracket spring	Plaquette accroch. ressort	Plättchen federanlenkung	Placa eng. muelle
35	22.48819.000	1		Molla esterna	Spring	Ressort	Feder	Muelle
36	22.48818.000	1		Molla interna	Spring	Ressort	Feder	Muelle
37	15.14654.000	1		Fascetta	Clamp	Collier	Schelle	Abrazadera

# Tav.33A

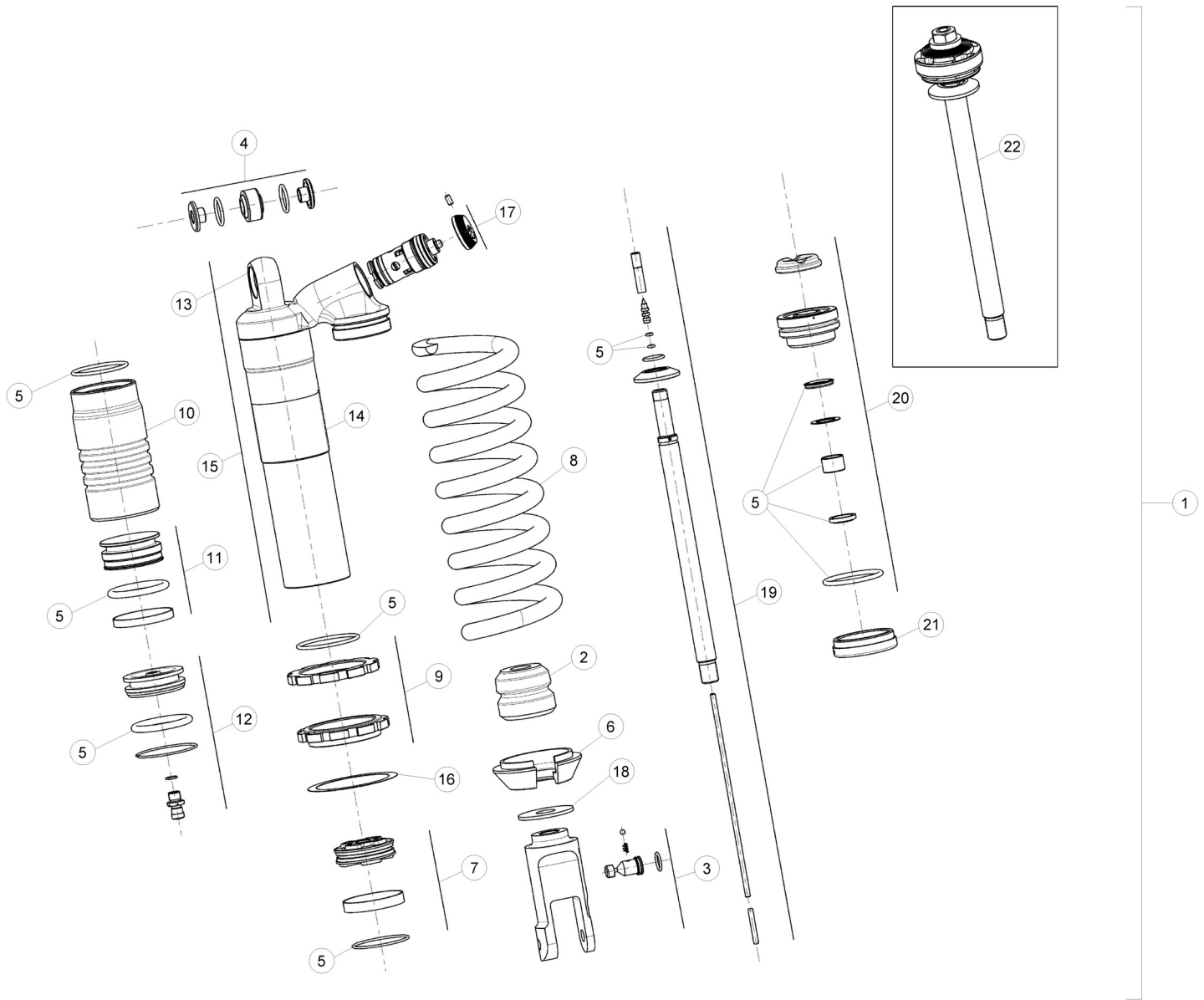

# Tav.33A

Pos Loc Ps Pos	Numero Number Numéro Número Nummer	Q.tà Q.ty Q.té M.ge C.ad	Nota Note Nota Anm.	Descrizione	Description	Dé signation	Beschreibung	Descrìpiò n
1	026.33.006.80.00	1		Ammortizzatore completo	Shock absorber assembly	Amortisseur complet	Stoßdämpfer komplett	Amortiguador completo
2	020.33.141.00.00	1		Tampone	Buffer	Silentbloc	Puffer	Silent-block
3	031.33.006.00.00	1		Gruppo forchetta ammortizz.	Shock absorber inf. Connection	Fixation inférieure amortisseur	Untere Befestigung Stossdämpfer	Fijador inferior amortiguador
4	13.86078.800	1		Kit distanziali ammortizzatore	Damper spacer kit	Jeu entretoises amortisseur	Kit Stoßdämpfer Distanz	Juego distanciador amortiguador
5	031.33.044.00.00	1		Gruppo guarnizioni	Gasket set	Groupe garnitures	Dichtungssatz	Grupo juntas
6	15.39110.000	1		Fondello	Cup	Godet	Deckel	Cazoleta
7	031.33.141.00.00	1		Pistone completo	Piston set	Piston compl.	Kolben, kompl.	Pistón, compl.
8	026.33.002.00.00	1		Molla K 5,4	Spring K 5,4	Ressort K 5,4	Feder K 5,4	Muelle K 5,4
9	031.33.005.00.00	1		Gruppo ghiera	Ring nuts	Douilles	Gewinderingen	Casquillos
10	031.33.007.00.00	1		Serbatoio ammortizzatore	Shock absorber tank	Réervoir de l'amortisseur	Gasbehälter für Stoßdämpfer	Depósito amortiguador
11	031.33.008.00.00	1		Gruppo diaframma	Diaphragm assy	Groupe diaphragme	Biegeplattengruppe	Grupo diafragma
12	031.33.009.00.00	1		Gruppo tappo	Plug assy	Groupe bouchon	Verschlussgruppe Kpl	Grupo tapón
13	031.33.010.00.00	1		Basetta	Bracket	Support	Halter	Soporte
14	031.33.011.00.00	1		Corpo ammortizzatore	Damper body	Corps de l'amortisseur		Cuerpo amortiguador
15	031.33.011.80.00	1		Ammortizzatore completo	Shock absorber assembly	Amortisseur complet	Stoßdämpfer komplett	Amortiguador completo
16	031.33.012.00.00	1		Rosetta	Washer	Rondelle	Federring	Arandela
17	031.33.013.00.00	1		Volantino	Handwheel	Roue a main	Handrad	Rueda de mano
18	031.33.014.00.00	1		Rondella	Washer	Rondelle	U.Scheibe	Arandela
19	031.33.015.00.00	1		Stelo	Stem	Tige	Stange	Varilla
20	031.33.016.00.00	1		Gruppo guida stelo	Guide rod assy	Groupe guide tige	Pumpenstößelgruppe	Grupo guja espiga
21	031.33.017.00.00	1		Gruppo tappo ammortizzatore	Shock-absorber plug assy.	Groupe bouchon amortisseur	Verschlussgruppe Kpl	Grupo tapón amortiguador
22	026.33.004.80.00	1		Stelo completo	Operating rod, assy.	Tige compl.	Kolbenstange, kompl.	Varilla completa

# Tav.33B

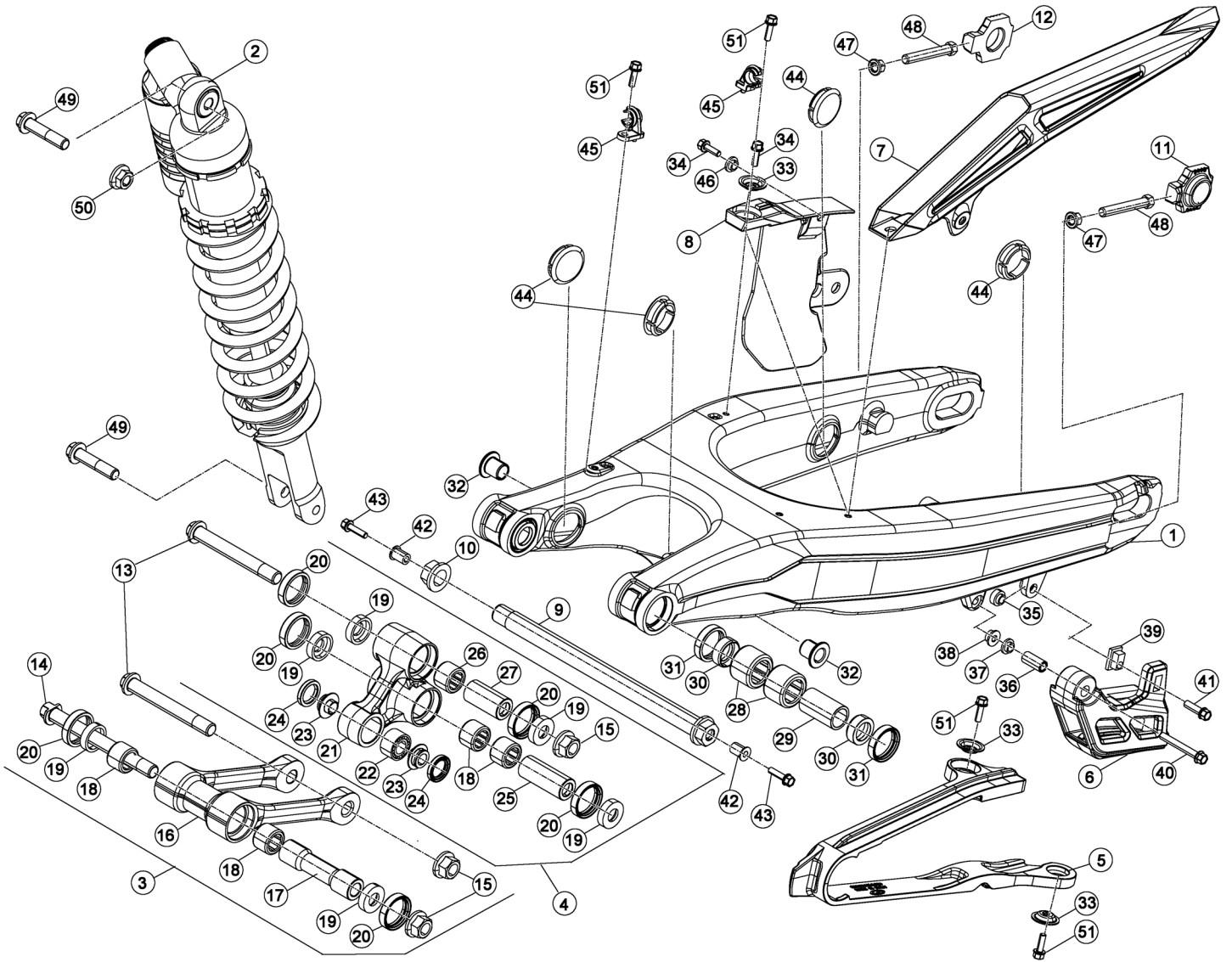

# Tav.33B

Pos Loc Pos Ps Pos	Numero Number Numéro Número Nummer	Q.tà Q.ty Q.té M.ge C.ad	Nota Note Note Nota Anm.	Descrizione	Description	Désignation	Beschreibung	Descripció
1	031.33.019.00.59	1		Forcellone	Big fork	Fourche	Radschwinge	Horquilla
2	026.33.006.80.00	1		Ammortizzatore completo	Shock absorber assembly	Amortisseur complet	Stoßdämpfer komplett	Amortiguador completo
3	020.33.030.80.00	1		Bielletta	Connecting rod	Biellette	Bolzensange	Bieleta
4	020.33.020.80.00	1		Bilanciere	Lever	Balancier	Kipphebel	Balancin
5	020.33.015.00.00	1		Tassello guidacatena super.	Upper sliding block	Chevile guide de chaine sup.	Schwingschleifklotz oben	Protector catena superior
6	29.10071.000	1		Tassello guidacatena infer.	Lower sliding block	Chevile guide de chaine inf.	Schwingschleifklotz unten	Protector catena inferior
7	12.88591.159	1		Copricatena superiore	Up. Chain cover	Couvre-chaîne superieur	Kettenschutz oben	Cubrecadena superior
8	12.88594.159	1		Copricatena inferiore	Lower chain cover	Couvre-chaîne inferieur	Kettenschutz unten	Cubrecadena inferior
9	25.47652.000	1		Perno forcellone	Swingarm pivot	Axe fourche AR.	Schwingbolzen	Eje basculante
10	13.27121.000	1		Dado speciale	Special nut	Ecrou spé ciale	Spezialmutter	Tuerca especial
11	29.11866.100	1		Tendicatena SX	Chain adjuster L.	Tendeur de chaine G.	Kettenspanne L.	Tensor de cadena l.
12	29.11865.100	1		Tendicatena DX	Chain adjuster R.	Tendeur de chaine D.	Kettenspanner R.	Tensor de cadena D.
13	11.63992.000	2		Vite speciale M12	Special screw M12	Vis spé ciale M12	Spezialschraube M12	Tornillo especial M12
14	020.33.032.00.00	1		Vite speciale M12	Special screw M12	Vis spé ciale M12	Spezialschraube M12	Tornillo especial M12
15	13.21130.000	3		Dado autobloccante M12	Self locking nut M12	Ecrou de sécurité M12	Mutter, selbstsichernd M12	Tuerca de seguridad M12
16	020.33.030.00.00	1		Bielletta	Connecting rod	Biellette	Bolzensange	Bieleta
17	020.33.031.00.00	1		Distanziale	Spacer	Entretoise	Distanzstück	Distanciadador
18	11.22055.000	4		Boccola a rulli 20x26x16	Roller bearing 20x26x16	Douille à roulements 20x26x16	Rollenbuchse 20x26x16	Caja de grasa de rodillos 20x26x16
19	28.14083.000	6		Scodellino	Stop washer	Rondelle d' ar	Federaufnahme	Platillo
20	10.64481.000	6		Paraolio	Oil seal	Pare-huile	Dichtring	Sello de lub.
21	020.33.020.00.00	1		Bilanciere	Lever	Balancier	Kipphebel	Balancin
22	16.17310.000	1		Boccola a rulli 12x24x30	Roller bearing 12x24x30	Douille à roulements 12x24x30	Rollenbuchse 12x24x30	Caja de grasa de rodillos 12x24x30
23	11.21920.000	2		Boccola	Bush	Moyeu	Büchse	Buje
24	10.56020.000	2		Paraolio 16x24x4	Oil seal 16x24x4	Pare-huile 16x24x4	Dichtring 16x24x4	Sello de lub. 16x24x4
25	13.62813.000	1		Distanziale 12x20x50	Spacer 12x20x50	Entretoise 12x20x50	Distanzstück 12x20x50	Distanciadador 12x20x50
26	11.22061.000	1		Boccola a rulli 20x26x30	Roller bearing 20x26x30	Douille à roulements 20x26x30	Rollenbuchse 20x26x30	Caja de grasa de rodillos 20x26x30
27	13.62812.000	1		Distanziale 12x20x40	Spacer 12x20x40	Entretoise 12x20x40	Distanzstück 12x20x40	Distanciadador 12x20x40
28	11.22056.000	4		Boccola a rullini 22x28x12	Roller cage 22x28x12	Cage Aiguille 22x28x12	Rollenkäfig 22x28x12	Jaula rodillos 22x28x12
29	13.49183.000	2		Distanziale forcellone	Big fork spacer	Entretoise fourche	Distanzstück Radschwinge	Distanciadador horquilla
30	28.14081.000	4		Scodellino	Stop washer	Rondelle d' ar	Federaufnahme	Platillo
31	10.64481.000	4		Paraolio	Oil seal	Pare-huile	Dichtring	Sello de lub.
32	020.33.001.00.00	2		Boccola	Bush	Moyeu	Büchse	Buje
33	27.74786.000	3		Rondella bombata	Kasher	Rondelle	Scheibe	Arandela
34	11.46360.000	2		Bullone flangiato M5x16	Head Flanged bolt M5x16	Boulon Bridé M5x16	Bundbolzen M5x16	Bulón con Brida M5x16
35	13.12610.000	1		Dado	Nut	Ecrou	Mutter	Tuerca
36	13.49191.000	1		Distanziale	Spacer	Entretoise	Distanzstück	Distanciadador
37	13.54820.000	1		Distanziale 6,5x9,0x13,5	Spacer 6,5x9,0x13,5	Entretoise 6,5x9,0x13,5	Distanzstück 6,5x9,0x13,5	Distanciadador 6,5x9,0x13,5
38	13.13020.000	1		Dado autobloccante M6	Self locking nut M6	Ecrou de sécurité M6	Mutter, selbstsichernd M6	Tuerca de seguridad M6
39	13.48868.000	1		Distanziale tassello guidacatena	Sliding block spacer	Entretoise chevile guide de chaine	Abstandstück Schwingschleifklotz	Separador protector cadena/basculante
40	11.05535.000	1		Bullone 6.50 rs ch 8	Bolt 6.50 rs ch 8	Boulon 6.50 rs ch 8	Bolzen 6.50 rs ch 8	Tornillo 6.50 rs ch 8
41	11.49070.000	1		Bullone 6x20 ch rs	Bolt 6x20 ch rs	Boulon 6x20 ch rs	Bolzen 6x20 ch rs	Tornillo 6x20 ch rs
42	27.33740.000	2		Rivetto filettato M6	Threaded rivet M6	Rivet fileté M6	Niete mit gewinde M6	Remache roscado M6
43	11.46401.000	2		Bullone M5x20	Bolt M5x20	Boulon M5x20	Bolzen M5x20	Tornillo M5x20
44	29.10596.136	4		Tappo forcellone D30	Big fork plug D30	Bouchon fourche D30	Radschwinge verschluß D30	Tapón horquilla D30
45	15.14605.000	2		Passatubo	Grommet	Passe-tube	Rohrdurchgang	Pasa-tubo
46	13.54820.000	1		Distanziale 6,5x9,0x13,5	Spacer 6,5x9,0x13,5	Entretoise 6,5x9,0x13,5	Distanzstück 6,5x9,0x13,5	Distanciadador 6,5x9,0x13,5
47	13.17122.000	2		Dado flangiato M8 CH13	Flanged nut M8 CH13	Ecrou bordé M8 CH13	Flanschmutter M8 CH13	Tuerca embridada M8 CH13
48	11.55909.000	2		Bullone M8x55	Bolt M8x55	Boulon M8x55	Bolzen M8x55	Tornillo M8x55
49	11.62050.000	2		Bullone fiss. ammortizzatore M10x45	Damper sec. bolt M10x45	Boulon fix. amortisseur M10x45	Befestigungsbolzen M10x45	Tornillo fij amortiguador M10x45
50	13.21050.000	1		Dado flangiato M10X1,25	Flanged nut M10X1,25	Ecrou bordé M10X1,25	Flanschmutter M10X1,25	Tuerca embridada M10X1,25
51	11.46251.000	4		Bullone flangiato M5x12	Head Flanged bolt M5x12	Boulon Bridé M5x12	Bundbolzen M5x12	Bulón con Brida M5x12



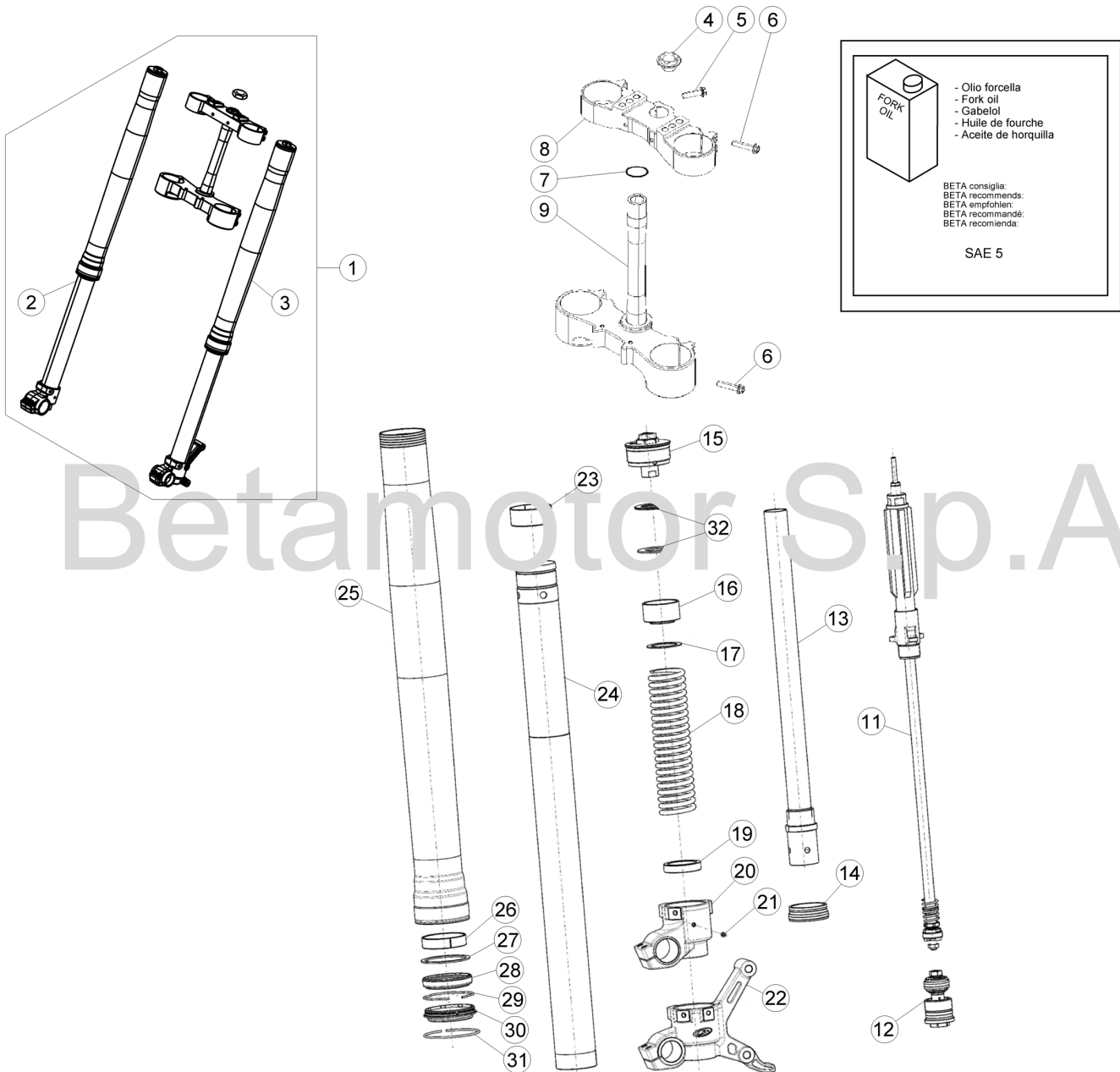

© Copyright 2016 Betamotor S.p.A.



# Tav.34

Pos Loc Pos Ps Pos	Numero Number Numé ro Número Nummer	Q.tà Q.ty Q.té M.ge C.ad	Nota Note Note Nota Anm.	Descrizione	Description	Dé signation	Beschreibung	Descrìpziò n
1	026.34.021.80.00	1		Forcella	Fork	Fourche	Gabel	Horquilla
2	026.34.023.80.61	1		Gamba Dx	RH leg	Tube D.	Rechte Beineinheit	Pata derecha
3	026.34.022.80.61	1		Gamba Sx	LH leg	Tube G.	Linke Beineinheit	Pata izquierda
4	020.34.004.00.00	1		Dado 20X1,5	Nut 20X1,5	Ecrou 20X1,5	Mutter 20X1,5	Tuerca 20X1,5
5	11.55440.000	1		Bullone 8x30 ch10 rs	Bolt 8x30 ch10 rs	Boulon 8x30 ch10 rs	Bolzen 8x30 ch10 rs	Tornillo 8x30 ch10 rs
6	11.55510.000	8		Bullone M8x40	Bolt M8x40	Boulon M8x40	Bolzen M8x40	Tornillo M8x40
7	10.66420.000	1		Anello OR 20,22,3,53 NBR	O-Ring 20,22,3,53 NBR	Bague d' é tanché ité 20,22,3,53 NBR	O-Ring 20,22,3,53 NBR	Anillo OR 20,22,3,53 NBR
8	026.34.024.42.59	1		Piastra di sterzo superiore	Steering head	Tête de direction	Gabelkopf	Tija superior
9	026.34.025.80.59	1		Piastra di sterzo inferiore	Steering crown with pin	Socle de direction avec pivot	Untere Gabelbrücke mit Bolzen	Base de direcció n con perno
11	026.34.360.00.00	2		Gruppo compressione	Compression unit	Groupe compression	Druckstufengruppe	Grupo compresió n
12	026.34.359.00.00	2		Gruppo estensione	Rebound unit	Ecrou groupe dé tente	Zugstufengruppe	Grupo rebote
13	026.34.017.00.00	2		Tube interno	Inner tube	Tube inté rieur	Gabel Innenrohr	Tube interior
14	020.34.313.00.00	2		Anello appoggio stelo + O-Ring	Stem supporting ring + O-Ring	Anneau appui tige + O-Ring	Anlagering für stange + O-Ring	Anillo de apoyo varilla + O-Ring
15	031.34.022.00.00	2		Gruppo tappo	Plug assy	Groupe bouchon	Verschlussgruppe Kpl	Grupo tapó n
16	026.34.358.00.00	2		Distanziale in nylon	Nylon spacer	Entretoise en nylon	Nylon-Distanzstück	Separador de nylon
17	031.34.323.00.00	2		Rosetta	Washer	Rondelle	Federring	Arandela
18	020.34.332.00.00	2		Kit molle 4,2K	Springs kit 4,2K	Gr. ressorts 4,2K	Federset 4,2K	Kit muelles 4,2K
19	031.34.026.00.00	2		Anello centraggio	Centering ring	Bague de centrage	Zentrierring	Anillo de centrage
20	020.34.331.00.00	1		Piedino dx forcella	R.H. fork foot	Pied de fourche droit	Gabelfuß rechts	Pata horquilla der.
21	020.34.308.00.00	2		Grano	Dowel	Goujon	Stift	Clavija
22	020.34.311.00.00	1		Piedino sx forcella	L.H. fork foot	Pied de fourche gauche	Gabelfuß links	Pata horquilla izq.
23	020.34.320.00.00	2		Boccola Ø49/47 L 20	Bush Ø49/47 L 20	Moyeu Ø49/47 L 20	Büchse Ø49/47 L 20	Buje Ø49/47 L 20
24	031.34.021.00.00	2		Stelo	Stem	Tige	Stange	Varilla
25	026.34.009.00.00	2		Fodero	Sleeve	Protection	Schutzstück	Protecció n
26	031.34.020.00.00	2		Boccola ø52/48 L15	Bush ø52/48 L15	Moyeu ø52/48 L15	Büchse ø52/48 L15	Buje ø52/48 L15
27	020.34.318.00.00	2		Distanziale	Spacer	Entretoise	Distanzstück	Distanciador
28	020.34.317.00.00	2		Guarnizione	Packing	Joint	Dichtung	Junta
29	020.34.316.00.00	2		Seeger Ø58,45	Circlip Ø58,45	Circlip Ø58,45	Seeger Ø58,45	Seeger Ø58,45
30	020.34.315.00.00	2		Raschiapolvere	Dust scraper	Graffe poussiere	Staubabstreifer	Esc. polvo
31	020.34.314.00.00	2		Seeger Ø64,5 Ø2	Circlip Ø64,5 Ø2	Circlip Ø64,5 Ø2	Seeger Ø64,5 Ø2	Seeger Ø64,5 Ø2
32	031.34.023.00.00	2		Svincolo molla	Anti-friction spring	Anti-friction pour ressort	Anti-Reibungsfeder	Antifricció n muelle

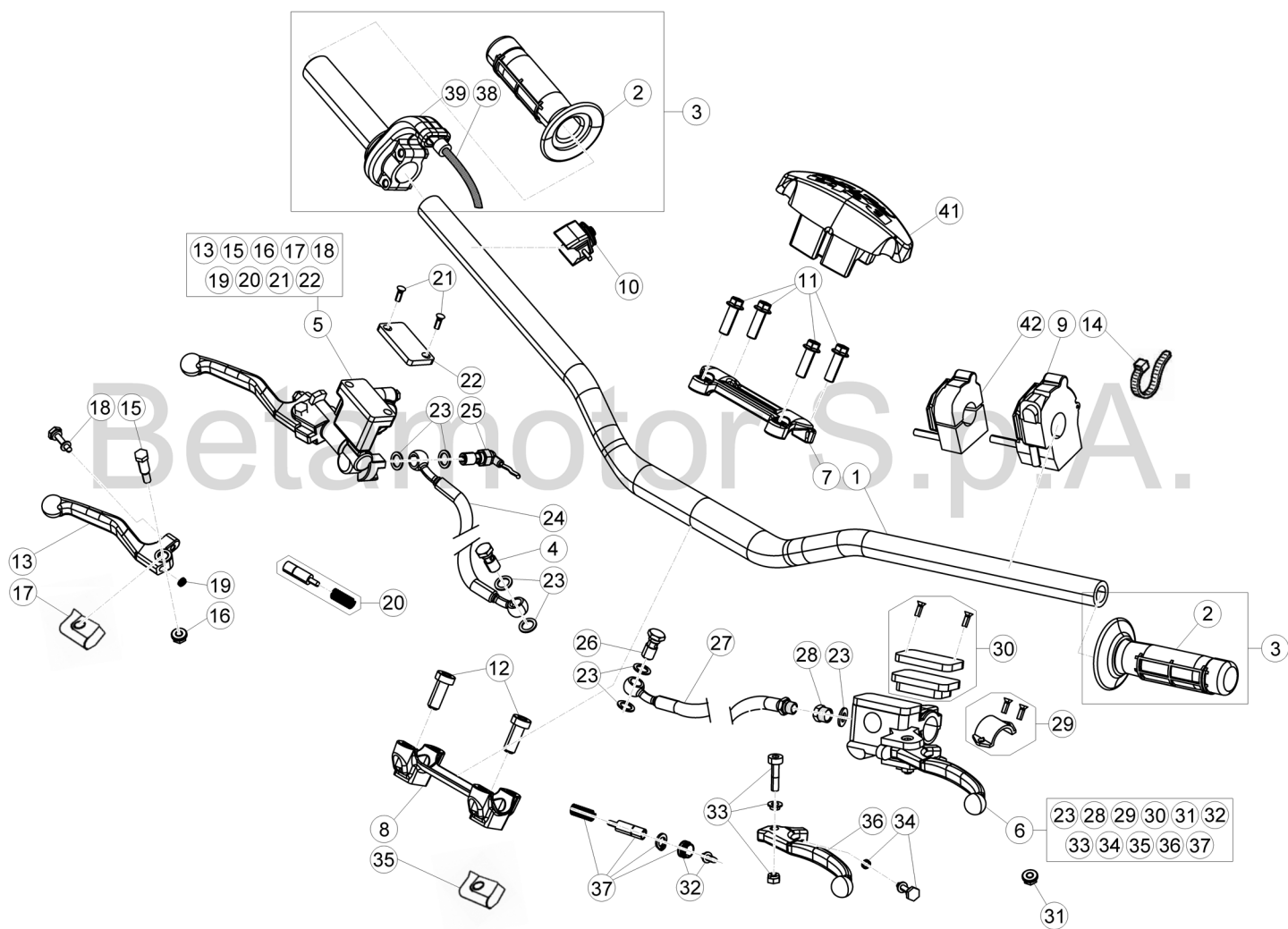

© Copyright 2016 Betamotor S.p.A.

# Tav.35

Pos Loc Ps Pos	Numero Number Numé ro Nú mero Nummer	Q.tà Q.ty Q.té M.ge C.ad	Nota Note Note Nota Anm.	Descrizione	Description	Dé signation	Beschreibung	Descrì cì o n
1	026.35.000.00.59	1		Manubrio	Handlebars	Guidon	Lenker	Manillar
2	036.35.005.00.00	1		Coppia manopole	Grips (couple)	Poigné es (couple)	Handgriffpaar	Manecilla (juego)
3	026.35.002.80.00	1		Comando gas completo	Throttle control compl.	Commande gaz compl.	Gasgriff kpl.	Accionamiento acelerador co
4	11.65053.000	1		Bullone forato 10x1,25	Pierced bolt 10x1,25	Boulon avec trou 10x1,25	Bolzen 10x1,25	Tornillo 10x1,25
5	21.02057.059	1		Leva freno ant.	Fr. br. lever	Lev. fr. AV.	Vorderradbremshebel	Pal. fr. del.
6	020.35.020.00.00	1		Leva comando frizione	Clutch control lever	Levier de commande embrayage	Kupplungshebel	Palanca mando embrague
7	12.08253.000	1		Cavallotto superiore	Upper u bolt	Etrier sup.	Obere Brü cke	Brida sup.
8	12.08263.000	1		Cavallotto inferiore	Lower u bolt	Etrier infé rieur	Untere Brü cke	Brida inferior
9	13.06506.000	1		Commutatore luci	Lights switch	Commutateur feux	Lichtschalter	Conmutador luces
10	18.84981.000	1		Interruttore avviamento	Starter switch	Commutateur demarrage	Anlasschalter	Interruptor de arranque
11	31.64070.000	4		Vite flangiata 8x30	Flanged screw 8x30	Vis à brides 8x30	Flanschschraube 8x30	Tornillo rebordeado 8x30
12	31.65626.000	2		Vite a brugola M10 25	Allen screw M10 25	Vis à 6 pans M10 25	Sechskantschraube M10 25	Tornillo a llave allen M10 25
13	21.27104.000	1		Leva freno	Brake lever	Levier du frein	Bremshebel	Palanca de freno
14	15.14264.000	3		Fascetta	Clamp	Collier	Schelle	Abrazadera
15	31.96832.000	1		Perno leva freno	Brake lever pin	Goujon levier frein	Bremshebelstift	Perno leva freno
16	13.30911.000	1		Dado	Nut	Ecrou	Mutter	Tuerca
17	16.33841.000	1		Coprileva	Lever cover	Couvre levier	Hebeldeckel	Cubre-palanca
18	31.88604.000	1		Vite regol. leva	Adjusting screw	Vis régl age	Einstellschrauben	Tornillo reg.
19	22.38704.000	1		Molla registro leva freno ant.	Front brake lever adjust spring	Ressort enregistrement levier	Regelfeder vorderradbremse	Muelle regul. bomba freno
20	20.08258.000	1		Pistoncino completo pompa	Piston assy, pump	Piston compl. pompe	Kolben kplt. Pumpe	Piston completo bomba
21	31.23410.052	2		Vite fiss. coperchio	Cover sec. screw	Vis de fix. couvercle	Schraube	Tornillo
22	031.36.003.82.00	1		Coperchio serbatoio olio	Oil filler cover	Couvercle ré servoir huile	Ölverschlußdeckel	Tapa depó sito aceite
23	16.50510.000	7		Guarnizione 10x15x1 in rame	Gasket 10x15x1 copper	Joint 10x15x1 cuivre	Dichtung 10x15x1 Kupfer	Junta 10.15.1 (cobre)
24	29.09108.000	1		Tubo Freno Ant.	Front brake tube	Tuyau du frein AV.	Vordere Bremsleitung	Tubo freno delantero
25	18.89621.000	1		Interruttore stop	Stop switch	Interrupteur stop	Stopschalter	Interruptor stop
26	11.65040.000	1		Bullone forato 10x1 x tubo freno	Special bolt	Boulon 10x1 x tube frein	Hohlschraube F.Bremse	Tornillo esp. talad.10.1
27	026.35.001.00.00	1		Tubo frizione	Clutch tube	Canalisation embrague	Kupplungsrohr	Tubo embrague
28	020.35.032.00.00	1		Raccordo	Joint.p.	Raccord	Stützen	Racor
29	020.35.025.00.00	1		Cavallotto	U bolt	Etrier	Brü cke	Brida
30	020.35.023.00.00	1		Tappo serbatoio pompa	Master cyl. tank plug	Bouchon ré servoir maî tre cylindre	Behä lterverschluß Hauptbremszylinder	Tapó n depó sito bomba freno
31	020.35.028.00.00	1		Antiemulsione	Antiemulsion	Antiemulsion	Eulsionswidriger	Antiemulsion
32	020.35.029.00.00	1		Puntalino leva pompa	Push piece	Piece de pression	Druckstü ck	Varilla de presió n
33	020.35.024.00.00	1		Perno leva	Lever pin	Goujon levier	Hebelstift	Perno palanca
34	020.35.030.00.00	1		Guidamolla	Spring guide	Guide ressort	Federfü h rung	Guia resorte
35	020.35.027.00.00	1		Gomma protezione leva	Lever protection grommet	Caoutchouc protection levier	Gummi Hebelerschutz	Goma protecció n palanca
36	020.35.022.00.00	1		Leva frizione nuda	Clutch lever, only	Levier d' embrayage nue	Kupplungshebel	Palanca embrague
37	020.35.026.00.00	1		Kit pistoncino pompa	Piston kit master cyl.	Kit piston. maî tre cyl.	Kolbensatz hauptbremszylinder	Kit pistó n bomba
38	026.35.011.00.00	1		Cavo comando gas	Throttle cable transmission	Transmission commande gaz	Bowdenzü g gasgriff	Transmisió n mando gas
39	026.35.010.00.00	1		Comando gas	Throttle control	Commande gaz	Gasdrehgriff	Mando gas
40	031.35.001.00.00	1		Protezione manubrio	Handlebar protection	Protection guidon	Lenkerschutz	Protecció n manillar
42	031.40.003.00.00	1		Dispositivo switch mappa CDI	Switch for double map CDI	Selecteur mappe CDI	Mappingschalter CDI	Conmutador para cambiar el



- Olio freni  
 - Brake fluid  
 - Bremsflüssigkeit  
 - Liquide de frein  
 - El líquido de frenos

BETA consiglia:  
 BETA recommends:  
 BETA empfiehlt:  
 BETA recommande:  
 BETA recomienda:

**BRAKE FLUID DOT 4**  
**BRAKE FLUID DOT 5.1**

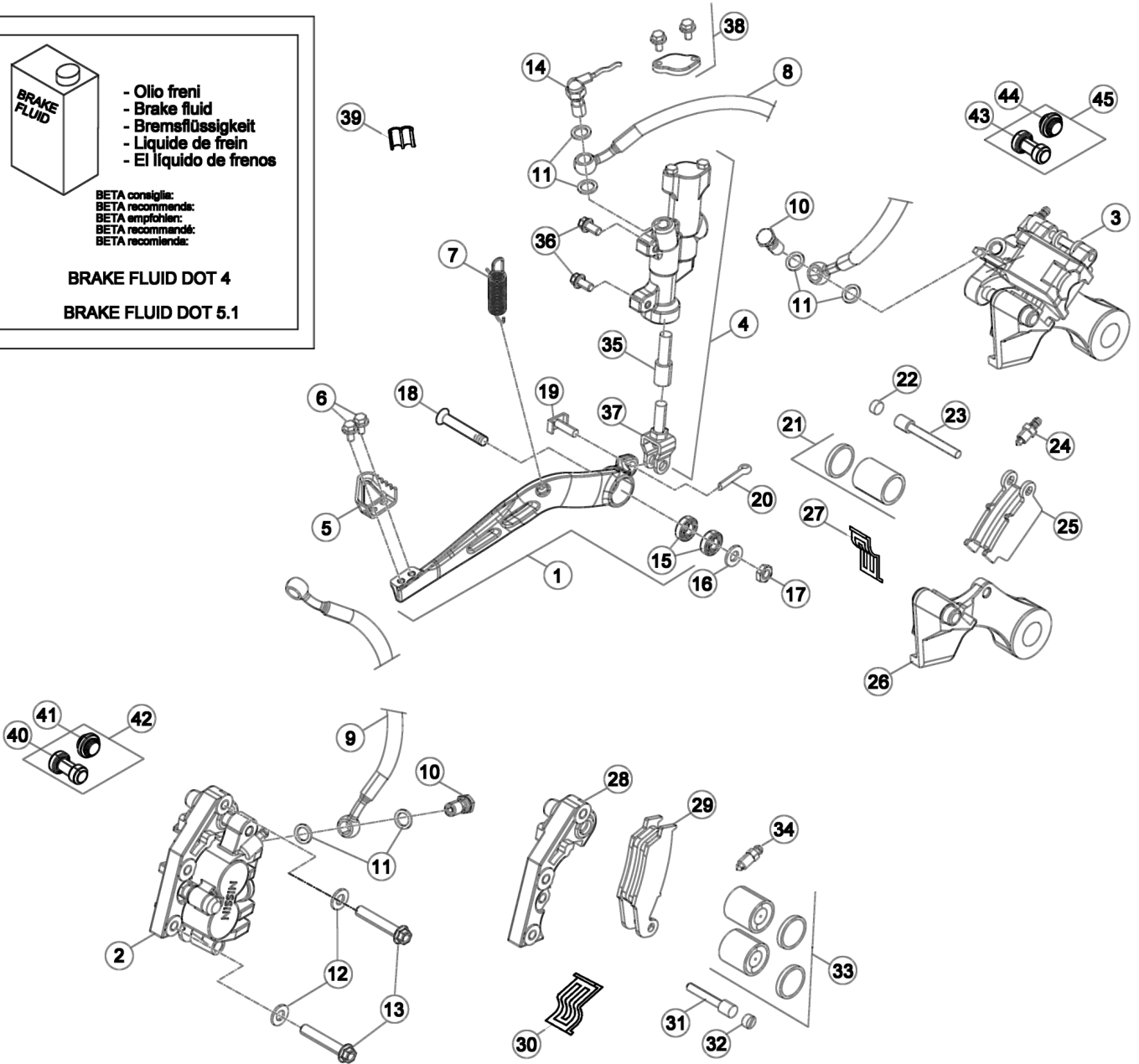

# Tav.36

Pos Loc Pos Ps Pos	Numero Number Numéro Nummer	Q.tà Q.ty Q.té M.ge C.ad	Nota Note Nota Anm.	Descrizione	Description	Dé signation	Beschreibung	Descrìpziò n
1	020.36.001.80.00	1		Pedale freno	Brake pedal	Pé dale frein	Fussbremspedal	Pedal freno
2	25.03056.000	1		Pinza freno anteriore	Front disk brake caliper	Etrier de frein AV.	Bremszange-Scheibe	Pinza freno del.
3	25.03066.000	1		Pinza freno posteriore	Rear disk brake caliper	Etrier de frein AR.	Bremszange	Pinza del freno tras.
4	25.91178.000	1		Pompa freno posteriore	Rear brake cylinder	Maî tre cylindre frein ar.	Hauptbremszylinder Hinterradbremse	Bomba freno trasero
5	22.90053.000	1		Mozzetto	Hub	Moyeu	Nabe	Cubo
6	11.46251.000	2		Bullone flangiato M5x12	Head Flanged bolt M5x12	Boulon Bridé M5x12	Bundbolzen M5x12	Bulón con Brida M5x12
7	026.36.000.00.00	1		Molla ritorno pedale freno	Return brake pedal spring	Ressort de retour frein	Bremspedal Feder	Muelle retorno palanca freno
8	29.09428.000	1		Tube Freno Posteriore	Rear brake tube	Tuyau du frein AR.	Hintere Bremsleitung	Tube freno trasero
9	29.09108.000	1		Tube Freno Ant.	Front brake tube	Tuyau du frein AV.	Vordere Bremsleitung	Tube freno delantero
10	11.65053.000	2		Bullone forato 10x1,25	Pierced bolt 10x1,25	Boulon avec trou 10x1,25	Bolzen 10x1,25	Tornillo 10x1,25
11	16.50510.000	6		Guarnizione 10x15x1 in rame	Gasket 10x15x1 copper	Joint 10x15x1 cuivre	Dichtung 10x15x1 Kupfer	Junta 10.15.1 (cobre)
12	27.49500.000	2		Rondella 8x18	Washer 8x18	Rondelle 8x18	U.Scheibe 8x18	Arandela 8x18
13	11.55690.000	2		Bullone M8x45 ch10 rs	Bolt M8x45 ch10 rs	Boulon M8x45 ch10 rs	Bolzen M8x45 ch10 rs	Tornillo M8x45 ch10 rs
14	18.89621.000	1		Interruttore stop	Stop switch	Interrupteur stop	Stopschalter	Interruptor stop
15	12.93388.000	2		Cuscinetto 8x22x7	Bearing 8x22x7	Roulement 8x22x7	Lager 8x22x7	Cojinete 8x22x7
16	27.49500.000	1		Rondella 8x18	Washer 8x18	Rondelle 8x18	U.Scheibe 8x18	Arandela 8x18
17	13.17020.000	1		Dado autoblocc. Basso M8	Nut M8	Ecrou M8	Mutter M8	Tuerca M8
18	31.63985.000	1		Vite TSPCE 8.50 CL 10.9	Screw TSPCE 8.50 CL 10.9	Vis TSPCE 8.50 CL 10.9	Schraube TSPCE 8.50 CL 10.9	Tornillo TSPCE 8.50 CL 10.9
19	25.41830.000	1		Forcellino	Clip	Ressort	Fixiergabel	Horquilla
20	12.81995.000	1		Copiglia 2x15	Split pin 2x15	Goupille 2x15	Splint 2x15	Grupilla 2x15
21	20.02717.000	1		Kit pistoncini e guarniz. Pinza	Piston e oil seal for pliers	Jeu petit pistons et joint pinces	Reparatursatz Bremszange	Juego piston y guarnicion pinza
22	31.96821.000	1		Grano	Dowel	Goujon	Stift	Clavija
23	25.41860.000	1		Perno ancoraggio pastiglia	Pin hanger	Pivot ancrage	Halter brehsbelage	Varilla esp. Pastillas pinzas
24	28.91002.000	1		Sfiato	Breather	Reniflard	Entlüfter	Respiradero
25	25.25362.000	1		Pastiglie freno post.	Rear brake pads	Pastill. de freins AR.	Hinterbremsbelag	Pastillas frenos tras.
26	020.36.011.00.00	1		Staffa supporto pinza	Caliper support bracket	Bride support étrier	Bremsattelbefestigung	Brida soporte pinza
27	22.32208.000	1		Molla ferma pastiglie pinza	Brake pads spring for pliers	Ressort arret plaquettes	Haltefeder	Muelle pastillas pinza
28	020.36.012.00.00	1		Staffa supporto pinza	Caliper support bracket	Bride support étrier	Bremsattelbefestigung	Brida soporte pinza
29	25.25361.000	1		Pastiglie freno ant.	Front brake pads	Pastill. de freins AV.	Vorderbremsbelag	Pastillas frenos del.
30	22.32207.000	1		Molla ferma pastiglie pinza	Brake pads spring for pliers	Ressort arret plaquettes	Haltefeder	Muelle pastillas pinza
31	25.41859.000	1		Perno ancoraggio pastiglia	Pin hanger	Pivot ancrage	Halter brehsbelage	Varilla esp. Pastillas pinzas
32	31.96821.000	1		Grano	Dowel	Goujon	Stift	Clavija
33	20.02716.000	1		Kit pistoncini e guarniz. Pinza	Piston e oil seal for pliers	Jeu petit pistons et joint pinces	Reparatursatz Bremszange	Juego piston y guarnicion pinza
34	28.91001.000	1		Sfiato	Breather	Reniflard	Entlüfter	Respiradero
35	20.08276.000	1		Kit pistoncino pompa post.	Piston kit rear master cyl.	Kit piston. maî tre cyl. AR.	Kolbensatz hinterhauptbremszylinder	Kit pistón bomba tras.
36	31.30750.000	2		Vite M6x16	Screw M6x16	Vis M6x16	Schraube M6x16	Tornillo M6x16
37	20.08277.000	2		Kit leva	lever kit	Jeu levier	Hebelsatz	Juego palanca
38	20.08275.000	1		Kit serbatoio pompa	Kit, pump tank	Kit reservoir pompe	Deckel pumpstange	Kit deposito bomba
39	25.24442.000	1		Passacavo 6/8	Fair lead 6/8	Passe-fils 6/8	Kabelführung 6/8	Pasa-cable 6/8
40	036.36.002.00.00	1		Protezione	Protection	Protection	Schutzstü ck	Protección
41	036.36.003.00.00	1		Protezione	Protection	Protection	Schutzstü ck	Protección
42	036.36.006.82.00	1		Kit protezioni anteriore	Font protections kit	Jeu protections avant	Kit Vorne Schutzstü ck	Juego protecció nes delanteras
43	036.36.004.00.00	1		Protezione	Protection	Protection	Schutzstü ck	Protección
44	036.36.005.00.00	1		Protezione	Protection	Protection	Schutzstü ck	Protección
45	036.36.007.82.00	1		Kit protezioni posteriore	Rear protections kit	Jeu protections arrière	Kit Hintere Schutzstü ck	Juego protecció nes traseras

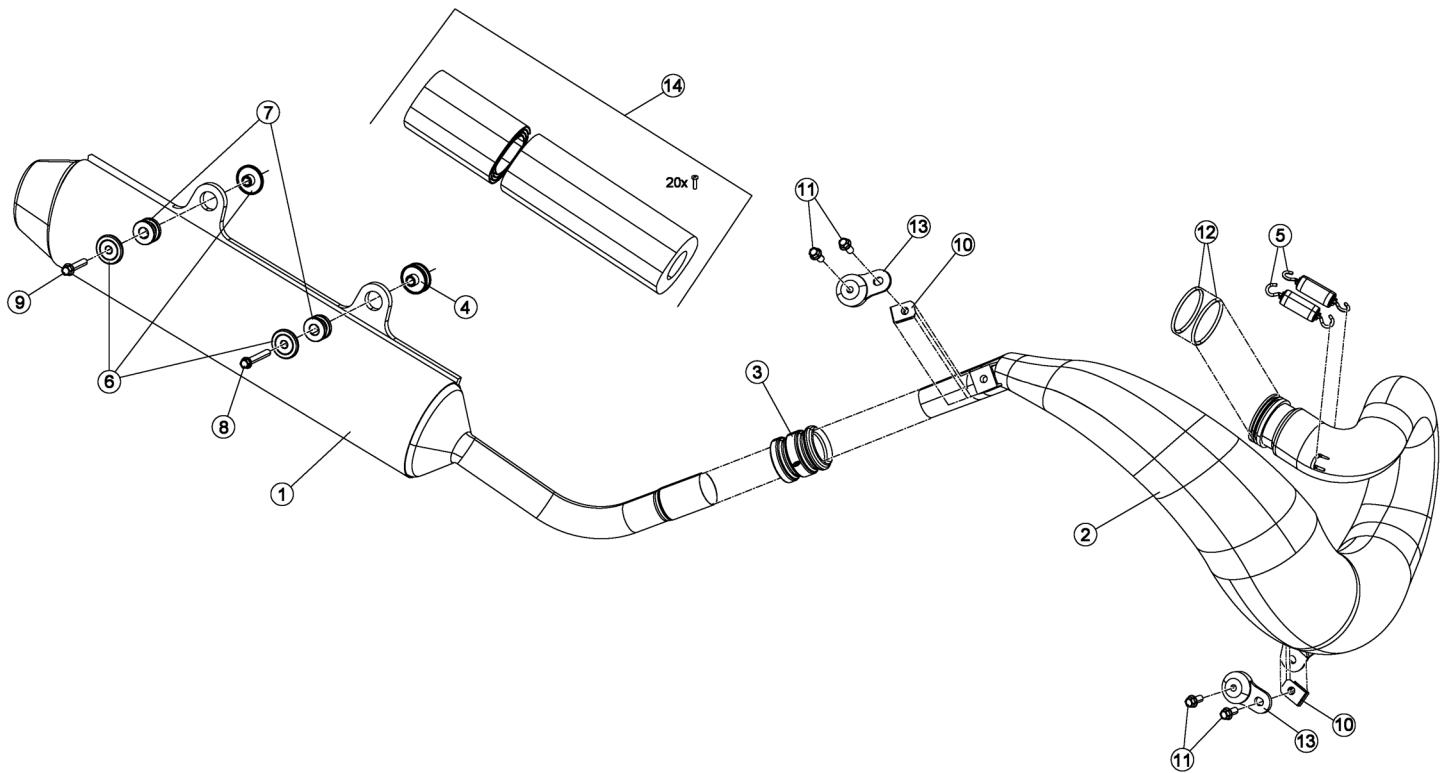

Pos Loc Pos Ps Pos	Numero Number Numéro Número Nummer	Q.tà Q.ty Q.té M.ge C.ad	Nota Note Note Nota Anm.	Descrizione	Description	Dé signation	Beschreibung	Descrisción
1	026.37.014.80.00	1	250cc	Silenziatore completo	Silencer complete	Silencieux complet	Endschalldämpfer	Silenciador completo
1	026.37.015.80.00	1	300cc	Silenziatore completo	Silencer complete	Silencieux complet	Endschalldämpfer	Silenciador completo
2	026.37.002.80.00	1		Collettore di scarico	Exhaust manifold	Collecteur d' échapp.	Abgaskrümmmer	Colector de escape
3	026.37.103.00.00	1		Guarnizione marmitta	Exhaust gasket	Joint pot d' echappement	Dichtung	Goma silenciador
4	026.37.004.00.00	1		Distanziale	Spacer	Entretoise	Distanzstück	Distanciador
5	026.37.005.00.00	2		Molla tubo di scarico	Exhaust pipe spring	Ressort tuyau echapp.	Krummerfeder	Muelle tubo de escape
6	026.37.006.00.00	3		Distanziale	Spacer	Entretoise	Distanzstück	Distanciador
7	28.91946.000	2		Silentbloc	Silentbloc	Silentbloc	Puffer	Silent-block
8	11.50360.000	1		Bullone M6x40	Bolt M6x40	Boulon M6x40	Bolzen M6x40	Tornillo M6x40
9	11.50300.000	1		Bullone 6x30 ch rs	Bolt 6x30 ch rs	Boulon 6x30 ch rs	Bolzen 6x30 ch rs	Tornillo 6x30 ch rs
10	25.60311.000	2		Piastrina elastica M6	Spring plate M6	Plaquette élastique M6	Plättchen M6	Pletina elástica M6
11	11.48025.000	4		Bullone M6x16	Bolt M6x16	Boulon M6x16	Bolzen M6x16	Tornillo M6x16
12	10.66930.000	2		Anello OR	O-Ring	Bague d' é tanché ité	O-Ring	Anillo OR
13	28.91943.000	2		Silent block marmitta	Silencer puffer	Silent block silencieux	Silent block Auspuff	Silent block escape
14	026.37.007.82.00	1		Kit revisione silenziatore	Kit for silencer overhauling	Kit ré v. Silencieux	Reparatursatz Schalldämpfer	Kit revisión silenciador



# Tav.38

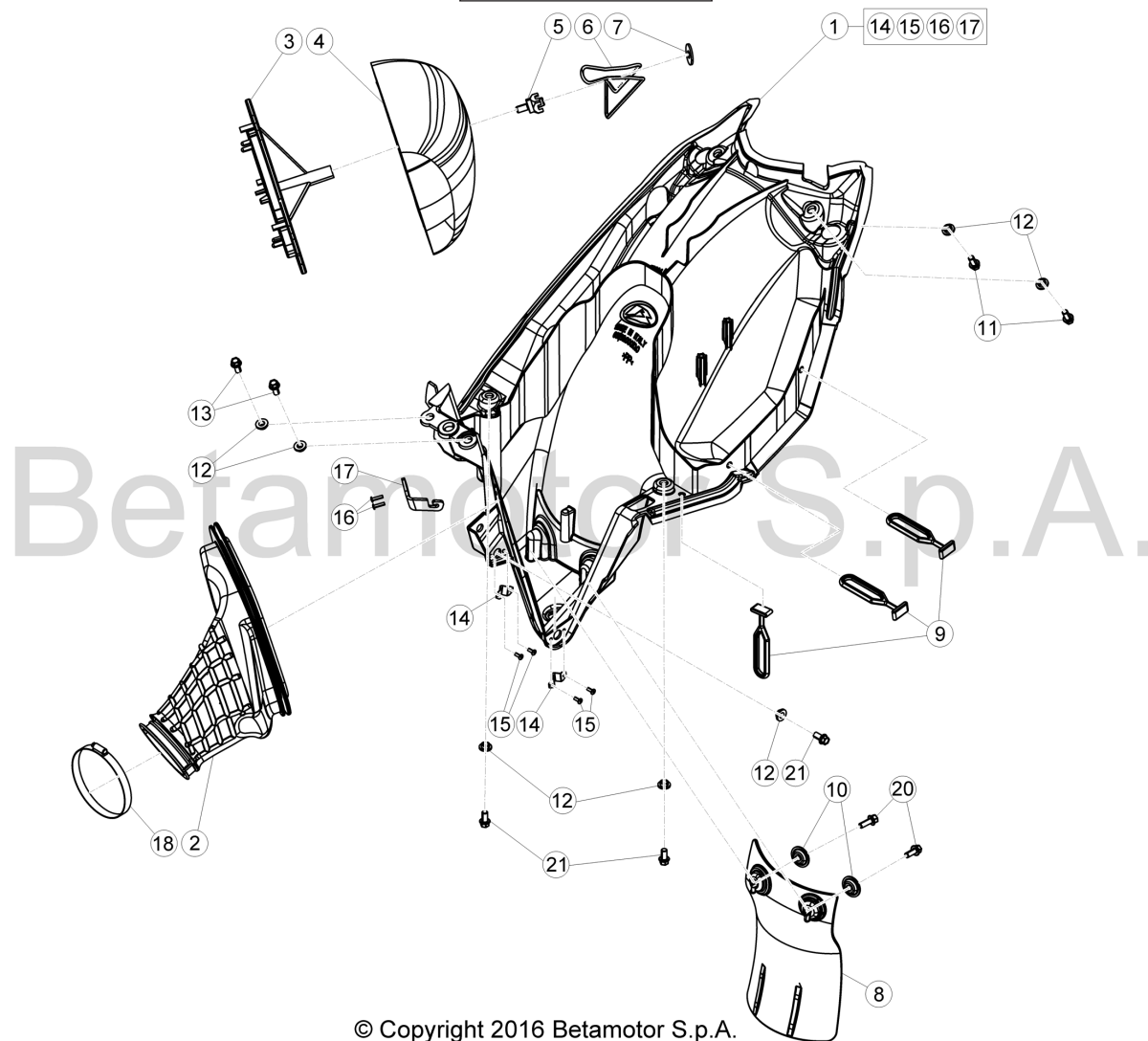

© Copyright 2016 Betamotor S.p.A.

Pos	Numero	Q.tà	Nota	Descrizione	Description	Désignation	Beschreibung	Descripció
Loc	Number	Q.ty	Note					
Pos	Numéro	Q.té	Note					
Ps	Número	M.ge	Nota					
Pos	Nummer	C.ad	Anm.					
1	026.38.006.80.59	1		Scatola filtro completa	Air cleaner box	Boî tier filtre à air	Lufiltergehäuse	Caja filtro de aire
2	026.38.001.00.00	1		Manicotto scatola filtro	Filter box sleeve	Manchon boî te du filtre	Filtergehäuseummuffe	Manguito caja filtro
3	026.38.002.00.00	1		Gabbia filtro aria	Filter cage	Grille filtre aire	Filter kafig	Jaula filtro aire
4	031.38.001.00.00	1		Filtro aria	Air filter	Filtre à air	Lufifilter	Filtro de aire
5	25.57197.000	1		Perno richiamo ferma-filtro	Filter pin	Pivot filtre	Filterhalter	Pin Eje filtro
6	020.38.021.00.00	1		Molla fermafiltro	Filter spring	Ressort filtre	Filter Feder	Muelle filtro
7	27.74800.000	1		Rondella autobloccante 9	Washer 9	Rondelle 9	Scheibe 9	Arandela 9
8	026.38.007.10.59	1		Protezione ammortizzatore	Rear damper protection	Protection amortisseur	Stosdämpferschutz	Protecció amortiguador
9	16.34907.000	3		Gommino	Rubber buffer	Caoutchouc	Gummi	Goma
10	27.74786.000	2		Rondella bombata	Kasher	Rondelle	Scheibe	Arandela
11	31.79960.000	2		Vite autofilettante M6x15	Self tapping screw M6x15	Vis taraud M6x15	Schraube, Blech M6x15	Tornillo autorrosc. M6x15
12	13.54820.000	7		Distanziale 6,5x9,0x13,5	Spacer 6,5x9,0x13,5	Entretoise 6,5x9,0x13,5	Distanzstück 6,5x9,0x13,5	Distanciador 6,5x9,0x13,5
13	11.47015.000	2		Bullone M6x12	Bolt M6x12	Boulon M6x12	Bolzen M6x12	Tornillo M6x12
14	026.38.004.00.00	2		Ricettacolo	Receptacle	Rè ceptacle	Behälter	Receptaculo
15	C18.19.009.00.00	4		Rivetto a strappo 2,4x8	Rivet 2,4x8	Rivet 2,4x8	Niet 2,4x8	Remache 2,4x8
16	27.33803.000	2		Rivetto a strappo 3x12	Rivet 3x12	Rivet 3x12	Niet 3x12	Remache 3x12
17	020.38.002.00.00	1		Braccetto	Arm	Bras	Kleine Stütze	Braso
18	15.14272.000	1		Fascetta raccordo aspirazione	Connecting hose clamp	Collier tuyau d' aspiration	Schelle Schlauchstutzen	Abrazadera tubuladura de empalme
20	31.30815.000	2		Vite autofilettante 6x20	Self tapping screw 6x20	Vis taraud 6x20	Schraube, Blech 6x20	Tornillo autorrosc. 6x20
21	11.48025.000	3		Bullone 6x16 ch 8 rs	Bolt 6x16 ch 8 rs	Boulon 6x16 ch 8 rs	Bolzen 6x16 ch 8 rs	Tornillo 6x16 ch 8 rs

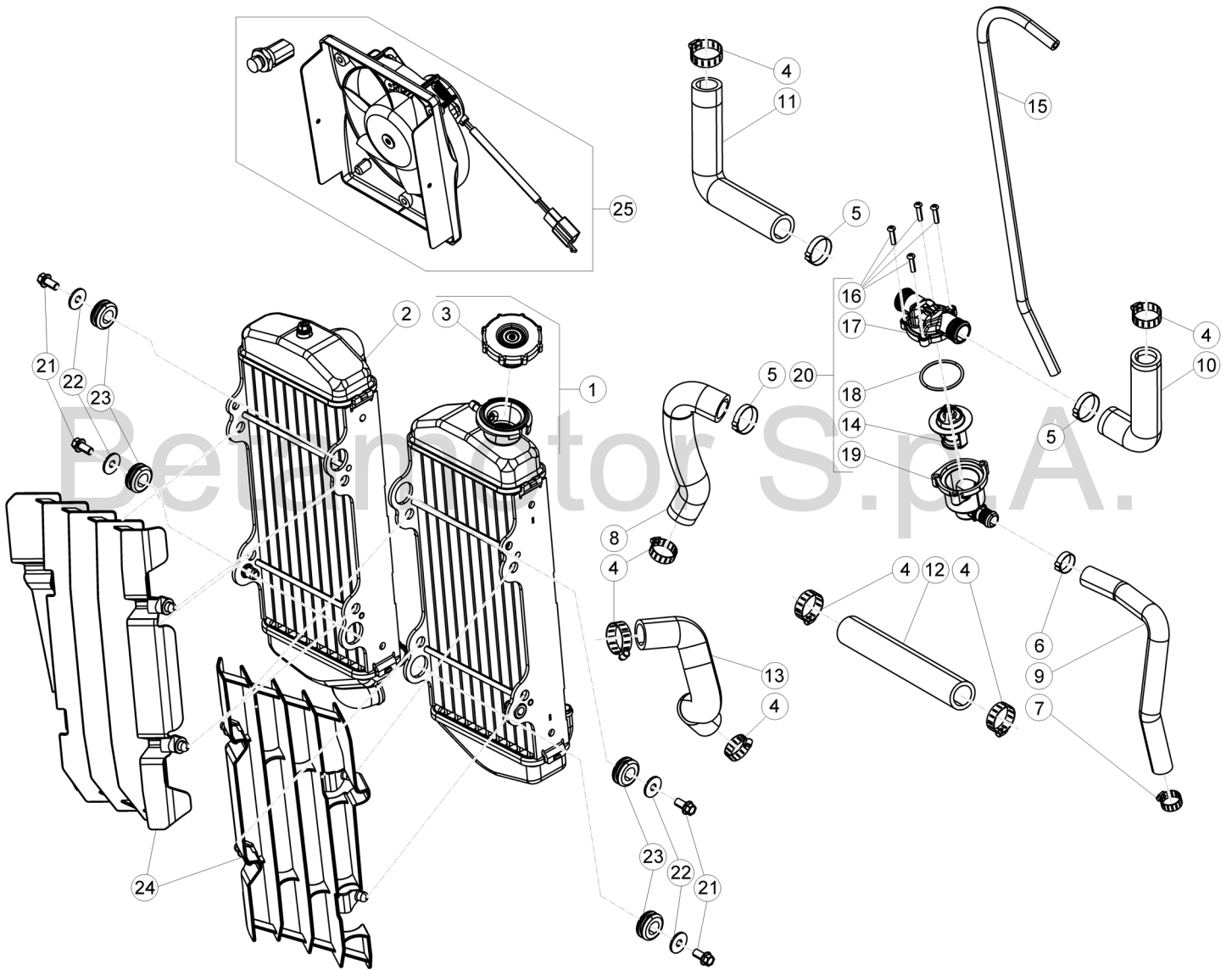

© Copyright 2016 Betamotor S.p.A.

# Tav.39

Pos Loc Pos Ps Pos	Numero Number Numéro Número Nummer	Q.tà Q.ty Q.té M.ge C.ad	Nota Note Note Nota Anm.	Descrizione	Description	Désignation	Beschreibung	Descrìcion
1	026.39.010.00.00	1		Radiatore sx	L.H. radiator	Radiateur G.	L., Kühler	Radiador iz.
2	026.39.000.00.00	1		Radiatore dx	R.H. radiator	Radiateur D.	R., Kühler	Radiador der.
3	020.39.111.00.00	1		Tappo radiatore	Radiator plug	Bouchon radiateur	Kühlerdeckel	Tapa de radiador
4	15.15240.000	7		Fascetta 19/28	Clamp 19/28	Collier 19/28	Schelle 19/28	Abrazadera 19/28
5	020.39.008.00.00	3		Fascetta 24	Clamp 24	Collier 24	Schelle 24	Abrazadera 24
6	020.39.009.00.00	1		Fascetta 17	Clamp 17	Collier 17	Schelle 17	Abrazadera 17
7	15.15220.000	1		Fascetta 12/22	Clamp 12/22	Collier 12/22	Schelle 12/22	Abrazadera 12/22
8	026.39.001.00.00	1		Tubo termostato-testa	Thermostat-head pipe	Canalisation thermostat-culasse	Leitung Thermostat-Zylinderkopf	Tubo termostato-culata
9	026.39.002.00.00	1		Tubo inf. Termostato	Thermostat lower hose	Tube inf. interrupteur thermique	Thermostatschlauch, unten	Tubo inf. Termostato
10	026.39.022.00.00	1		Tubo termostato sx	L.H. Thermostat hose	Tuyau interr. thermique G.	Leitung Thermostat li.	Tubo termostato izq.
11	026.39.021.00.00	1		Tubo termostato dx	R.H. Thermostat hose	Tuyau interr. thermique D.	Leitung Thermostat re.	Tubo termostato der.
12	026.39.005.00.00	1		Tubo inferiore radiatori	Lower radiators tube	Tube radiateurs inf.	Wasserschlauch Kühler unten	Tubo radiadores inferior
13	026.39.006.00.00	1		Tubo pompa acqua	Water pump pipe	Tube pompe eau	Leitung wasserpumpe	Tubo bomba agua
14	026.39.013.00.00	1		Termostato	Bimetal, thermostatic	Thé rmostat	Thermostat	Termostato
15	026.39.007.00.00	1		Tubo sfciato radiatore	Radiator breather pipe	Tuyau vidange radiateur	Kühlerentlüftungsrohr	Tubo ventilació n radiador
16	031.39.017.50.00	4		Vite	Screw	Vis	Schraube	Tornillo
17	031.39.016.00.00	1		Coperchio termostato	Thermostat cover	Couvercle du thermostat	Thermostatabdeckung	Tapa del termostato
18	10.66830.000	1		Anello OR 32.2	Ring OR 32.2	Circlips OR 32.2	Ring OR 32.2	Anillo OR 32.2
19	031.39.015.00.00	1		Contenitore termostato	Thermostat container	Logement interrupteur thermique	Rahmen Thermostatschlauch	Plástico termostato
20	026.39.020.80.00	1		Termostato completo	Thermostat, assy	Thermostat complet	Thermostat komplett	Termostato compl.
21	11.47015.000	4		Bullone M6x12	Bolt M6x12	Boulon M6x12	Bolzen M6x12	Tornillo M6x12
22	27.43250.000	4		Rondella 6x24	Washer 6x24	Rondelle 6x24	U.Scheibe 6x24	Arandela 6x24
23	16.34911.000	4		Gommino	Rubber buffer	Caoutchouc	Gummi	Goma
24	031.39.003.00.51	1		Coppia griglie radiatore	Radiator grills	Couples calandres	Kühlergrill	Rejas del radiador
25	026.46.001.82.00	1		Kit elettroventola (opzionale)	Electric fan kit (optional)	Jeu electro-ventilateur (Option)	Elektrolüftersatz (Optionsbaustein)	Kit electroventilador (opcional)

## GR. COMPONENTI ELETTRICI/CABLAGGI

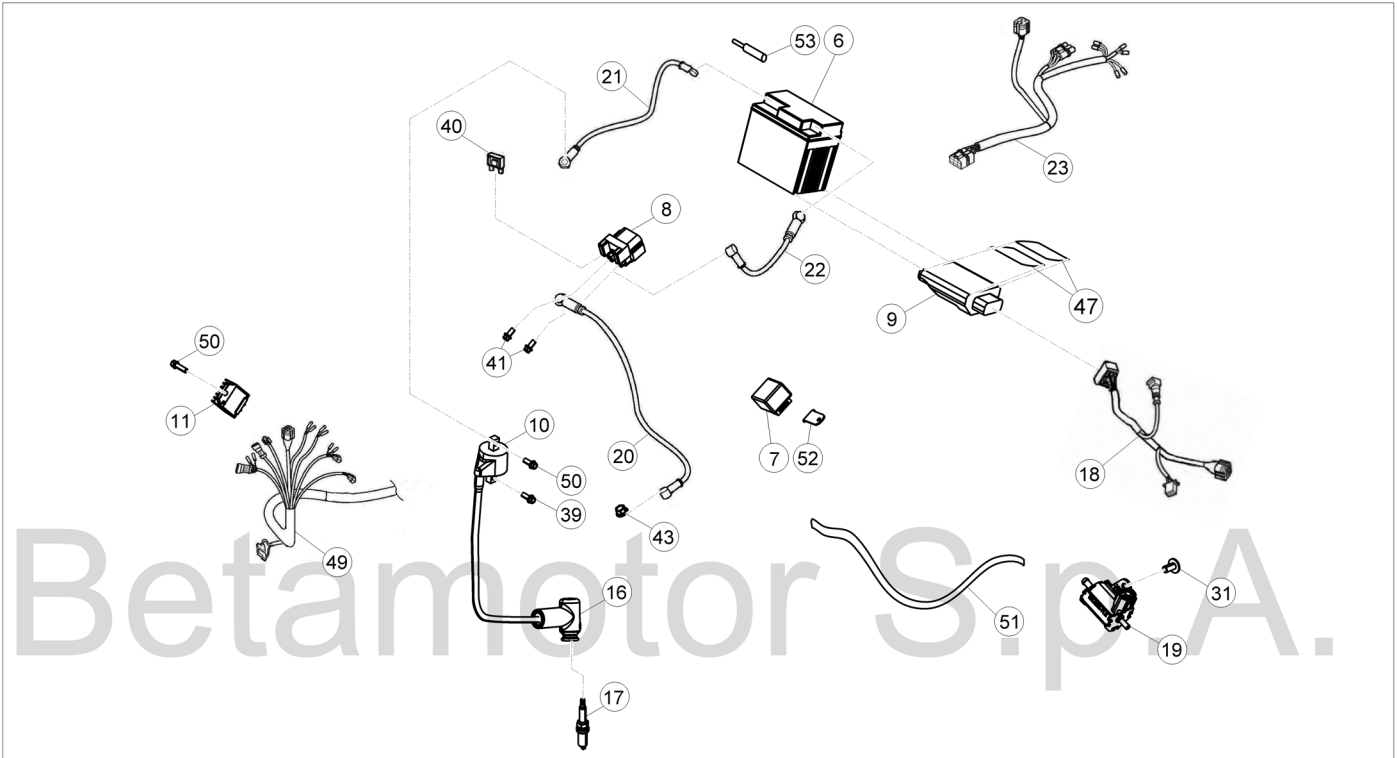

## GR. LUCI/INDICATORI

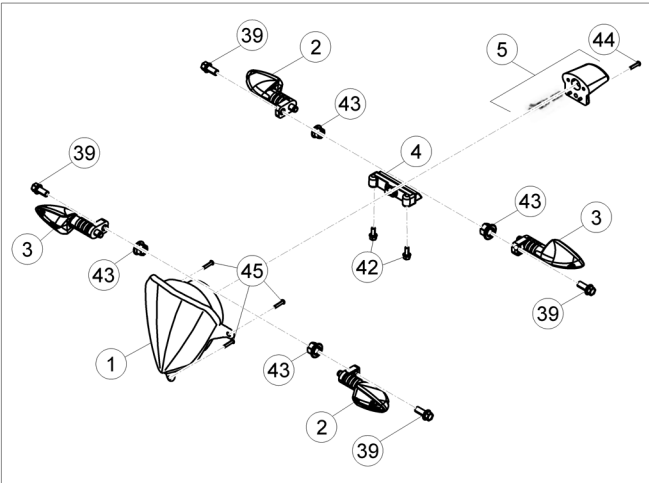

## GR. STRUMENTAZIONE

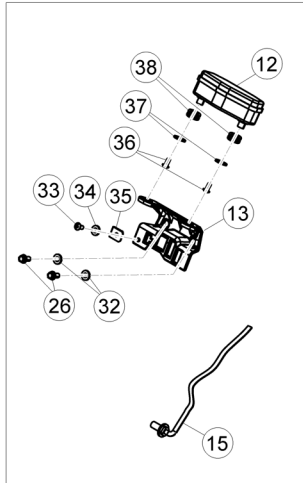

## GR. AVV. ACUSTICO

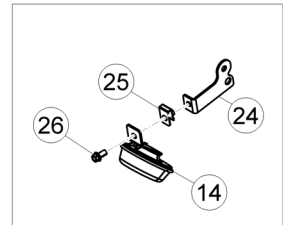

## GR. ACCESSORI

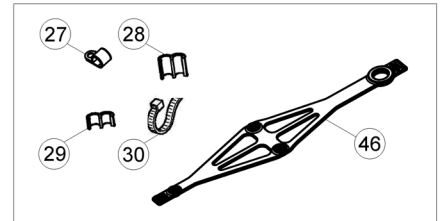

© Copyright 2016 Betamotor S.p.A.

# Tav.40

Pos Loc Pos Ps Pos	Numero Number Numéro Nummer	Q.tà Q.ty Q.té M.ge C.ad	Nota Note Nota Anm.	Descrizione	Description	Dé signation	Beschreibung	Descrìpò n
1	031.40.006.00.00	1		Gruppo ottico	Semi sealed beam unit	Groupe optique	Scheinwerfer	Grupo óptico
2	020.40.061.00.00	2		Indicatore dir. ant. sx.-post. Dx	Turn signal L.H.front-R.H.rear	Clignotant av.g.-ar.dr.	Blink. Vorderer links-Hinterer rechts	Indicador del. izq.-tras. der.
3	020.40.060.00.00	2		Indicatore dir. ant. dx.-post. Sx	Turn signal R.H.front-L.H.rear	Clignotant av.dr.-ar.g.	Blink.Vorderer rechts-Hinterer links	Indicador del. der.-tras. izq.
4	020.40.030.80.00	1		Fanalino posteriore a led	LED tail lamp	Feu AR. à diodes	LED-Rücklicht	Piloto a LED
5	020.40.020.00.00	1		Luce Targa	Plate illumination	Éclairage De Plaque	Kennzeichen-Beleuchtung	Iluminación Placa
6	11.15416.000	1		Batteria	Battery	Batterie	Batterie	Bateria
7	18.84948.000	1		Intermittenza	Unit turn signal lamps	Disp. comm. clignot.	Blinkgeber	Disp. intermitentes
8	27.28471.000	1		Relais	Relay	Relais	Relay	Relé
9	026.40.023.83.00	1	250cc	Centralina digitale	CDI unit	Bobine digital (C.D.I.)	Steuergerät	Centralita digital
9	026.40.022.83.00	1	300cc	Centralina digitale	CDI unit	Bobine digital (C.D.I.)	Steuergerät	Centralita digital
10	006.40.010.80.00	1		Bobina accensione	Ignition coil	Bobine allumage	Zuendspule	Bobina de encendido
11	27.28101.000	1		Regolatore	Regulator	Régulateur	Regler	Regulador
12	026.40.029.00.00	1		Strumento digitale	Digital instrument	Instrument numé rique	Digitalinstrument	Instrumento digital
13	031.40.011.00.00	1		Supporto strumento	Instrument holder	Support instruments	Instrumentenhalter	Soporte instrumentos
14	007.40.050.00.00	1		Avvisatore acustico	Warning horn	Avertisseur sonore	Hupe	Claxon
15	28.79013.000	1		Sensore REED	REED sensor	Sensor REED	Sensor	Sensor REED
16	27.13514.000	1		Raccordo candela	Plug fitting	Raccord bougie	Kerzenanschluß	Racor bujía
17	12.25123.000	1	250cc	Candela	Spark plug	Bougie	Zündkerze	Bujía
17	036.11.000.00.00	1	300cc	Candela	Spark plug	Bougie	Zündkerze	Bujía
18	026.40.024.00.00	1		Cablaggio elettrico principale	Main electric wiring	Câ blage é lectrique principale	Hauptelektroverkabelung	Cableado elé ctrico principal
19	026.40.017.00.00	1		Pompa olio	Oil pump	Pompe huile	Ölpumpe	Bomba aceite
20	026.40.006.00.00	1		Cavetto relè avviamento	Starter relay cable	Câ ble relais de demarrage	Anlassrelaiskabel	Cable relé de arranque
21	020.40.002.00.00	1		Cavetto di massa	Ground cable	Cable masse	Masse kabel	Cable masa
22	020.40.003.00.00	1		Cavo batteria-relè	Battery-Relay cable	Cable batterie-realis	Kabel Batterie-Relais	Cable Batería-relé
23	031.40.042.00.00	1		Impianto posteriore	Rear harness	Circuit post.	Anlage hinten	Instalación tras.
24	28.97255.000	1		Staffa supporto avvisatore acustico	Horn support bracket	Bride support avertisseur	Hupebefestigung	Brida soporte claxon
25	25.60311.000	1		Piastrina elastica M6	Spring plate M6	Plaque é lastique M6	Plättchen M6	Pletina elástica M6
26	11.47015.000	3		Bullone M6x12	Bolt M6x12	Boulon M6x12	Bolzen M6x12	Tornillo M6x12
27	15.14654.000	1		Fascetta	Clamp	Collier	Schelle	Abrazadera
28	25.24442.000	3		Passacavo 6/8	Fair lead 6/8	Passe-fils 6/8	Kabelführung 6/8	Pasa-cable 6/8
29	25.24443.000	3		Passacavo 6/6	Fair lead 6/6	Passe-fils 6/6	Kabelführung 6/6	Pasa-cable 6/6
30	15.14264.000	4		Fascetta	Clamp	Collier	Schelle	Abrazadera
31	31.95510.000	1		Vite TBCE M6x12	Screw TBCE M6x12	Vis TBCE M6x12	Schraube TBCE M6x12	Tornillo TBCE M6x12
32	13.54820.000	2		Distanziale 6,5x9,0x13,5	Spacer 6,5x9,0x13,5	Entretoise 6,5x9,0x13,5	Distanzstück 6,5x9,0x13,5	Distanciador 6,5x9,0x13,5
33	31.23530.000	1		Vite M4,2x16 TMTIC autofilettante	Self tapping screw M4,2x13 TMTIC	Vis taraud M4,2x13 TMTIC	Schraube Blech M4,2x13 TMTIC	Tornillo M4,2x13 TMTIC autorroscante
34	27.34800.000	1		Rondella grower 4x16	Grower washer 4x16	Rondelle Grower 4x16	Federring Grower 4x16	Arandela elástica Grower 4x16
35	25.58090.000	1		Piastrina elastica	Spring plate	Plaque é lastique	Plättchen	Pletina elástica
36	31.26190.000	2		Vite M4x12 TCIC	Screw M4x12 TCIC	Vis M4x12 TCIC	Schraube M4x12 TCIC	Tornillo M4x12 TCIC
37	020.40.812.00.00	2		Distanziale 5x15	Spacer 5x15	Entretoise 5x15	Distanzstück 5x15	Distanciador 5x15
38	031.40.013.00.00	2		Gommino	Rubber buffer	Caoutchouc	Gummi	Goma
39	11.48025.000	5		Bullone 6x16 ch 8 rs	Bolt 6x16 ch 8 rs	Boulon 6x16 ch 8 rs	Bolzen 6x16 ch 8 rs	Tornillo 6x16 ch 8 rs
40	020.40.006.00.00	2		Fusibile 10A	Fuse 10A	Fusible 10A	Sicherung 10A	Fusible 10A
41	31.30190.000	2		Vite a brugola 6x8	Allen screw 6x8	Vis à 6 pans 6x8	Sechskantschraube 6x8	Tornillo a llave allen 6x8
42	11.46251.000	2		Bullone flangiato M5x12	Head Flanged bolt M5x12	Boulon Bridé M5x12	Bundbolzen M5x12	Bulón con Brida M5x12
43	13.12550.000	5		Dado flangiato M6	Flanged nut M6	Ecrou bordé M6	Flanschmutter M6	Tuerca embreadada M6
44	31.23565.000	1		Vite 4,5x15 TCCCR	Screw 4,5x15 TCCCR	Vis 4,5x15 TCCCR	Schraube 4,5x15 TCCCR	Tornillo 4,5x15 TCCCR
45	31.26190.000	3		Vite M4x12 TCIC	Screw M4x12 TCIC	Vis M4x12 TCIC	Schraube M4x12 TCIC	Tornillo M4x12 TCIC
46	026.40.009.00.00	1		Elastico fermabatteria	Battery elastic strap	Sangle batterie	Gummiband Batteriebefestigung	Elastico sujeta batería
47	29.10317.000	2		Tampone	Buffer	Silentbloc	Puffer	Silent-block
49	026.40.035.00.00	1		Cablaggio anteriore	Front wiring	Câ blage avant	Vorderer Kabelbaum	Cableado delantero
50	11.49070.000	2		Bullone 6x20 ch rs	Bolt 6x20 ch rs	Boulon 6x20 ch rs	Bolzen 6x20 ch rs	Tornillo 6x20 ch rs
51	026.43.027.00.00	1		Tubo olio	Oil tube	Tuyau huile	Schlauch	Tubo aceite
52	031.40.002.22.00	1		Piastrina per intermittenza	Plate (flash device)	Plaque intermittence	Platte Blinkgeber	Placa intermitencia
53	031.40.051.00.00	1		Condensatore	Condenser	Condensateur	Kondensator	Condensador

# Tav.41

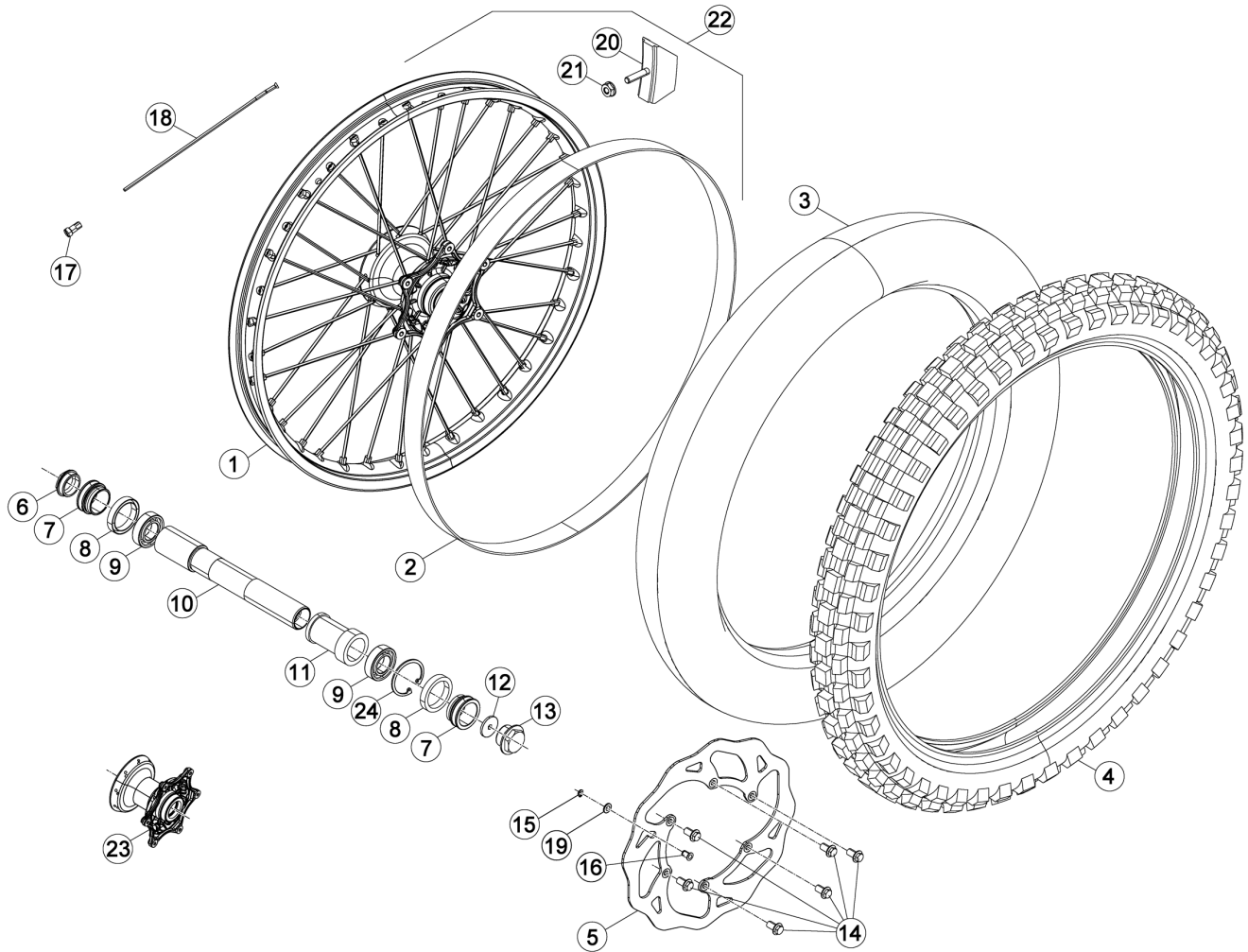

Pos Loc Pos Ps Pos	Numero Number Numéro Número Nummer	Q.tà Q.ty Q.té M.ge C.ad	Nota Note Note Nota Anm.	Descrizione	Description	Désignation	Beschreibung	Descripció
1	031.41.046.00.33	1		Cerchio anteriore	Front rim	Jante avant	Vorderfelge	Llanta delantera
2	15.38200.000	1		Flap 21x25	Bead 21x25	Flap21x25	Felgenband 21x25	Flap cinta tapa radios 21.25
3	036.41.008.00.00	1		Camera 2.50/21-2.75-21	Tube 2,50x21-2,75x21	Tube 2,50x21-2,75x21	Schlauch 2,50x21-2,75x21	Camara 2,50x21-2,75x21
4	12.81575.000	1		Copertura	Tyre	Pneu	Reifen	Neumático
5	031.41.030.00.00	1		Disco freno	Brake plate	Disque frein	Bremscheibe	Disco freno
6	020.41.007.00.00	1		Tappo perno ruota anteriore	Front wheel pin plug	Bouchon pivot roue avant	Stopfen Pin Vorrad	Tapon eje rueda anterior
7	031.41.004.00.00	2		Distanziale ant.	Front spacer	Entretoise AV.	Distanzstück vorderer	Distanciadador del.
8	10.66000.000	2		Paraolio 35x47x7	Oil seal 35x47x7	Pare-huile 35x47x7	Dichtring 35x47x7	Sello de lub. 35x47x7
9	020.41.003.00.00	2		Cuscinetto 30x47x9	Bearing 30x47x9	Roulement 30x47x9	Lager 30x47x9	Cojinete 30x47x9
10	020.41.005.00.00	1		Perno ruota anteriore	Front wheel spindle	Pivot roue AV.	Vorderradzapfen	Perno rueda delantera
11	031.41.015.00.00	1		Distanziale interno	Inner spacer	Entretoise interne	Inneres Distanzstück	Distanciadador interior
12	020.41.110.00.00	1		Tappo interno perno ruota anteriore	Front wheel pin inner plug	Bouchon int. pivot roue avant	Innerstopfen Pin Vorrad	Tapon int. eje rueda anterior
13	020.41.006.00.00	1		Tappo filettato	Threaded plug	Bouchon fileté	Gewindepropf	Tapòn filete
14	031.41.016.00.00	6		Vite TEF M6x14	Screw TEF M6x14	Vis TEF M6x14	Schraube TEF M6x14	Tornillo TEF M6x14
15	28.22660.000	1		Seeger 9E	Circlip 9E	Circlip 9E	Seeger 9E	Seeger 9E
16	021.41.005.00.00	1		Magnete	Magneto	Magneto	Magnet	Magneto
17	020.41.013.00.00	36		Nipplo	Nipple	Ecrou	Nippel	Tuerca
18	031.41.049.00.52	36		Raggio	Spoke	Rayon	Speiche	Radio
19	27.58080.000	1		Rondella spess. 9x13x0,4	Washer 9x13x0,4	Rondelle epaisseur 9x13x0,4	Scheibe 9x13x0,4	Arandela 9x13x0,4
20	036.41.010.00.00	1		Fermacopertone	Tyre retainer	Arrêt pneu	Felgenhalterung	Sujeta cobertura
21	13.17120.000	1		Dado M8 flangiato	Nut M8	Ecrou M8	Mutter M8	Tuerca M8
22	026.41.001.00.00	1		Ruota anteriore p/montata	Fr. wheel assy.	Roue AV. p/monte'	Vormontiertes Vorderrad	Rueda delantera montada
23	031.41.014.80.00	1		Mozzo anteriore c/cuscinetti	Front hub with ballbearing	Moyeu avant avec roulements	Nabe vo.	Buje ant.c/cojinetes
24	001.26.001.00.00	1		Seeger 47x1,75	Circlip 47x1,75	Circlip 47x1,75	Seeger 47x1,75	Seeger 47x1,75



# Tav.42

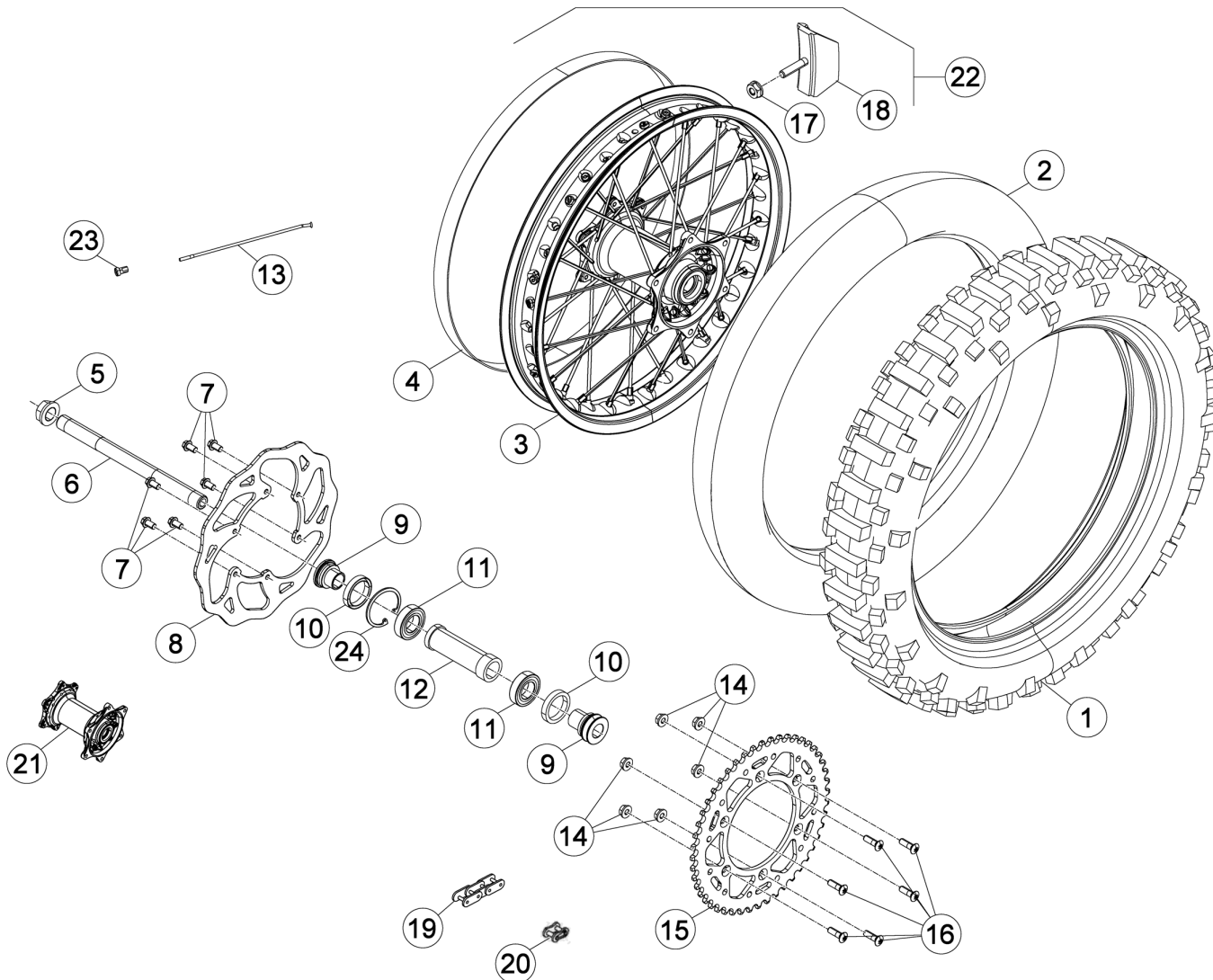

Pos Loc Pos Ps Pos	Numero Number Numéro Número Nummer	Q.tà Q.ty Q.té M.ge C.ad	Nota Note Note Nota Anm.	Descrizione	Description	Désignation	Beschreibung	Descrìption
1	031.42.012.00.00	1		Copertura	Tyre	Pneu	Reifen	Neumático
2	036.42.006.00.00	1		Camera	Tube	Tube	Schlauch	Camara
3	031.42.034.00.33	1		Cerchio ruota posteriore	Rear wheel rim	Janta roue AR.	Hinterradfelge	Llanta rueda trasera
4	15.36000.000	1		Flap 17/18x25	Bead 17/18x25	Flap 17/18x25	Felgenband 17/18x25	Flap cinta tapa radios 17/18x25
5	13.27120.000	1		Dado speciale	Special nut	Ecrou spéciale	Spezialmutter	Tuerca especial
6	25.55812.000	1		Perno ruota posteriore	Rear wheel pin	Pivot roue arrière re	Hinterradbolzen	Perno rueda trasera
7	031.41.016.00.00	6		Vite TEF M6x14	Screw TEF M6x14	Vis TEF M6x14	Schraube TEF M6x14	Tornillo TEF M6x14
8	031.42.030.00.00	1		Disco freno posteriore	Rear brake disk	Disque frein arrière re	Hinterbremscheibe	Disco freno trasero
9	031.42.002.00.00	2		Distanziale mozzo post. Dx	RH rear hub spacer	Entretoise moyeu arrière D.	Distanz li	Distanciadior buje tras. Der.
10	10.66000.000	2		Paraolio 35x47x7	Oil seal 35x47x7	Pare-huile 35x47x7	Dichtring 35x47x7	Sello de lub. 35x47x7
11	020.42.004.00.00	2		Cuscinetto 25x47x12	Bearing 25x47x12	Roulement 25x47x12	Lager 25x47x12	Cojinete 25x47x12
12	031.42.005.00.00	1		Distanziale interno	Inner spacer	Entretoise interne	Inneres Distanzstück	Distanciadior interior
13	031.42.037.00.52	36		Raggio ruota posteriore	Rear wheel spokes	Rayons roue AR.	Hinterradspokein	Radios rueda trasera
14	13.17123.000	6		Dado TECF M8	Nut TECF M8	Ecrou TECF M8	Mutter TECF M8	Tuerca TECF M8
15	026.42.005.00.00	1		Corona Z49	Ring gear Z49	Couronne Z49	Zahnkranz Z49	Corona Z49
16	31.96827.000	6		Vite speciale M8X26	Special screw M8X26	Vis spéciale M8X26	Spezialschraube M8X26	Tornillo especial M8X26
17	13.17120.000	1		Dado M8 flangiato	Nut M8	Ecrou M8	Mutter M8	Tuerca M8
18	036.42.009.00.00	1		Fermacopertone	Tire fastener	Caoutchouc serrure chambre	Reifen Halter	Agarre cubierta ant.
19	031.42.003.00.00	1		Catena P114	Chain P114	Chaî ne P114	Kette P114	Cadena P114
20	031.42.008.00.00	1		Maglia congiunzione 5/8x1/4	Connecting link 5/8x1/4	Maillon jonction 5/8x1/4	Kettenschloss 5/8x1/4	Eganche cadena 5/8x1/4
21	031.42.014.80.00	1		Mozzo posteriore c/cuscinetti	Rear hub with ballbearing	Moyeu arrière avec roulements	Hinterrad Nabe	Buje del. c/cojinetes
22	026.42.008.00.00	1		Ruota posteriore p/montata	Front wheel assy.	Roue arrière p/monte'	Vormontiertes hinterrad	Rueda trasera montada
23	020.42.013.00.00	36		Nipplo	Nipple	Ecrou	Nippel	Tuerca
24	C01.26.001.00.00	1		Seeger 47x1,75	Circlip 47x1,75	Circlip 47x1,75	Seeger 47x1,75	Seeger 47x1,75



# Tav.43A

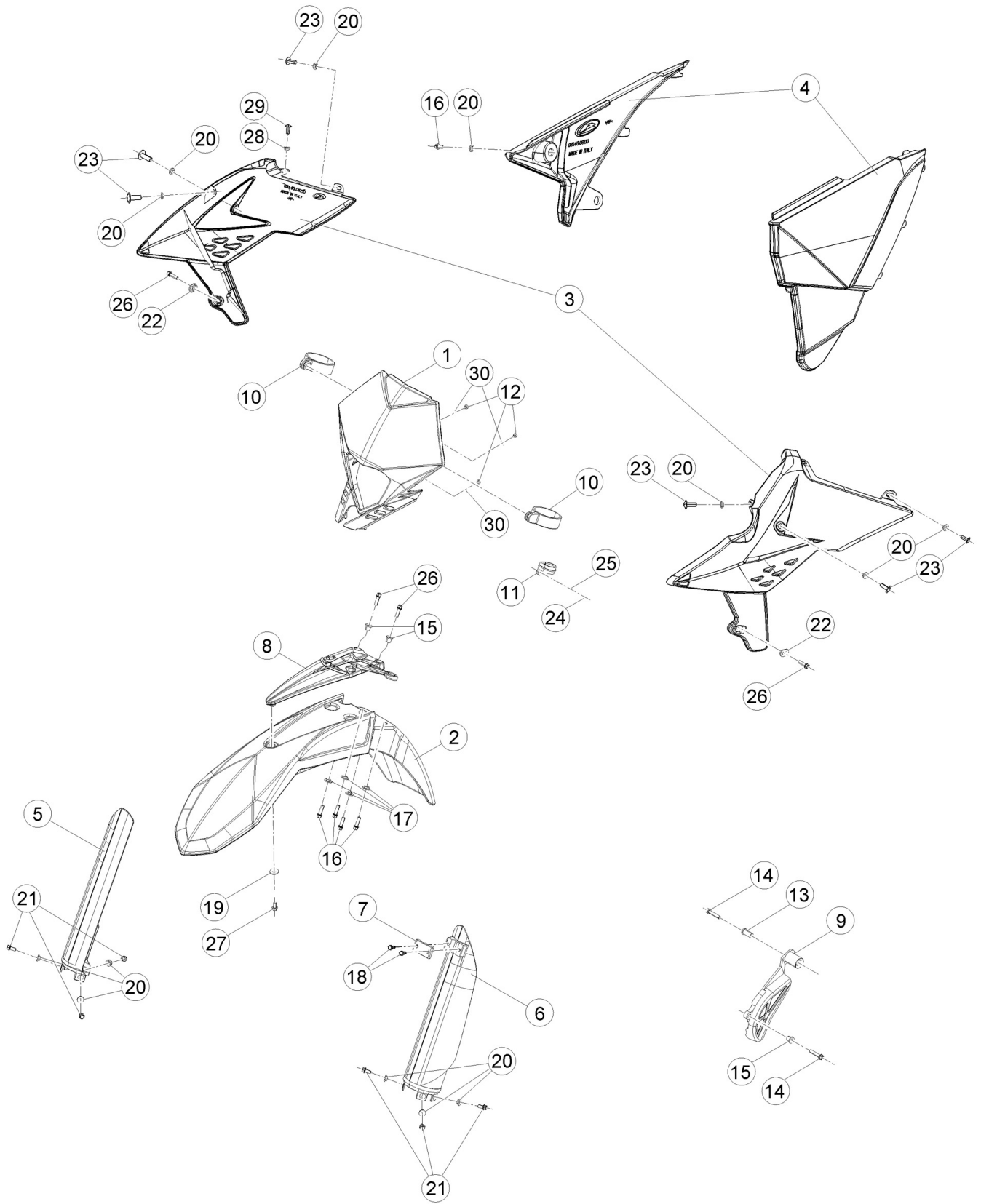

# Tav.43A

Pos Loc Pos Ps Pos	Numero Number Numéro Número Nummer	Q.tà Q.ty Q.té M.ge C.ad	Nota Note Note Nota Anm.	Descrizione	Description	Dé signation	Beschreibung	Descrìpziòn
1	020.43.150.10.97	1		Mascherina	Mask	Masque	Maske	Mà scara
2	031.43.034.10.97	1		Parafango	Mudguard	Garde-boue	Kotflü gel	Guardabarros
3	031.43.012.00.97	1		Fianchetti serbatoio	Tank panels	Panneaux laterales	Benzintankseiten	Flancos
4	026.43.021.00.97	1		Coppia fianchetti scatola filtro	Airbox panels, pair	Couple cote lat. boi tier filtre à air	Lufffiltergehä useseiten	Flancos derechos caja filtro aire
5	016.34.010.10.59	1		Protezione tubo forcella dx	RH fork tube protection	Protection tube fourche droit	Abdeckung Gabelschlauch re.	Protección tubo horquilla derecho
6	016.34.011.10.59	1		Protezione tubo forcella sx	LH fork tube protection	Protection tube fourche gauche	Abdeckung Gabelschlauch li.	Protección tubo horquilla izquierdo
7	25.91330.159	1		Ponticello tubo freno	Brake pipe sprocket	Etrier tube frein	Bü gel Bremsschlauch	Abrazadera tubo freno
8	020.43.141.10.59	1		Supporto parafango	Fender stay	Appui aile	Kotflü gelstuetze	Soporte de guardabarros
9	020.43.062.10.59	1		Coperchio pignone	Sprocket cover	Couvercle pignon	Deckel Ritzel	Tapa piñ ò n
10	14.40081.000	2		Elastico fissaggio mascherina	Headlight holder elastic rubber	Elastique de fixation cache phare	Befestigungsband Lichtschildchen	Elastico
11	25.24464.000	1		Passacavo	Grommet	Passe-câ ble	Kabeldurchgang	Pasacables
12	31.26190.000	3		Vite M4x12 TCIC	Screw M4x12 TCIC	Vis M4x12 TCIC	Schraube M4x12 TCIC	Tornillo M4x12 TCIC
13	13.49189.000	1		Distanziale	Spacer	Entretoise	Distanzstü ck	Distanciadò r
14	11.50300.000	2		Bullone 6x30 ch rs	Bolt 6x30 ch rs	Boulon 6x30 ch rs	Bolzen 6x30 ch rs	Tornillo 6x30 ch rs
15	13.49190.000	3		Distanziale 10mm	Spacer 10mm	Entretoise 10mm	Distanzstü ck 10mm	Distanciadò r 10mm
16	11.48025.000	5		Bullone 6x16 ch 8 rs	Bolt 6x16 ch 8 rs	Boulon 6x16 ch 8 rs	Bolzen 6x16 ch 8 rs	Tornillo 6x16 ch 8 rs
17	13.54841.000	4		Distanziale	Spacer	Entretoise	Distanzstü ck	Distanciadò r
18	31.79960.000	2		Vite autofilettante M6x15	Self tapping screw M6x15	Vis taraud M6x15	Schraube, Blech M6x15	Tornillo autorrosc. M6x15
19	27.74786.000	1		Rondella	Washer	Rondelle	U.Scheibe	Arandela
20	13.54820.000	13		Distanziale 6,5x9,0x13,5	Spacer 6,5x9,0x13,5	Entretoise 6,5x9,0x13,5	Distanzstü ck 6,5x9,0x13,5	Distanciadò r 6,5x9,0x13,5
21	11.47015.000	6		Bullone M6x12	Bolt M6x12	Boulon M6x12	Bolzen M6x12	Tornillo M6x12
22	020.43.012.00.00	2		Distanziale	Spacer	Entretoise	Distanzstü ck	Distanciadò r
23	31.95510.000	6		Vite TBCE M6x12	Screw TBCE M6x12	Vis TBCE M6x12	Schraube TBCE M6x12	Tornillo TBCE M6x12
24	31.23360.000	1		Vite autofilettante 4x10	Self tapping screw 4x10	Vis taraud 4x10	Schraube, Blech 4x10	Tornillo autorrosc. 4x10
25	27.34650.000	1		Rondella	Washer	Rondelle	U.Scheibe	Arandela
26	11.49070.000	4		Bullone 6x20 ch rs	Bolt 6x20 ch rs	Boulon 6x20 ch rs	Bolzen 6x20 ch rs	Tornillo 6x20 ch rs
27	11.46501.000	1		Bullone M6x10	Bolt M6x10	Boulon M6x10	Bolzen M6x10	Tornillo M6x10
28	13.62000.000	1		Distanziale	Spacer	Entretoise	Distanzstü ck	Distanciadò r
29	31.30035.000	1		Bullone M6x25 TBCEI	Bolt M6x25 TBCEI	Boulon M6x25 TBCEI	Bolzen M6x25 TBCEI	Tornillo M6x25 TBCEI
30	11.48025.000	3		Bullone 6x16 ch 8 rs	Bolt 6x16 ch 8 rs	Boulon 6x16 ch 8 rs	Bolzen 6x16 ch 8 rs	Tornillo 6x16 ch 8 rs

# Tav.43B

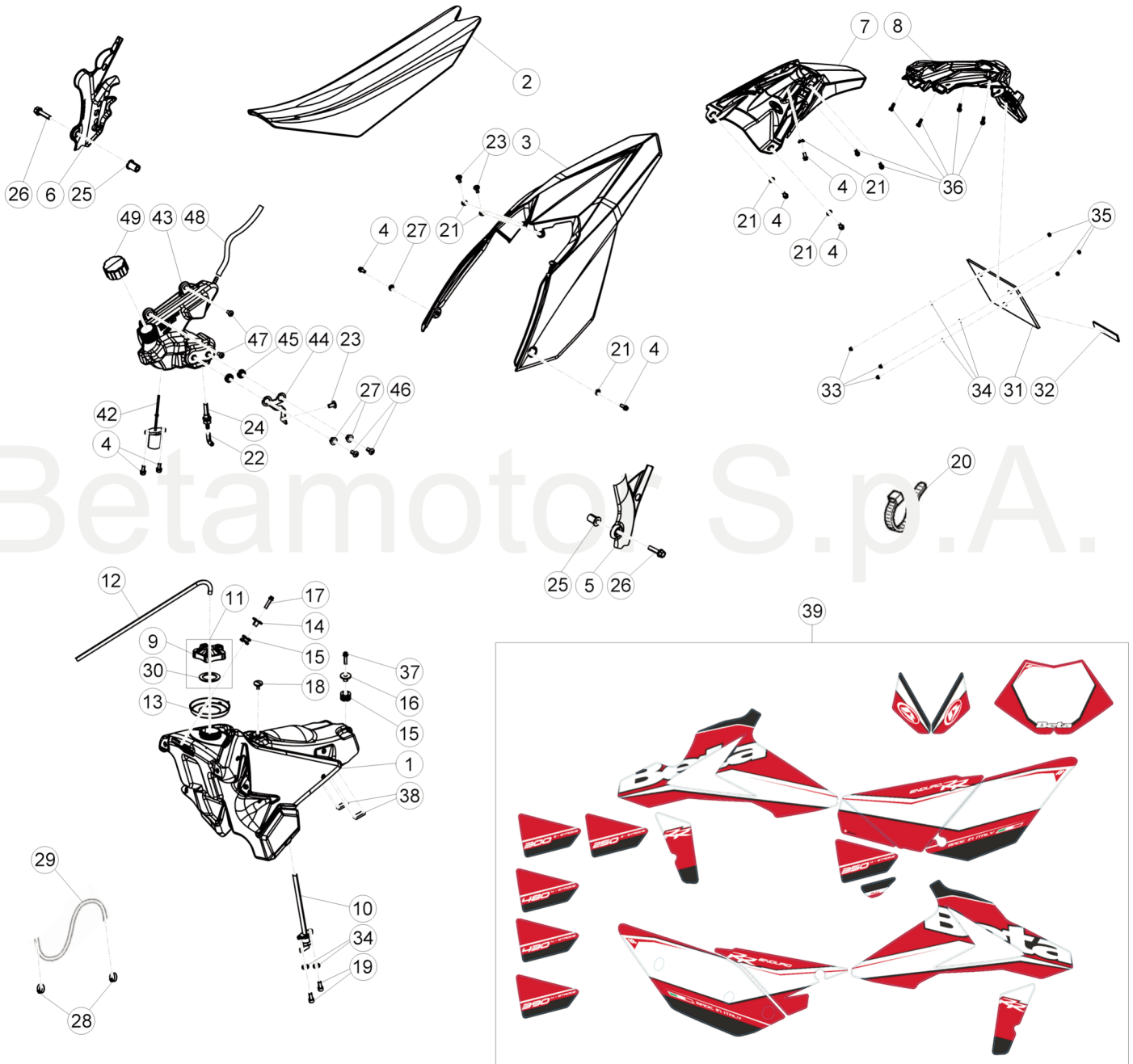

© Copyright 2016 Betamotor S.p.A.

# Tav.43B

Pos Loc Pos Ps Pos	Numero Number Numéro Nummer	Q.tà Q.ty Q.té M.ge C.ad	Nota Note Note Nota Anm.	Descrizione	Description	Dé signation	Beschreibung	Descrìpziò n
1	026.43.006.10.51	1		Serbatoio benzina	Fuel tank	Reservoir carb.	Kraftstofftank	Dep. carburante
2	031.43.059.00.00	1		Sella	Seat	Siege	Sattel	Sillin
3	031.43.030.10.97	1		Parafango posteriore	Rear mudguard	Garde-boue AR.	Hinterradkaufflügel	Guardabarros tras.
4	11.48025.000	7		Bullone 6x16 ch 8 rs	Bolt 6x16 ch 8 rs	Boulon 6x16 ch 8 rs	Bolzen 6x16 ch 8 rs	Tornillo 6x16 ch 8 rs
5	020.43.060.10.59	1		Protezione telaio Sx	L.H. frame guard	Protection chassis G.	Rahmenschutz Links	Protecciò n bastidor izquierda
6	020.43.061.10.59	1		Protezione telaio Dx	R.H. frame guard	Protection chassis D.	Rahmenschutz Rechts	Protecciò n bastidor derecha
7	036.43.006.10.59	1		Portatarga	Plate holder	Porte-plaque	Kennzeichenträger	Porta matr.
8	020.43.034.10.59	1		Portatarga omologazione	Homologati on plate holder	Porte-plaque homologation	Zulassungs Kennzeichenträger	Porta matr. Homologaciò n
9	026.43.031.80.00	1		Tappo serbatoio	Filler cap	Bouchon de ré servoir	Tankverschluss	Tapò n depò sito
10	020.43.007.00.00	1		Rubinetto benzina	Fuel cock.	Robinét melange	Kraftstoffhahn	Grifo mezcla
11	026.43.032.80.00	1		Tappo serbatoio benzina compl.	Tank cap assy.	Bouchon de ré servoir complet	Tankverschluss kpl.	Tapò n depò sito completo
12	021.43.006.00.00	1		Tubo sfiato	Bleeder pipe	Tuyau purge	Leitung Entlüftungsventil	Tubo purga de aire
13	026.43.029.00.00	1		Anello	O-Ring	Bague d' é tanché ité	O-Ring	Anillo
14	020.43.002.00.00	1		Distanziale mozzo post. Sx	LH rear hub spacer	Entretoise moyeu arriere G.	Distanz re	Distanciadò r buje tras. Izq.
15	28.91946.000	2		Silentbloc	Silentbloc	Silentbloc	Puffer	Silent-block
16	031.43.002.00.00	1		Distanziale	Spacer	Entretoise	Distanzstü ck	Distanciadò r
17	11.50010.000	1		Bullone M6x25	Bolt M6x25	Boulon M6x25	Bolzen M6x25	Tornillo M6x25
18	31.89010.000	1		Vite spec. bloccaggio sella	Seat locking screw	Vis blocage selle	Schraube	Tornillo bloqueo sillin
19	31.29810.000	2		Vite 5x12	Screw 5x12	Vis 5x12	Schraube 5x12	Tornillo 5x12
20	15.14264.000	1		Fascetta	Clamp	Collier	Schelle	Abrazadera
21	13.54820.000	6		Distanziale 6,5x9,0x13,5	Spacer 6,5x9,0x13,5	Entretoise 6,5x9,0x13,5	Distanzstü ck 6,5x9,0x13,5	Distanciadò r 6,5x9,0x13,5
22	036.43.022.00.00	1		Tubo olio	Oil tube	Tuyau huile	Schlauch	Tubo aceite
23	31.95510.000	3		Vite TBCE M6x12	Screw TBCE M6x12	Vis TBCE M6x12	Schraube TBCE M6x12	Tornillo TBCE M6x12
24	036.43.017.00.00	1		Raccordo	Joint.p.	Raccord	Stutzen	Racor
25	27.33740.000	2		Rivetto filettato M6	Threaded rivet M6	Rivet fileté M6	Niete mit gewinde M6	Remache roscado M6
26	11.49070.000	2		Bullone 6x20 ch rs	Bolt 6x20 ch rs	Boulon 6x20 ch rs	Bolzen 6x20 ch rs	Tornillo 6x20 ch rs
27	13.62000.000	3		Distanziale	Spacer	Entretoise	Distanzstü ck	Distanciadò r
28	007.08.008.00.00	2		Anello stringitubo CE12	Pipe clamping ring CE12	Anneau serre-tube CE12	Schlauchschele CE12	Anillo prensatubo CE12
29	026.43.005.00.00	1		Tubo serbatoio-carburatore	Tank-carburettor pipe	Tuyau ré servoir-carburateur	Tankleitung-Vergaser	Tubo radiador-carburador
30	031.43.116.00.00	1		Guarnizione tappo	Packing for cap	Joint bouchon	Deckeldichtung	Junta tapò n
31	018.43.010.10.59	1		Supporto targa	Licence plate bracket	Support plaque	Nummernschildträger	Sopò rte placa porta matrì cula
32	12.33086.000	1		Catadiottro posteriore	Rear reflector	Catadioptré AR.	Rückstrahler hinten	Catafaro tras.
33	13.11010.000	3		Dado autobloccante M5	Self locking nut M5	Ecrou de sé curité M5	Mutter, selbstsichernd M5	Tuerca de seguridad M5
34	27.36000.000	5		Rondella 5x11	Washer 5x11	Rondelle 5x11	U.Scheibe 5x11	Arandela 5x11
35	31.29860.000	3		Vite M5x16 TTLIC	Screw M5x16 TTLIC	Vis M5x16 TTLIC	Schraube M5x16 TTLIC	Tornillo M5x16 TTLIC
36	31.79960.000	6		Vite autofilettante M6x15	Self tapping screw M6x15	Vis taraud M6x15	Schraube, Blech M6x15	Tornillo autorosc. M6x15
37	11.50300.000	1		Bullone 6x30 ch rs	Bolt 6x30 ch rs	Boulon 6x30 ch rs	Bolzen 6x30 ch rs	Tornillo 6x30 ch rs
38	031.43.004.00.00	2		Tampone serbatoio	Tank buffer	Silentbloc ré servoir	Puffer tank	Silent-block deposito
39	031.43.112.82.00	1		Decalco serie completa	Transfer set	Sé rie Dé calcomanie	Serie Abziehbild	Seire Calcomani as
42	026.40.019.00.00	1		Indicatore di livello	Fuel level gauge	Jauge d' essence	Benzinstandgeber	Indicador de nivel
43	026.43.007.10.51	1		Serbatoio olio mix	Oil mix tank	Ré servoir d' huile mix	2-taktö lltank	Tanque aceite mezcla
44	036.43.021.22.00	1		Attacco pompa olio	Oil pump element	Element pompe huile	Ölpumpeneinsatz	Elemento de bomba aceite
45	28.91880.000	2		Silent block	Silentbloc	Silent block	Puffer	Silent block
46	31.30470.000	2		Vite 6x14 TBCE	Screw 6x14 TBCE	Vis 6x14 TBCE	Schraube 6x14 TBCE	Tornillo 6x14 TBCE
47	31.30035.000	2		Bullone M6x25 TBCEI	Bolt M6x25 TBCEI	Boulon M6x25 TBCEI	Bolzen M6x25 TBCEI	Tornillo M6x25 TBCEI
48	036.43.028.14.00	1		Tubo sfiato	Breather tube	Tuyau ré niffard	Entlü ftungsleitung	Tubo respiradero
49	036.43.010.00.00	1		Tappo serbatoio olio	Oil tank plug	Bouchon ré servoir d' huile	Ölbehälterverschluss	Tapò n depò sito aceite

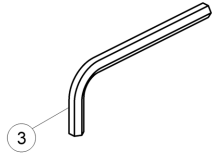

# Betamotor S.p.A.

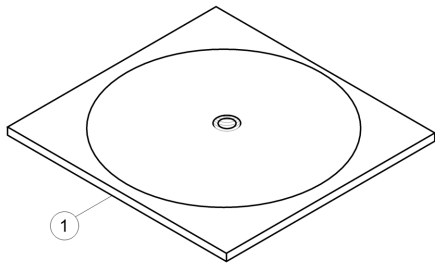

© Copyright 2016 Betamotor S.p.A.

Pos Loc Pos Ps Pos	Numero Number Numéro Número Nummer	Q.tà Q.ty Q.té M.ge C.ad	Nota Note Note Nota Anm.	Descrizione	Description	Dé signation	Beschreibung	Descrìpiò n
1	026.44.022.00.00	1		CD Manuale uso e manutenzione	Owner' s manual CD	CD Manuel d' utilisation et entretien	CD Bedienungs und Wartungshandbuch	CD Manual de Uso y Manutención
2	020.44.202.80.00	1		Borsa attrezzi	Tool roll	Trousse à outils	Werkzeugtasche	Bolsa herramientas
3	020.44.003.00.00	1		Chiave a brugola 6mm	Allen wrench 6mm	Clé Allen 6mm	Sechskantschlüssel 6mm	Llave de imbus 6mm
4	020.44.004.00.00	1		Bussola 8	Bush 8	Joint 8	Buchse 8	Buje 8



Handwriting practice area consisting of 25 horizontal dotted lines.



