

EVO 4T 2012
250/300cc

CATALOGO PARTI DI RICAMBIO
CATALOGUE OF SPARE PARTS
CATALOGUE PIECES DE RECHANGE
ERSATZTEILKATALOG
CATALOGO DE PIEZAS DE REPUESTO

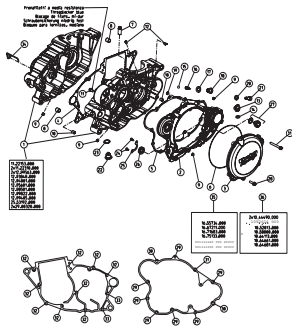

TAV.01 Basamento - Crankcase - Carter - Kurbelgehäuse - Carter



TAV.02 Albero motore-Pistone-Gruppo termico - Crankshaft-Piston-Thermal unit - Vilebrequin-Piston-Gr. Thermique - Kurbelwelle-Kolben-Thermischen Gruppe - Cigüeñal-Pistón-Grupo térmico

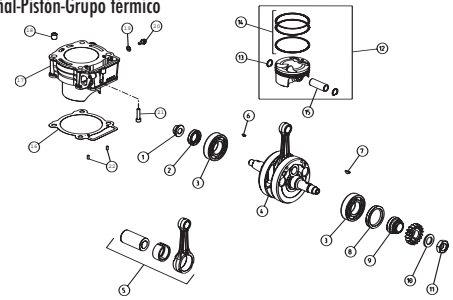

TAV.03 Frizione - Clutch - Embrayage - Kupplung - Embrague

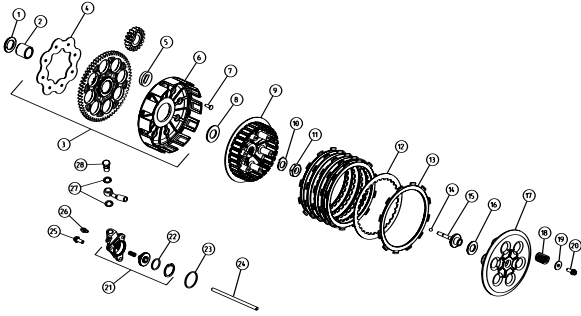

TAV.04 Ingranaggi cambio - Gear group - Engrenages changement de vitesses - Schaltgetriebe - Engranaje del cambio

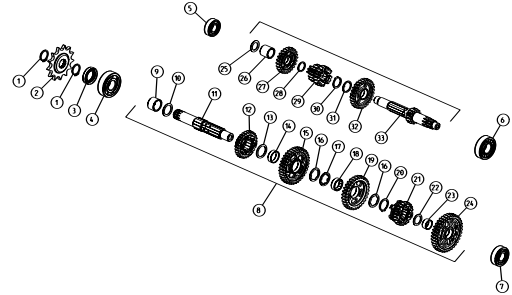

TAV.05 Comando cambio - Gear shift control - Commande changement de vitesse - Chaltung - Mando cambio

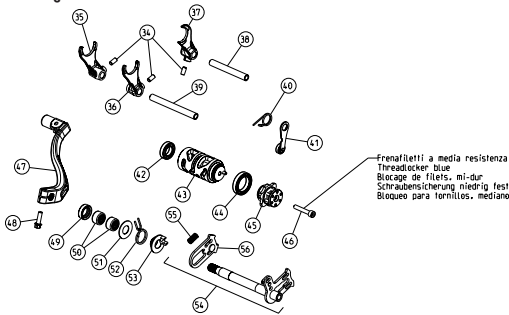

TAV.06 Avviamento a pedale - Kickstarter - Démarrage à pedal - Pedalstart - Arranque a pedal

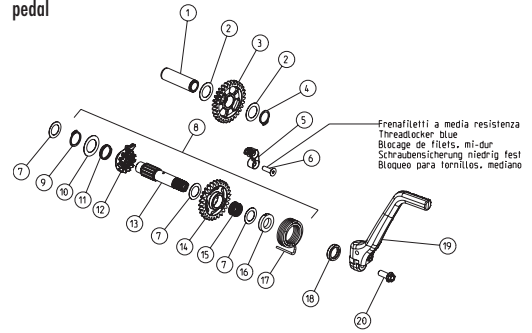

TAV.08 Pompa olio - Oil pump - Pompe d'huile - Ölpumpe - Bomba de aceite

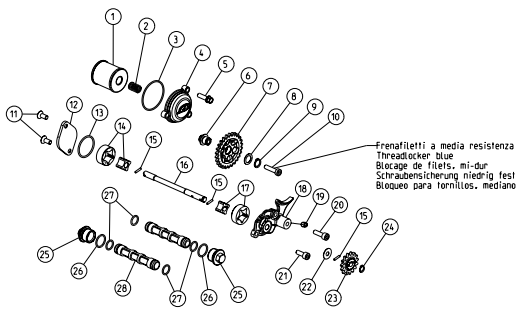

TAV.10 Gruppo accensione elettronica - Electronic ignition assy. - Groupe allumage électronique - Elektronischezündung gruppe - Grupo encendido electrónico

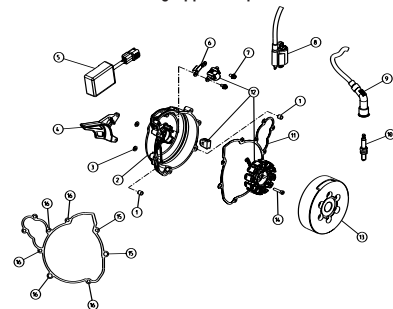

TAV.11A Testa e raccordo d'ammissione - Cylinder head and induction pipe - Culasse et raccord d'admission - Zylinderkopf und Ansaugstutzen - Culata y racor de admision

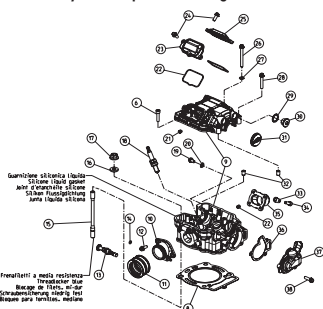

TAV.11B Valvole-Catena distribuzione - Valves-Timing chain - Soupapes-Chaine de distribution - Ventil-Steuerkette - Válvulas-Cadena de distribución

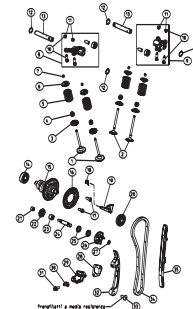

TAV.12 Carburatore - Carburettor - Carburateur - Vergaser - Carburador

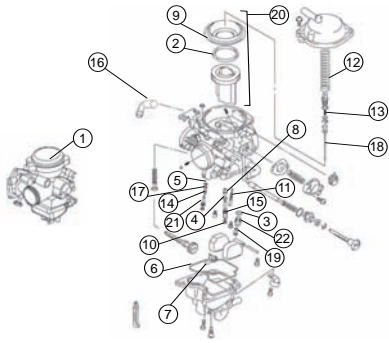

TAV.14 Attrezzatura specifica - Special tools - Outillage spécial - Spezialwerkzeug - Utillaje específico

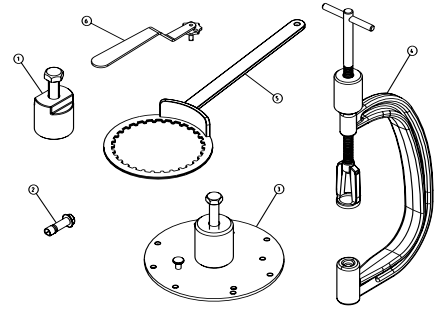

TAV.32 Telaio - Frame - Chassis - Rahmen - Chasis

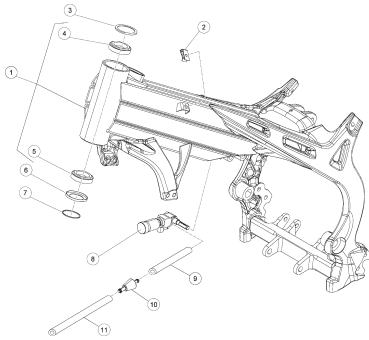

TAV.32 Accessori telaio - Frame accessories - Accessoires chassis - Rahmenzubehören - Accesorios Chasis

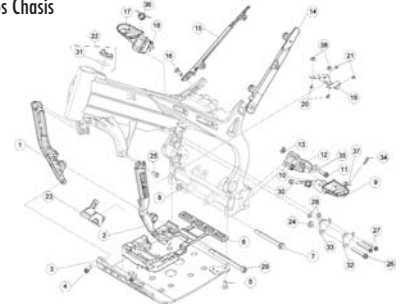

TAV.33 Forcellone posteriore - Rear fork - Fourche arriere - Hinterradschwinge - Horquilla posterior

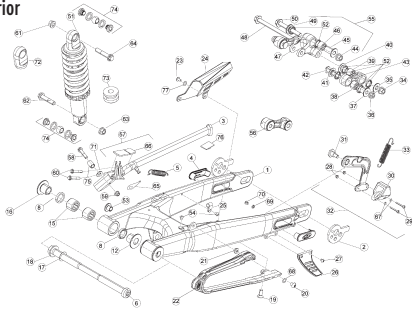

TAV.34 Forcella anteriore - Front fork - Fourche AV - Vorderradgabel - Horquilla delantera

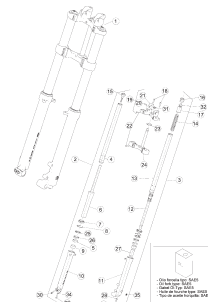

TAV.35 Comandi-Manubrio - Controls-Handlebars - Commandes-Guidon - Bedienungselemente-Lenker - Mandos-Manillar

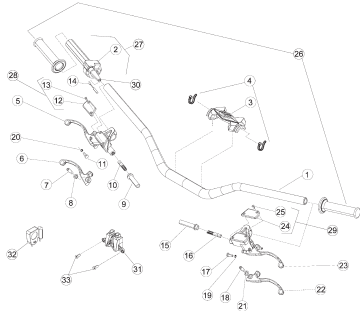

TAV.36 Impianto freni idraulici - Hydraulic brakes system - Installation des freins hydrauliques - Hidraulischebremseanlage - Instalación freno hidráulico

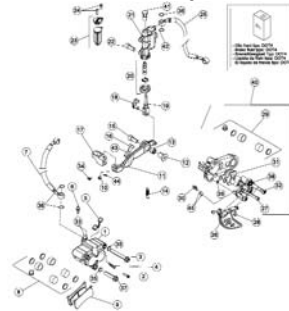

TAV.37 Gruppo scarico - Exhaust system - Echappement - Auspuffanlage - Grupo escape

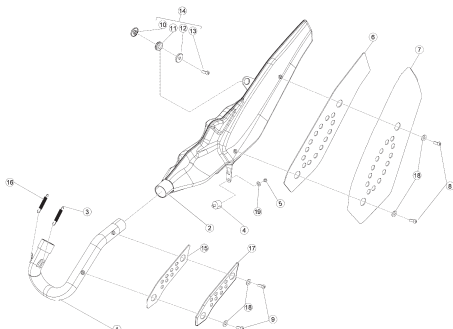

TAV.38 Scatola filtro - Filter box - Boîtier du filtre - Sicherungskasten - Caja del filtro

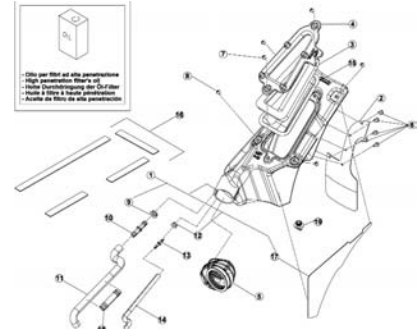

TAV.39 Impianto di raffreddamento - Installation de refroidissement - Installation de refroidissement - Kühlsystem - Instalación de enfriamiento

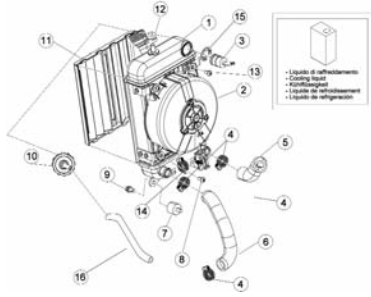

TAV.40 Impianto elettrico - Electrical equipment - Installation électrique - Elektrische anlage - Instalación eléctrica

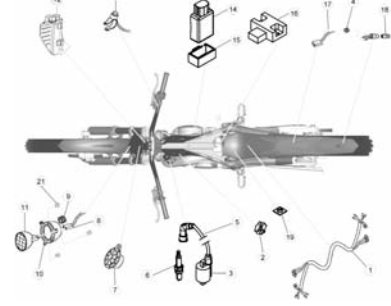

TAV.41 Ruota anteriore - Front wheel - Roue AV. - Vorderrad - Rueda delantera

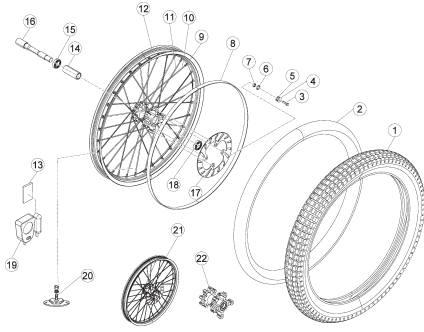

TAV.42 Ruota posteriore - Rear wheel - Roue AR. - Hinterrad - Rueda trasera

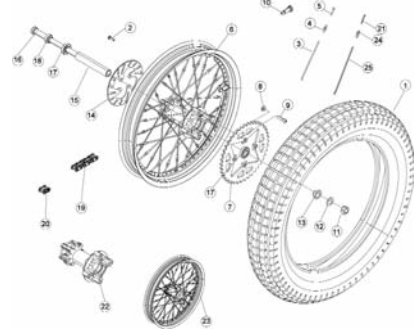

TAV.43 Carenature-Serbatoio-Sella - Fairings-Tank-Saddle - Carenages-Reservoir-Selle - Verkleidungen-Tank-Sattel - Carenados-Deposito-Sillin

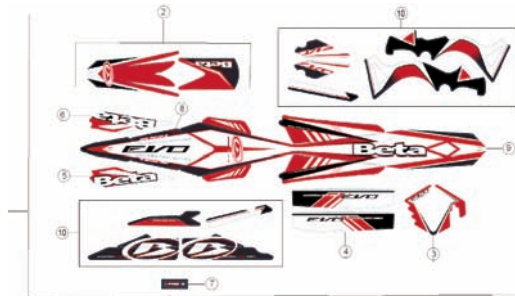



Tav.01

Frenafiletti a media resistenza
 Threadlocker blue
 Blocage de filets, mi-dur
 Schraubensicherung niedrig fest
 Bloqueo para tornillos, mediano

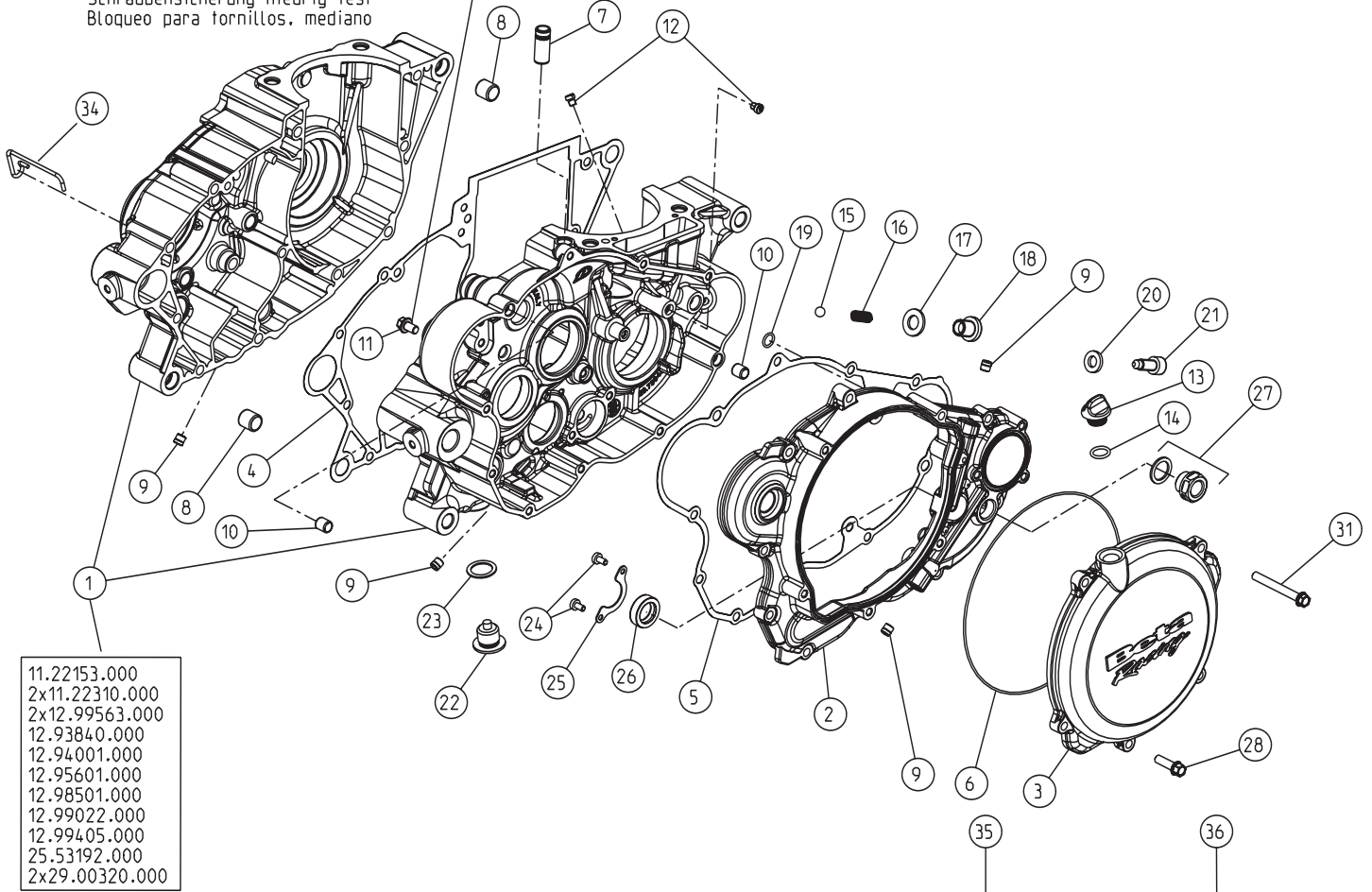

- 11.22153.000
- 2x11.22310.000
- 2x12.99563.000
- 12.93840.000
- 12.94001.000
- 12.95601.000
- 12.98501.000
- 12.99022.000
- 12.99405.000
- 25.53192.000
- 2x29.00320.000

- 16.55734.000
- 16.67211.000
- 16.71683.000
- 16.75133.000
- 001111160 000 250cc
- 001111150 000 300cc

- 2x10.44490.000
- 1052014 000
- 10.52013.000
- 10.58000.000
- 10.64113.000
- 10.64661.000
- 10.64681.000

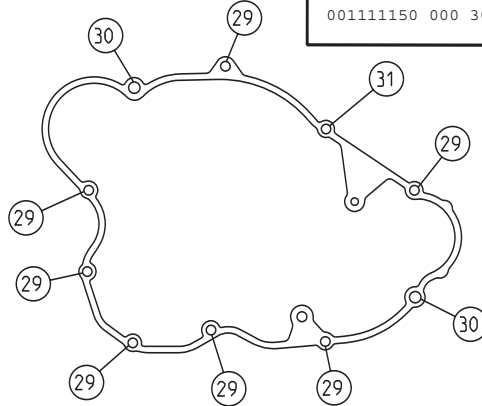
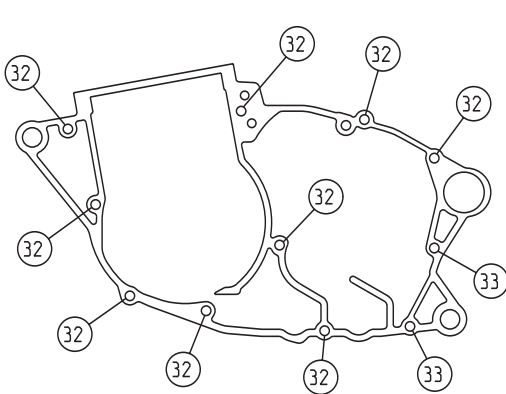

Tav.01

Pos Loc Pos Ps Pos	Numero Number Numéro Número Nummer	Q.tà Q.ty Q.té M.ge C.ad	Nota Note Note Nota Anm.	Descrizione	Description	Désignation	Beschreibung	Descripcìon
1	001013008 000			Carter motore	Crankcase assy	Carter moteur complet	Kurbekgehäuse, kompl.	Carter motor completo
2	1262671 000			Carter frizione	Clutch case	Carter embrayage	Kupplungsgehäuse	Cárter del embrague
3	1263113 000			Coperchio frizione	Clutch cover	Couvercle d'embrayage	Kupplungsdeckel	Tapa embrague
4	1655734 000			Guarnizione carter centrale	Crankcase centre gasket	Joint de carter central	Dichtung hauptgehäuse	Junta central del cárter
5	1671683 000			Guarnizione carter frizione	Clutch casing gasket	Joint de carter d'embrayage	Dichtung kupplungsgehäuse	Junta del cárter del embrague
6	1067341 000			Anello or coperchio frizione esterno	O-ring, outer clutch cover	Bague jt couvercle d'embrayage ext.	O-ring kupplungsdeckel aussen	Anillo o cubierta exterior del embrague
7	1122153 000			Bocchello di ventilazione	Breather nozzle	Orifice de purge	Entlüftungsniessel	Orificio del respiradero
8	1641500 000			Grano di riferimento	Dowel	Repère	Passstift	Centraje
9	2900320 000			Tappo olio ad espansione	Oil expansion plug	Bouchon d'huile à expansion	Öl-expansionsstopfen	Tapón extensible del aceite
10	1636500 000			Grano 9x7,2x10	Dowel 9x7,2x10	Goujon 9x7,2x10	Stift 9x7,2x10	Clavija 9x7,2x10
11	1146501 000			Bullone M6x10	Bolt M6x10	Boulon M6x10	Bolzen M6x10	Tornillo M6x10
12	1642901 000			Getto 0,75	Jet 0,75	Gicleur 0,75	Düse 0,75	Surtidor 0,75
13	2910293 000			Tappo alimentazione olio	Oil plug	Bouchon approv. huile	Öleinfüllstopfen	Tapón aceite alimentación
14	1066164 000			Anello Or 11x2,5 nbr70 sh	Ring 11x2,5 nbr70 sh	Bague d'étanchéité 11x2,5 nbr70 sh	O-Ring 11x2,5 nbr70 sh	Anillo OR 11x2,5 nbr70 sh
15	2890201 000			Sfera ø7	Ball ø7	Bille ø7	Kugel ø7	Bola ø7
16	2234110 000			Molla valvola di max	Spring, oil pressure relief valve	Ressort de soupape	Feder max-ventil	Muelle de válvula de escape
17	2760265 000			Rondella rasamento 12x18x1,5	Thrust washer 12x18x1,5	Rondelle de butée 12x18x1,5	Anlaufscheibe 12x18x1,5	Arandela distanciadora 12x18x1,5
17	2760265 100			Rondella rasamento 12x18x1	Thrust washer 12x18x1	Rondelle de butée 12x18x1	Anlaufscheibe 12x18x1	Arandela distanciadora 12x18x1
18	3165050 000			Vite M12x12 torx	Screw M12x12 torx	Vis M12x12 torx	Schraube M12x12 torx	Tornillo M12x12 torx
19	1066184 000			Anello OR 8,5x1,5 fkn	Ring 8,5x1,5 fkn	Bague d'étanchéité 8,5x1,5 fkn	O-Ring 8,5x1,5 fkn	Anillo OR 8,5x1,5 fkn
20	2758064 000			Rondella rasamento 8,4x16x2,5	Thrust washer 8,4x16x2,5	Rondelle de butée 8,4x16x2,5	Anlaufscheibe 8,4x16x2,5	Arandela distanciadora 8,4x16x2,5
21	3164200 000			Vite M8	Screw M8	Vis M8	Schraube M8	Tornillo M8
22	2900451 000			Tappo scarico olio con calamita	Oil drain plug with magnet	Bouchon vidange huile avec aimant	Verschluß für Ölablaß mit Magnet	Tapón vaciado aceite con imán
23	1653600 000			Guarnizione 16x22,5x1	Packing 16x22,5x1	Joint 16x22,5x1	Dichtung 16x22,5x1	Junta 16x22,5x1
24	3173000 000			Vite speciale M4x8	Special screw M4x8	Vis spéciale M4x8	Spezialschraube M4x8	Tornillo especial M4x8
25	2557658 000			Piastrina fissaggio anello paraolio	Retaining plate, oil seal	Plaque de fixation bague d'étanchéité	Befestigungsplatte wellendichtring	Pastilla de fijación del anillo de retención del aceite
26	1052014 000			Anello paraolio 14x24x7	Oil seal 14x24x7	Joint d'étanchéité 14x24x7	Ölschutzring 14x24x7	Retén de aceite 14x24x7
27	2910031 000			Tappo livello olio	Oil level plug	Bouchon niveau huile	Ölkontrolverschluss	Tapa nivel aceite
28	1149070 000			Bullone 6x20 ch rs	Bolt 6x20 ch rs	Boulon 6x20 ch rs	Bolzen 6x20 ch rs	Tornillo 6x20 ch rs
29	1150010 000			Bullone M6x25	Bolt M6x25	Boulon M6x25	Bolzen M6x25	Tornillo M6x25
30	1150300 000			Bullone 6x30 ch rs	Bolt 6x30 ch rs	Boulon 6x30 ch rs	Bolzen 6x30 ch rs	Tornillo 6x30 ch rs
31	1105540 000			Bullone M6x55 rs ch 8	Bolt M6x55 rs ch 8	Boulon M6x55 rs ch 8	Bolzen M6x55 rs ch 8	Tornillo M6x55 rs ch 8
32	1105485 000			Bullone M6x60 rs ch 8	Bolt M6x60 rs ch 8	Boulon M6x60 rs ch 8	Bolzen M6x60 rs ch 8	Tornillo M6x60 rs ch 8
33	1150535 000			Bullone M6x45 rs ch 8	Bolt M6x45 rs ch 8	Boulon M6x45 rs ch 8	Bolzen M6x45 rs ch 8	Tornillo M6x45 rs ch 8
34	2524584 000			Passacavo tubi sfiato	Breather pipes grommet	Passe-câble tuyaux réinflard	Kabeldurchgang	Pasacables tubos respiraderos
35	2808088 800	250cc		Serie guarnizioni	Set of gaskets	Jeu de joints	Dichtungssatz	Juego de juntas
35	2808093 800	300cc		Serie guarnizioni	Set of gaskets	Jeu de joints	Dichtungssatz	Juego de juntas
36	2808089 800			Serie paraolio	Seal ring set cpl.	Joint spy (jeu complet)	Dichtringssatz Kpl.	Juntas Aceite (juego completo)

Tav.02

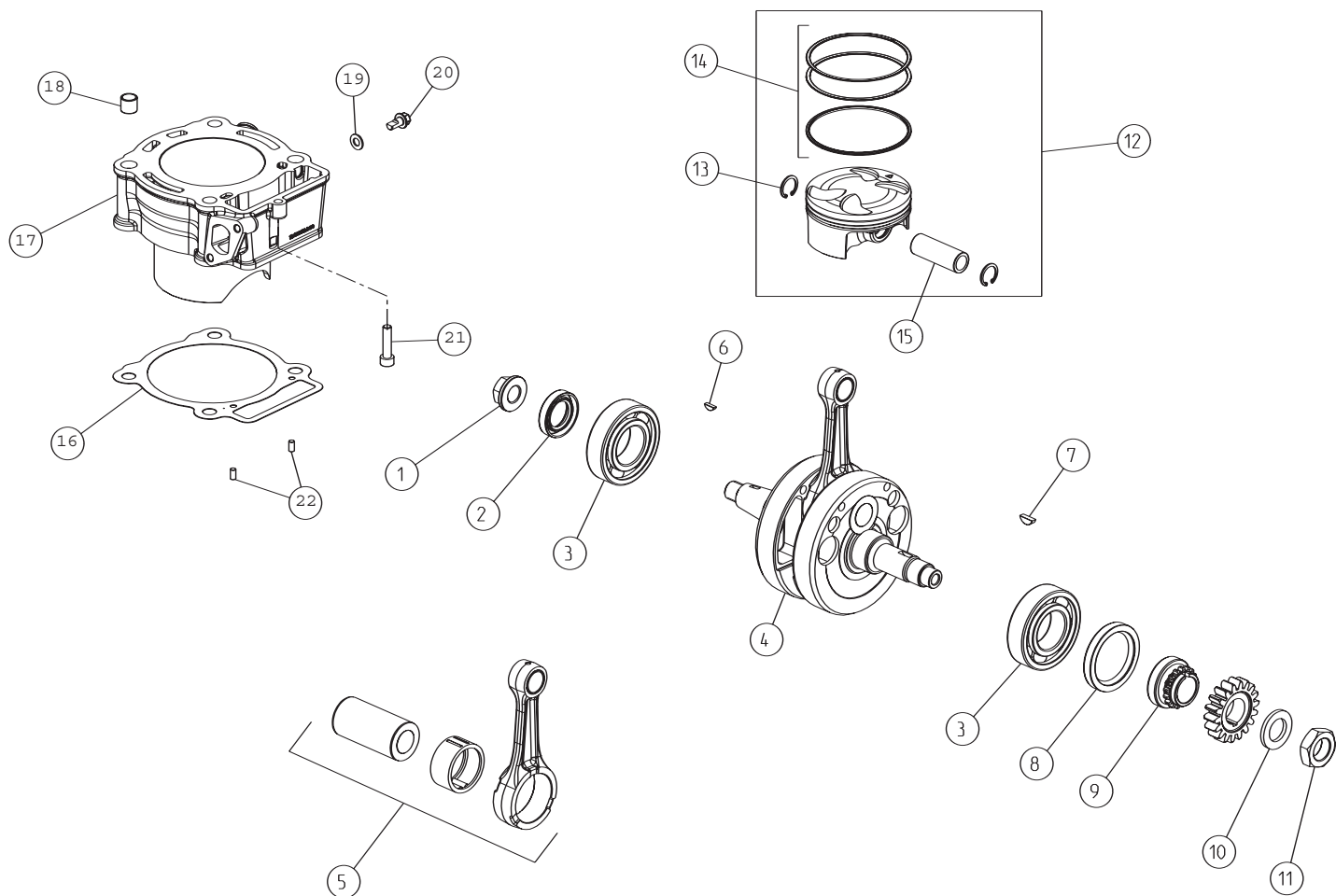

Pos Loc Ps Pos	Numero Number Número Nummer	Q.tà Q.ty Q.té M.ge C.ad	Nota Note Note Nota Anm.	Descrizione	Description	Désignation	Beschreibung	Descripció
1	1322090 000			Dado speciale M14x1,5 ch 19	Special nut M14x1,5 ch 19	Ecrou spéciale M14x1,5 ch 19	Spezialmutter M14x1,5 ch 19	Tuerca especial M14x1,5 ch 19
2	1064661 000			Anello paraolio	Oil seal	Joint d'étanchéité	Ölschutzring	Retén de aceite
3	1299563 000			Cuscinetto 30x62x16 (6206)	Bearing 30x62x16 (6206)	Roulement 30x62x16 (6206)	Lager 30x62x16 (6206)	Cojinetes 30x62x16 (6206)
4	1000715 000			Albero motore completo	Crankshaft, assy.	Arbre moteur complet	kurbelwelle, komplett	Cigüeñal completo
5	1118125 800			Biella completa	Conn.-rod, assy	Bielle compl.	Pleuel, kompl.	Biela compl.
6	1246000 000			Chiavetta	Key	Clavette	Keil	Chaveta
7	1246151 000			Linguetta 4x5 uni 6606	Plate 4x5 uni 6606	Plaque 4x5 uni 6606	Plättchen 4x5 uni 6606	Lengüeta 4x5 uni 6606
8	1064681 000			Anello paraolio 38x52x7	Oil seal 38x52x7	Joint d'étanchéité 38x52x7	Ölschutzring 38x52x7	Retén de aceite 38x52x7
9	1825100 000			Ingranaggio distribuzione	Timing gear	Engrenage distribution	Ventilsteuerzahnrad	Engranaje distribución
10	2772155 000			Rondella rasamento 18x30x3	Thrust washer 18x30x3	Rondelle de butée 18x30x3	Anlaufscheibe 18x30x3	Arandela distanciadora 18x30x3
11	1330331 000			Dado M18x1,5 h9	Nut M18x1,5 h9	Ecrou M18x1,5 h9	Mutter M18x1,5 h9	Tuerca M18x1,5 h9
12	001022508 000	300cc		Pistone completo ø84	Piston set ø84	Piston compl. ø84	Kolben, kompl. ø84	Pistón, compl. ø84
12	2586691 800	250cc		Pistone completo ø77	Piston set ø77	Piston compl. ø77	Kolben, kompl. ø77	Pistón, compl. ø77
13	2824910 000			Seeger j16	Circlip j16	Circlip j16	Seeger j16	Seeger j16
14	2808087 800	250cc		Serie segmenti ø77	Ring set ø77	Serie segments ø77	Set Kolberringe ø77	Serie segmentos ø77
14	2808091 800	300cc		Serie segmenti ø77	Ring set ø77	Serie segments ø77	Set Kolberringe ø77	Serie segmentos ø77
15	2894210 000	250cc		Spinotto per pistone ø77	Piston pin ø77	Axe de piston ø77	Kolbenbolzen ø77	Bulón ø77
15	2894211 000	300cc		Spinotto per pistone ø84	Piston pin ø84	Axe de piston ø84	Kolbenbolzen ø84	Bulón ø84
16	1667211 000			Guarnizione cilindro	Cylinder gasket	Garniture cylindre	Zylinderdichtung	Junta cilindro
17	001022600 000	300cc		Cilindro ø84	Cylinder ø84	Cylindre ø84	Zylinder ø84	Cilindro ø84
17	1251872 000	250cc		Cilindro ø77	Cylinder ø77	Cylindre ø77	Zylinder ø77	Cilindro ø77
18	1640015 000			Grano 12x10	Dowel 12x10	Goujon 12x10	Stift 12x10	Clavija 12x10
19	2758000 000			Rondella	Washer	Rondelle	U.Scheibe	Arandela
20	1147015 000			Bullone M6x12	Bolt M6x12	Boulon M6x12	Bolzen M6x12	Tornillo M6x12
21	3138010 000			Vite t.c.c.e. M6x25	Screw t.c.c.e. M6x25	Vis t.c.c.e. M6x25	Schraube t.c.c.e. M6x25	Tornillo t.c.c.e. M6x25
22	2784126 000			Rullino RC 4x8	Roller RC 4x8	Rouleau RC 4x8	Rolle RC 4x8	Rodillo RC 4x8



Beta
the play bike

Tav.03

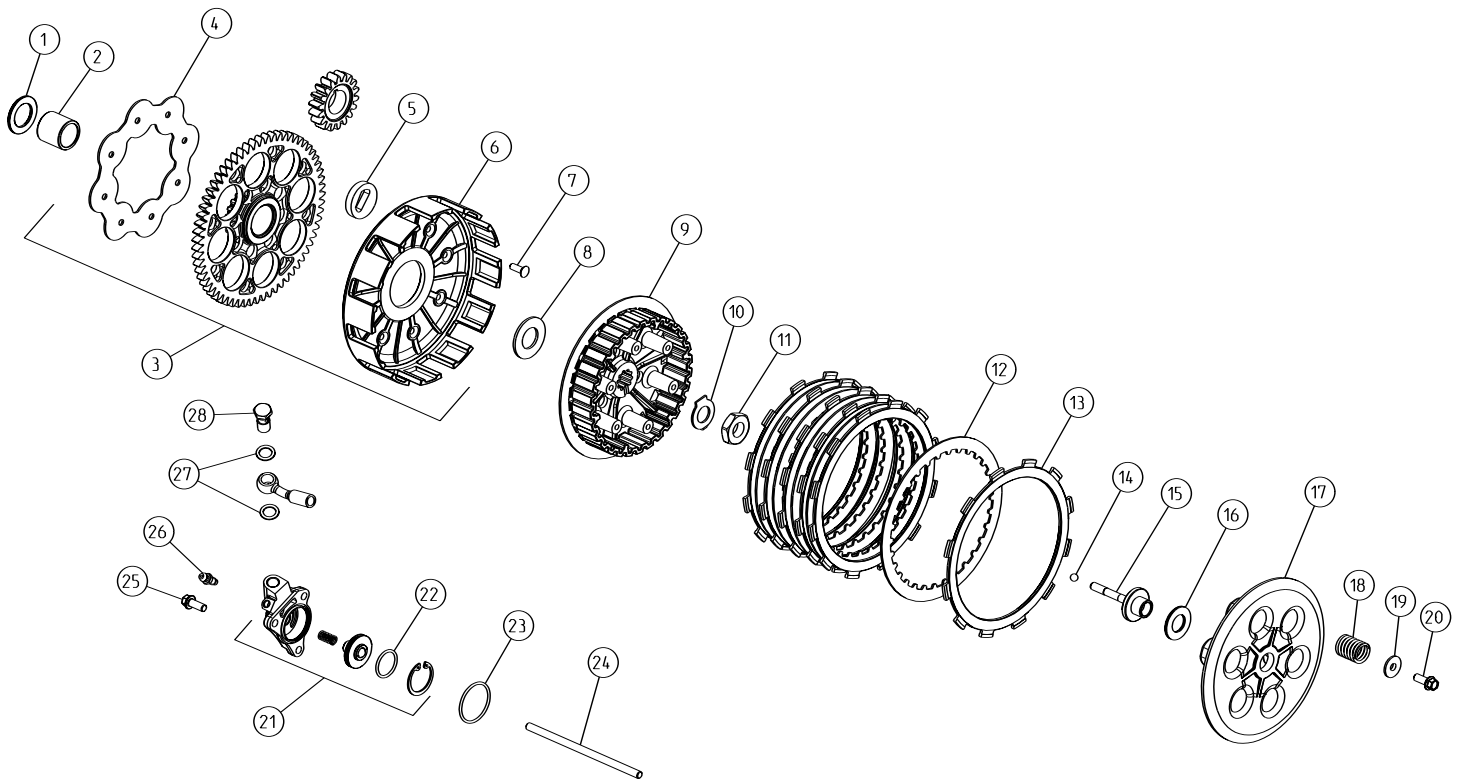

Pos Loc Pos Ps Pos	Numero Number Numéro Número Nummer	Q.tà Q.ty Q.té M.ge C.ad	Nota Note Note Nota Anm.	Descrizione	Description	Désignation	Beschreibung	Descripció
1	2773625 000			Rondella rasamento 20x32x2	Thrust washer 20x32x2	Rondelle de butée 20x32x2	Anlaufscheibe 20x32x2	Arandela distanciadora 20x32x2
2	1122830 000			Boccola 20x25x23,8	Bush 20x25x23,8	Moyeu 20x25x23,8	Büchse 20x25x23,8	Buje 20x25x23,8
3	001031008 000			Trasmissione primaria	Primary drive	Transmission principale	Hauptantrieb	Transmisión primaria
4	1342962 000			Disco ritegno silent-block	Retaining block, silent plate	Disque de retenue du silentbloc	Rückhaltescheibe silentblock	Disco de retención silent block
5	2891840 000			Silent-block frizione	Clutch silentbloc	Silentbloc embrayage	Silentblock Kupplung	Silent-block embrague
6	001031100 000			Campana frizione	Clutch case	Cloche d'embrayage	Kupplungsglocke	Campana de embr.
7	001031110 000			Ribattino 5x18	Rivet 5x18	Rivet 5x18	Niet 5x18	Remache 5x18
8	2765890 000			Rondella speciale	Special washer	Rondelle spéciale	Spezial-Unterlegscheibe	Arandela especial
9	007030100 000			Tamburino frizione	Clutch drum	Noix d'embrayage	Kupplungstrommel	Tambor embrague
10	2774760 000			Rondella fermadado 14	Nut tab washer 14	Rondelle serre-écrou 14	Scheibe mutternsicherung 14	Arandela de empuje tuerca 14
11	1328950 000			Dado speciale 14x1,25x6	Special nut 14x1,25x6	Ecrou spéciale 14x1,25x6	Spezialmutter 14x1,25x6	Tuerca especial 14x1,25x6
12	1338360 000			Disco acciaio	Steel plate	Disque lisse	Stahlscheibe	Disco
13	1343312 000			Disco conduttore	Driving plate	Disque menant	Kup.-streifscheibe	Disco conductor
14	2890210 000			Sfera	Ball	Bille	Kugel	Bola
15	2560410 000			Piattello spingidisco	Spring collar	Godet d'embrayage	Druckteller	Platillo embrague
16	1611370 000			Gabbia reggispinta 15x28x2	Thrust bearing cage 15x28x2	Butée à aiguilles 15x28x2	Andruckkäfig 15x28x2	Jaula cojinete de empuje 15x28x2
17	1229601 000			Cappellotto spingidisco	Pressure plate cap	Plateau de pression	Verschlußkappe Scheibendrucker	Tapa plato de presión
18	2265071 000			Molla frizione	Clutch spring	Ressort embr.	Kupplg.feder	Muelle embr.
19	2742010 000			Rondella speciale	Special washer	Rondelle spéciale	Spezial-Unterlegscheibe	Arandela especial
20	1148025 000			Bullone 6x16 ch 8 rs	Bolt 6x16 ch 8 rs	Boulon 6x16 ch 8 rs	Bolzen 6x16 ch 8 rs	Tornillo 6x16 ch 8 rs
21	1291891 000			Corpo pompa frizione c/pistone	Clutch slave cylinder c/w piston	Corps de pompe d'embrayage avec pist.	Gehäuse kupplungspumpe mit kolben	Protector con pistón de la bomba del embrague
22	1066520 000			Anello OR 23,52X1,78	Ring 23,52X1,78	Bague d'étanchéité 23,52X1,78	O-Ring 23,52X1,78	Anillo OR 23,52X1,78
23	1066700 000			Anello OR 29,32 z1,5	Ring 29,32 z1,5	Bague d'étanchéité 29,32 z1,5	O-Ring 29,32 z1,5	Anillo OR 29,32 z1,5
24	1088258 000			Asta comando frizione	Clutch control rod	Tige de commande embrayage	Kupplungssteuerungsstab	Varilla mando embrague
25	1148025 000			Bullone 6x16 ch 8 rs	Bolt 6x16 ch 8 rs	Boulon 6x16 ch 8 rs	Bolzen 6x16 ch 8 rs	Tornillo 6x16 ch 8 rs
26	2891050 000			Tappo sfiato	Breather plug	Bouchon reniflard	Verschluß Entlüfter	Tapón respiradero
27	1650510 000			Guarnizione 10x15x1 in rame	Gasket 10x15x1 copper	Joint 10x15x1 cuivre	Dichtung 10x15x1 Kupfer	Junta 10.15.1 (cobre)
28	1650510 000			Guarnizione 10x15x1 in rame	Gasket 10x15x1 copper	Joint 10x15x1 cuivre	Dichtung 10x15x1 Kupfer	Junta 10.15.1 (cobre)

Tav.04

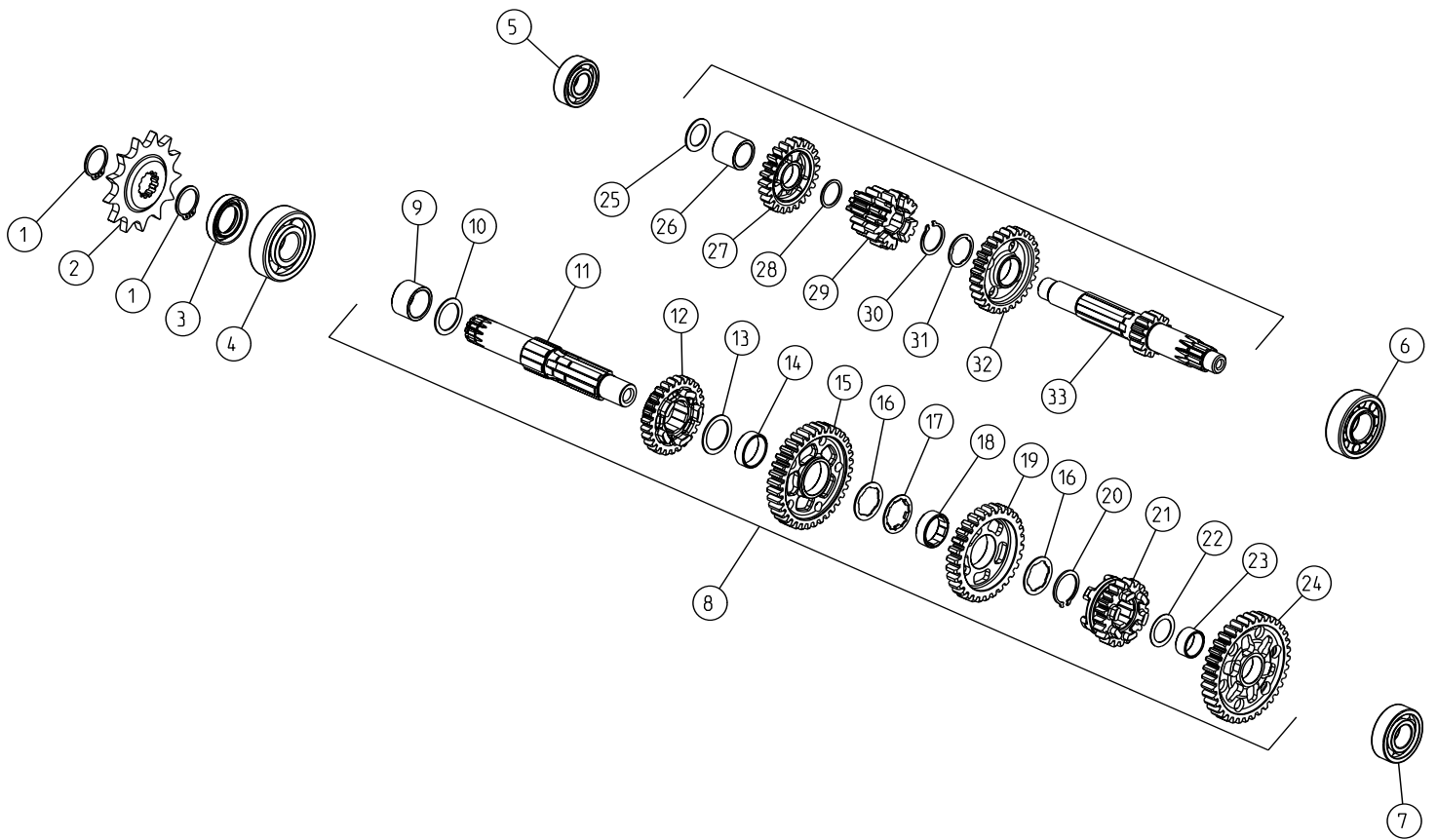

Tav.04

Pos Loc Ps Pos	Numero Number Numéro Número Nummer	Q.tà Q.ty Q.té M.ge C.ad	Nota Note Note Nota Anm.	Descrizione	Description	Désignation	Beschreibung	Descrìcion
1	2825400 000			Seeger 20e	Circlip 20e	Circlip 20e	Seeger 20e	Seeger 20e
2	2560843 000			Pignone Z.11	Pinion Z.11	Pignon Z.11	Ritzel Z.11	Piñón Z.11
3	1064113 000			Anello paraolio 20x35x7	Oil seal 20x35x7	Joint d'étanchéité 20x35x7	Ölschutzring 20x35x7	Retén de aceite 20x35x7
4	1299022 000			Cuscinetto 20x52x15	Bearing 20x52x15	Roulement 20x52x15	Lager 20x52x15	Cojinete 20x52x15
5	1294001 000			Cuscinetto 15x35x11 (6202)	Bearing 15x35x11 (6202)	Roulement 15x35x11 (6202)	Lager 15x35x11 (6202)	Cojinete 15x35x11 (6202)
6	1298501 000			Cuscinetto 20x47x14	Bearing 20x47x14	Roulement 20x47x14	Lager 20x47x14	Cojinete 20x47x14
7	1295601 000			Cuscinetto 17x40x12	Bearing 17x40x12	Roulement 17x40x12	Lager 17x40x12	Cojinete 17x40x12
8	1200740 800			Cambio completo	Transmission, assy	Boîte de vitesses	Getriebe komplett	Cambio completo
9	1355130 000			Distanziale 20x25x15,4	Spacer 20x25x15,4	Entretoise 20x25x15,4	Distanzstück 20x25x15,4	Distanciadore 20x25x15,4
10	2773213 000			Rondella rasamento 20x27x1	Thrust washer 20x27x1	Rondelle de butée 20x27x1	Anlaufscheibe 20x27x1	Arandela distanciadora 20x27x1
11	1029380 800			Albero secondario	Counter shaft	Arbre secondaire	Nebengetriebewelle	Eje secundario
12	1864835 800			Quarta sul secondario	Fourth gear - layshaft	Quatrième sur le secondaire	4. Gang auf abtriebswelle	Cuarta marcha en el cigüeñal sec.
13	2773826 000			Rondella rasamento 22,2x29x1	Thrust washer 22,2x29x1	Rondelle de butée 22,2x29x1	Anlaufscheibe 22,2x29x1	Arandela distanciadora 22,2x29x1
14	1129050 000			Boccola 22x28x8	Bush 22x28x8	Moyeu 22x28x8	Büchse 22x28x8	Buje 22x28x8
15	1853125 800			Seconda sul secondario	Second gear - layshaft	Deuxième sur le secondaire	2. Gang auf abtriebswelle	Segunda marcha en el cigüeñal sec.
16	2773822 000			Rondella scanalata	Splined washer	Rondelle rainurée	Schlitzscheibe	Arandela con ranura
17	2773829 000			Rondella di fermo	Stop washer	Rondelle d'arrêt	Sprengring	Arandela
18	1129051 000			Boccola scanalata 22x20x8,5	Splined bush 22x20x8,5	Douille rainurée 22x20x8,5	Nutbuchse 22x20x8,5	Caja de grasa acanalada 22x20x8,5
19	1858945 800			Terza sul secondario	Third gear - layshaft	Troisième sur le secondaire	3. Gang auf abtriebswelle	Tercera marcha en el cigüeñal sec.
20	2825485 000			Seeger	Circlip	Circlip	Seeger	Seeger
21	1866415 800			Quinta sul secondario	Fifth gear - layshaft	Cinquième sur le secondaire	5. Gang auf abtriebswelle	Quinta marcha en el cigüeñal sec.
22	2773825 000			Rondella rasamento 17x24x0,5	Thrust washer 17x24x0,5	Rondelle de butée 17x24x0,5	Anlaufscheibe 17x24x0,5	Arandela distanciadora 17x24x0,5
23	1129047 000			Boccola 17x20x9,5	Bush 17x20x9,5	Moyeu 17x20x9,5	Büchse 17x20x9,5	Buje 17x20x9,5
24	1843075 800			Prima sul secondario	First gear - layshaft	Première sur le secondaire	1. Gang auf abtriebswelle	Primera marcha en el cigüeñal sec.
25	2764500 100			Rondella rasamento 15x25x1	Thrust washer 15x25x1	Rondelle de butée 15x25x1	Anlaufscheibe 15x25x1	Arandela distanciadora 15x25x1
26	1355131 000			Distanziale 17x22x20,1	Spacer 17x22x20,1	Entretoise 17x22x20,1	Distanzstück 17x22x20,1	Distanciadore 17x22x20,1
27	1837735 800			Quarta sul primario	Fourth gear - mainshaft	Quatrième sur le primaire	4. Gang auf antriebswelle	Cuarta marcha en el cigüeñal prim.
28	2773212 000			Rondella rasamento 17x20,5x1	Thrust washer 17x20,5x1	Rondelle de butée 17x20,5x1	Anlaufscheibe 17x20,5x1	Arandela distanciadora 17x20,5x1
29	1832215 800			Seconda e terza sul primario	Second and third gear - mainshaft	Deuxième et troisième sur le prim.	2. und 3. Gang auf antriebswelle	Seg. y terc. marchas cigüeñal prim.
30	2825465 000			Seeger	Circlip	Circlip	Seeger	Seeger
31	2773821 000			Rondella scanalata	Splined washer	Rondelle rainurée	Schlitzscheibe	Arandela con ranura
32	1838495 800			Quinta sul primario	Fifth gear - mainshaft	Cinquième sur le primaire	5. Gang auf antriebswelle	Quinta marcha en el cigüeñal prim.

Tav.05

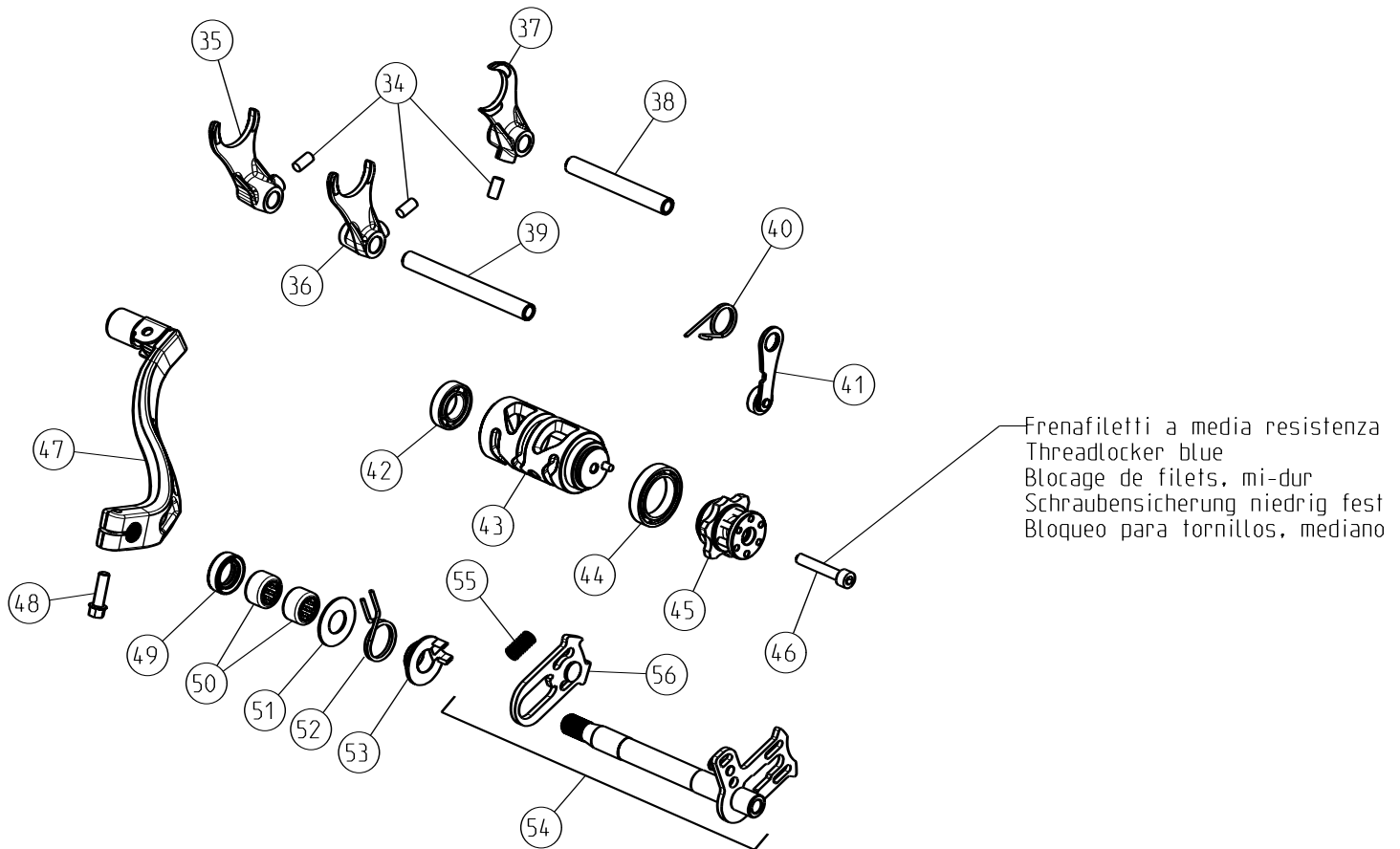

Frenafilletti a media resistenza
Threadlocker blue
Blocage de filets, mi-dur
Schraubensicherung niedrig fest
Bloqueo para tornillos, mediano

Pos Loc Pos Ps Pos	Numero Number Numéro Número Nummer	Q.tà Q.ty Q.té M.ge C.ad	Nota Note Note Nota Anm.	Descrizione	Description	Désignation	Beschreibung	Descripció
33	1023380 800			Albero primario	Mainshaft	Arbre primaire	Hauptwelle	Arbol primario
34	2784110 000			Rullino per forchette 6x12	Peg, selector fork 6x12	Galet pour fourches 6x12	Rolle für gabeln 6x12	Rodillo para las horquillas 6x12
35	1564041 000			Forchetta 2°	Fork 2°	Fourchette 2°	Schaltgabel 2°	Horquilla 2°
36	1564040 000			Forchetta 1°/3°	Fork 1°/3°	Fourchette 1°/3°	Schaltgabel 1°/3°	Horquilla 1°/3°
37	1564042 000			Forchetta 4°/5°	Fork 4°/5°	Fourchette 4°/5°	Schaltgabel 4°/5°	Horquilla 4°/5°
38	2551031 000			Perno forchetta 4°/5°	Spindle, fork 4°/5°	Axe de fourche 4°/5°	Schaltgabelstift 4°/5°	Perno de la horquilla 4°/5°
39	2551030 000			Perno forchetta 1°/2°/3°	Spindle, fork 1°/2°/3°	Axe de fourche 1°/2°/3°	Schaltgabelstift 1°/2°/3°	Perno de la horquilla 1°/2°/3°
40	2239591 000			Molla leva arresto marce	Spring, detent lever	Ressort de levier d'arrêt de vit.	Feder gangarretierhebel	Muelle de palanca de cambio
41	2117014 800			Leva arresto marce	Gear stop lever	Levier arrêt vit.	Gangstoppehebel	Palanca arresto vel.
42	1293840 000			Cuscinetto 15x28x7	Bearing 15x28x7	Roulement 15x28x7	Lager 15x28x7	Cojinete 15x28x7
43	1219693 800			Camma cambio	Selector drum	Barillet de sélection de boîte de vit.	Schaltwalze	Leva de la caja de cambios
44	1299405 000			Cuscinetto 25x37x7	Bearing 25x37x7	Roulement 25x37x7	Lager 25x37x7	Cojinete 25x37x7
45	1219692 800			Camma arresto marce	Gear Stopper Cam	Came Butée Vitesses	Gangsperrnocken	Leva Parada Marchas
46	3148510 000			Vite t.c.c.e M6x35	Screw t.c.c.e M6x35	Vis t.c.c.e M6x35	Schraube t.c.c.e M6x35	Tornillo t.c.c.e M6x35
47	2121151 000			Leva comando cambio	Gearshift lever	Levier de vitese	Schalthebel	Palanca mando cambio
48	1149070 000			Bullone 6x20 ch rs	Bolt 6x20 ch rs	Boulon 6x20 ch rs	Bolzen 6x20 ch rs	Tornillo 6x20 ch rs
49	1052013 000			Anello paraolio 14x24x7	Oil seal 14x24x7	Joint d'étanchéité 14x24x7	Ölschutzring 14x24x7	Retén de aceite 14x24x7
50	1122310 000			Boccola a rulli 14x20x12	Roller bearing 14x20x12	Douille à roulements 14x20x12	Rollenbuchse 14x20x12	Caja de grasa de rodillos 14x20x12
51	2763020 000			Rondella rasamento 14x30x1	Thrust washer 14x30x1	Rondelle de butée 14x30x1	Anlaufscheibe 14x30x1	Arandela distanciadora 14x30x1
52	2272021 000			Molla ritorno comando cambio	Gearchange return spring	Ressort de retour comm. ch.ge vit.	Rückstellfeder schaltung	Muelle de retorno cambio
53	1692911 000			Guida molla	Spring guide	Guide ressort	Federführung	Guia de resorte
54	1013183 000			Albero comando cambio	Gearshift shaft	Arbre de vitese	Schaltwelle	Eje mando cambio
55	2268010 000			Molla ventaglio	Pawl spring	Ressort éventail	Schaltfeder	Muelle del abanico
56	3120981 800			Ventaglio mobile	Movable pawl	Eventail mobile	Schaltautomat	Abanico móvil

Tav.06

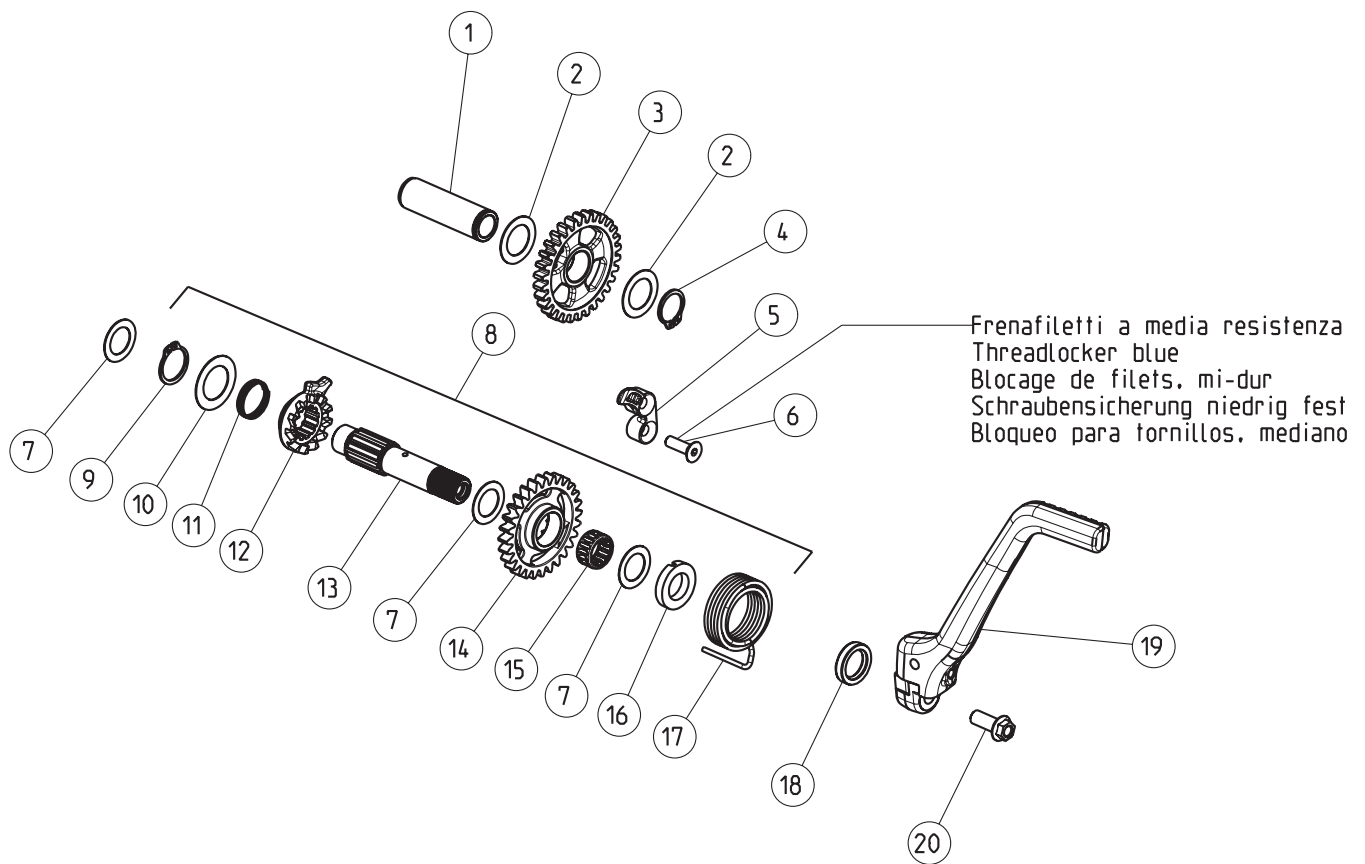

Pos Loc Pos Ps Pos	Numero Number Numéro Número Nummer	Q.tà Q.ty Q.té M.ge C.ad	Nota Note Note Nota Anm.	Descrizione	Description	Désignation	Beschreibung	Descripcìon
1	2553192 000			Perno per ingranaggio rinvio m.m.	Kickstart idler gear shaft	Axe pignon de renvoi démarr.	Stift für Zwinschenrad starter	Perno engr. de reenvio arranque
2	2772560 000			Rondella spessoramento 18x27	Spacer washer 18x27	Entretoise 18x27	Distanzscheibe 18x27	Arandela distanciadora 18x27
3	1867826 000			Ingranaggio rinvio m.m.	Kickstart idler gear	Pignon de renvoi de démarr.	Zwinschenrad starter	Engr. de reenvio arranque
4	2825300 000			Seeger 18E	Circlip 18E	Circlip 18E	Seeger 18E	Seeger 18E
5	1115500 000			Rampa messa in moto	Kickstart ramp	Rampe de démarrage	Startrampe	Rampa para el arranque
6	3134400 000			Vite brugola tspce M6x20	Socket head screw M6x20	Vis allen tspce M6x20	Inbusschraube tspce M6x20	Tornillo de cabeza hexagonal tspce M6x20
7	2767500 050			Rondella rasamento 16x25x0,5	Thrust washer 16x25x0,5	Rondelle de butée 16x25x0,5	Anlaufscheibe 16x25x0,5	Arandela distanciadora 16x25x0,5
8	001062008 000			Messa in moto completa	Kickstart, assy.	Système de démarrage complet	Starter komplett	Arranque completo
9	2825400 000			Seeger 20e	Circlip 20e	Circlip 20e	Seeger 20e	Seeger 20e
10	2773630 000			Rondella spessoramento 20x30x0,5	Spacer washer 20x30x0,5	Entretoise 20x30x0,5	Distanzscheibe 20x30x0,5	Arandela distanciadora 20x30x0,5
11	2236562 000			Molla per manicotto	Spring, Kickstart sleeve	R ressort de manchon	Feder für muffe	Muelle para el manguito
12	2214113 100			Manicotto messa in moto	Kickstart sleeve	Manchon de démarrage	Muffe starter	Manguito arranque
13	001062108 000			Albero messa in moto	Kickstarter shaft	Arbre du démarreur	Starterwelle	Eje puesta en marcha
14	1814633 800			Ingranaggio messa in moto	Kickstart gear	Pignon de démarrage	Startergetriebe	Engranaje del arranque
15	1614300 000			Gabbia 16x20x10	Cage 16x20x10	Cage 16x20x10	Lagerkäfig 16x20x10	Jaula 16x20x10
16	1355232 000			Distanziale messa in moto	Spacer, kickstart	Entretoise démarrage	Distanzstück starter	Distanciadore del arranque
17	2278973 000			Molla ritorno leva m.m.	Kickstart lever return spring	R ressort de retour levier de dem.	Rückstellfeder starterhebel	Muelle de retorno palanca arr.
18	1058000 000			Anello paraolio 16x24x5	Oil seal 16x24x5	Joint d'étanchéité 16x24x5	Ölschutzring 16x24x5	Retén de aceite 16x24x5
19	001063000 000			Leva messa in moto	Start. lever	Lev. du dém.	Kickstarterhebel	Palanca de arranque
20	1154492 000			Bullone 8x20 ch10 rs	Bolt 8x20 ch10 rs	Boulon 8x20 ch10 rs	Bolzen 8x20 ch10 rs	Tornillo 8x20 ch10 rs

Tav.08

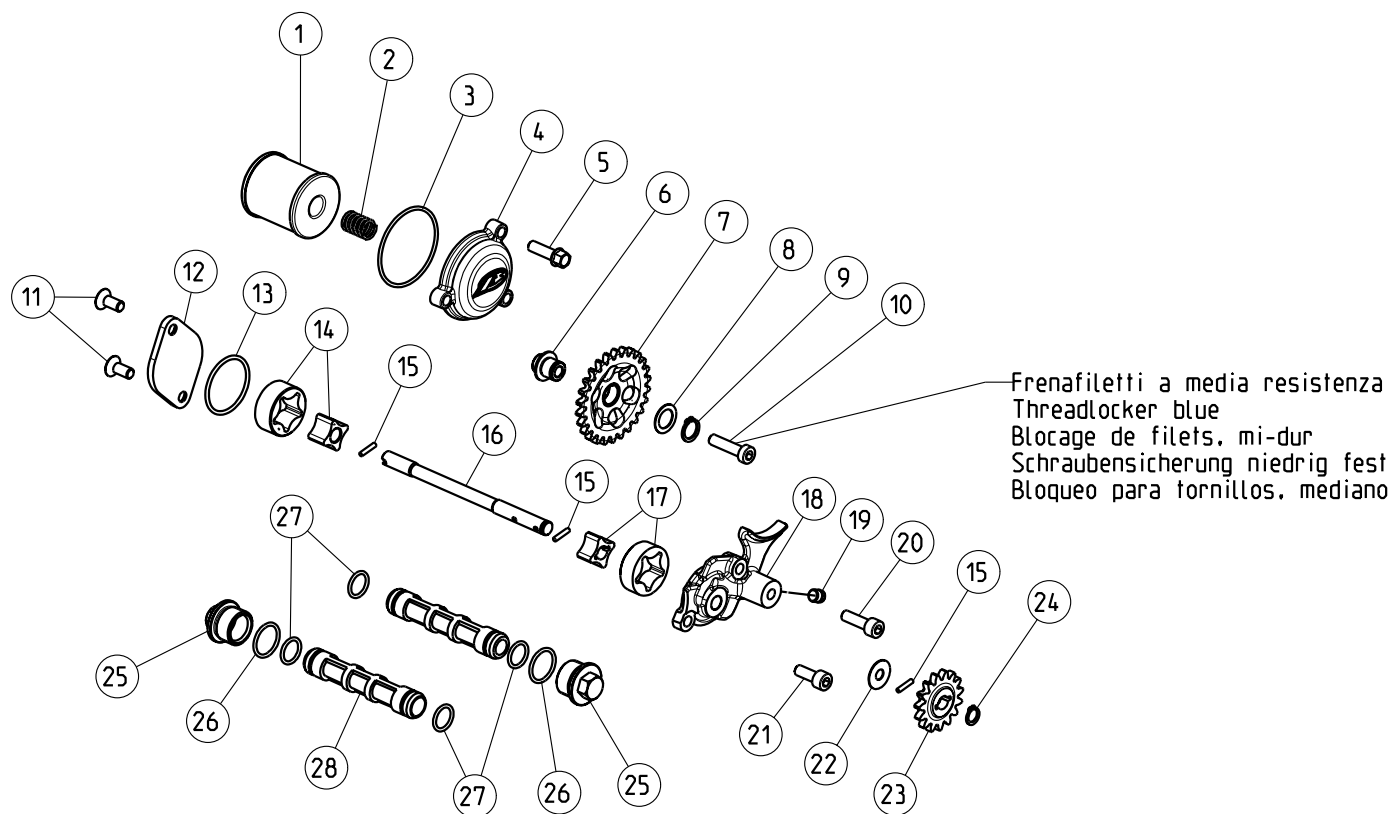

Frenafilletti a media resistenza
Threadlocker blue
Blocage de filets, mi-dur
Schraubensicherung niedrig fest
Bloqueo para tornillos, mediano

Pos Loc Pos Ps Pos	Numero Number Numéro Número Nummer	Q.tà Q.ty Q.té M.ge C.ad	Nota Note Note Nota Anm.	Descrizione	Description	Désignation	Beschreibung	Descripcìon
1	1526060 000			Filtro olio mandata	Oil filter, output	Filtre à huile refolement	Ölfilter vorlauf	Filtro del aceite de descarga
2	2248830 000			Molla filtro olio	Oil filter spring	R ressort filtre à huile	Ölfilterfeder	Muelle filtro de aceite
3	1066932 000			Anello Or 44,17x1,78	Ring 44,17x1,78	Bague d'étanchéité 44,17x1,78	O-Ring 44,17x1,78	Anillo OR 44,17x1,78
4	2910531 000			Tappo filtro mandata	Cover, output oil filter	Bouchon de filtre refolement	Filterstopfen vorlauf	Tapón del filtro de descarga
5	1149070 000			Bullone 6x20 ch rs	Bolt 6x20 ch rs	Boulon 6x20 ch rs	Bolzen 6x20 ch rs	Tornillo 6x20 ch rs
6	2545271 000			Perno rinvio	Pin, idler gear	Goujon de renvoi	Zapfen	Perno de reenvio
7	1882606 800			Ingranaggio di rinvio	Gear	Engrenage	Zahnrad	Engranaje
8	2758600 000			Rondella rasamento 11x17x0,5	Thrust washer 11x17x0,5	Rondelle de butée 11x17x0,5	Anlaufscheibe 11x17x0,5	Arandela distanciadora 11x17x0,5
9	2822720 000			Seeger per albero ø11	Circlip, shaft ø11	Seeger pour arbre ø11	Seegerring für welle ø11	Anillo elástico para el cigüeñal ø11
10	3148507 000			Vite tce testa ribassata M6x25	Screw tce, shallow head M6x25	Vis tce à tête basse M6x25	Schraube tce senkkopf M6x25	Tornillo tce de cabeza rebajada M6x25
11	3130595 000			Vite 6x14 TSPCE	Screw 6x14 TSPCE	Vis 6x14 TSPCE	Schraube 6x14 TSPCE	Tornillo 6x14 TSPCE
12	2910532 000			Tappo pompa olio sx	Cover, oil pump lh	Bouchon de pompe à huile gauche	Ölpumpendeckel links	Tapón de la bomba de aceite sx
13	1066830 000			Anello or 32x2	Ring 32x2	Bague d'étanchéité 32x2	O-Ring 32x2	Anillo OR 32x2
14	2588611 000			Pompa olio h-10	Oil pump h-10	Pompe huile h-10	Ölpumpe h-10	Bomba aceite h-10
15	2784102 000			Rullino rn 2,5x11,8	Roller rn 2,5x11,8	Rouleau rn 2,5x11,8	Rolle rn 2,5x11,8	Rodillo rn 2,5x11,8
16	1027761 000			Albero pompa olio	Oil pump shaft	Arbre de pompe à huile	Ölpumpenwelle	Eje bomba aceite
17	2588610 000			Pompa olio h-12	Oil pump h-12	Pompe huile h-12	Ölpumpe h-12	Bomba aceite h-12
18	2910533 000			Tappo pompa olio dx	Cover, oil pump rh	Bouchon de pompe à huile droite	Ölpumpendeckel rechts	Tapón de la bomba de aceite dx
19	2900320 000			Tappo olio ad espansione	Oil expansion plug	Bouchon d'huile à expansion	Öl-expansionsstopfen	Tapón extensible del aceite
20	3134510 000			Vite t.c.c.e. M6x20	Screw t.c.c.e. M6x20	Vis t.c.c.e. M6x20	Schraube t.c.c.e. M6x20	Tornillo t.c.c.e. M6x20
21	3131050 000			Vite t.c.c.e. M6x15	Screw t.c.c.e. M6x15	Vis t.c.c.e. M6x15	Schraube t.c.c.e. M6x15	Tornillo t.c.c.e. M6x15
22	2758061 050			Rondella rasamento 8,2x15x0,5	Thrust washer 8,2x15x0,5	Rondelle de butée 8,2x15x0,5	Anlaufscheibe 8,2x15x0,5	Arandela distanciadora 8,2x15x0,5
23	1881011 000			Ingranaggio pompa olio	Oil pump gear	Engrenage pompe huile	Zahnrad Ölpumpe	Engranaje bomba aceite
24	2822652 000			Seeger per albero ø8	Circlip, shaft ø8	Seeger pour arbre ø8	Seegerring für welle ø8	Anillo elástico para el cigüeñal ø8
25	3625357 000			Tappo M20x1,5 ch 13	Plug M20x1,5 ch 13	Bouchon M20x1,5 ch 13	Verschluß M20x1,5 ch 13	Tapón M20x1,5 ch 13
26	1066321 000			Or 17,17x1,78	O-ring, plug screw 17,17x1,78	Or 17,17x1,78	O-Ring 17,17x1,78	Or 17,17x1,78
27	1066295 000			Or 12,42x1,78	O-ring, plug screw 12,42x1,78	Or 12,42x1,78	O-Ring 12,42x1,78	Or 12,42x1,78
28	3625356 000			Filtro olio 15x83	Oil filter 15x83	Filtre à huile 15x83	Ölfilter 15x83	Filtro de aceite 15x83



Beta
the play bike

Tav.10

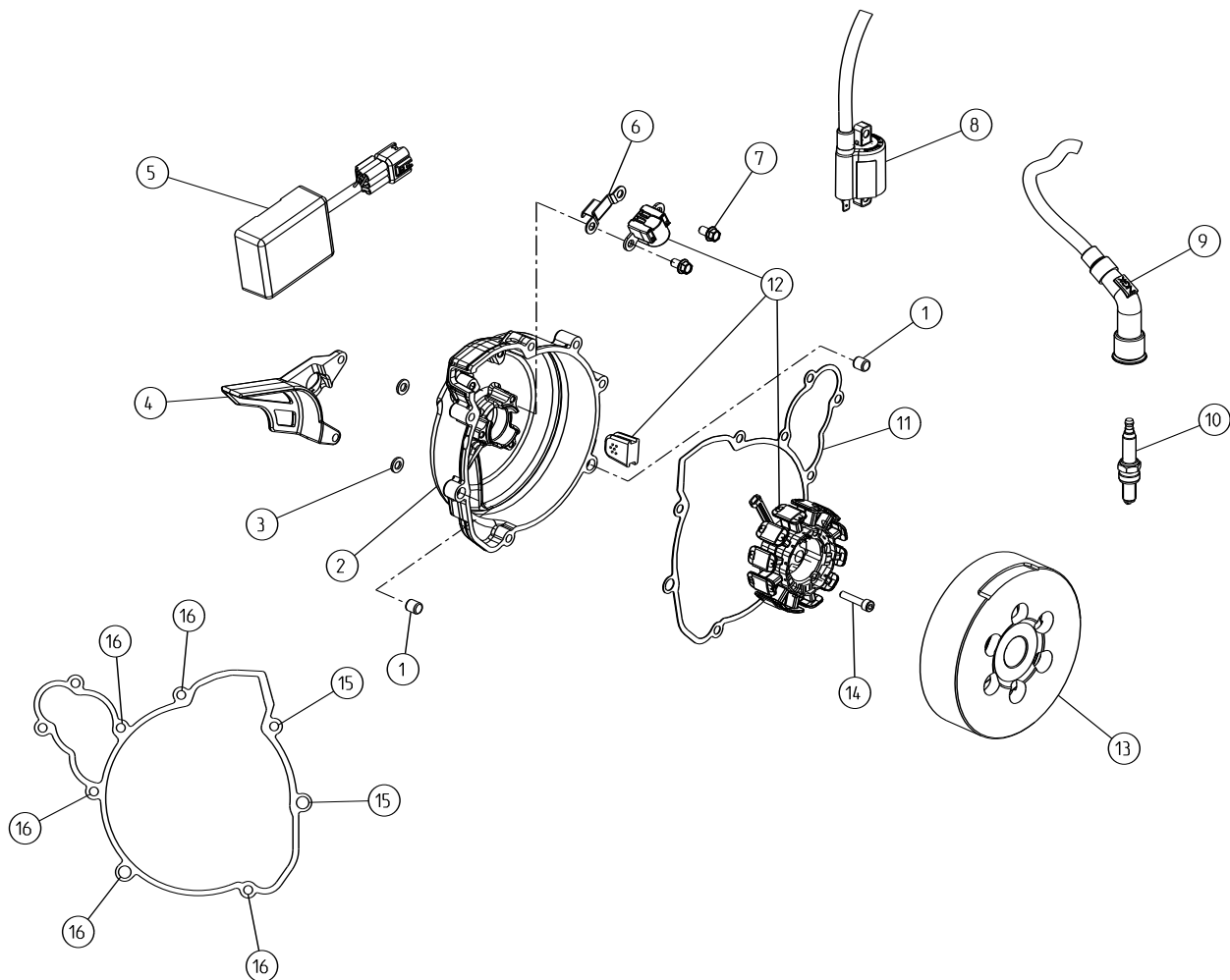

Pos Loc Pos Ps Pos	Numero Number Numéro Número Nummer	Q.tà Q.ty Q.té M.ge C.ad	Nota Note Note Nota Anm.	Descrizione	Description	Désignation	Beschreibung	Descripció
1	1636500 000			Grano 9x7,2x10	Dowel 9x7,2x10	Goujon 9x7,2x10	Stift 9x7,2x10	Clavija 9x7,2x10
2	1269715 000			Coperchio volano	Flywheel cover	Carter volant	Schwungraddeckel	Tapa volante
3	2740500 000			Rondella 6x13	Washer 6x13	Rondelle 6x13	U.Scheibe 6x13	Arandela 6x13
4	1267921 000			Coperchio pignone	Sprocket cover	Couvercle pignon	Deckel Ritzel	Tapa piñón
5	008101110 000	300cc		Centralina digitale	CDI unit	Bobine digital (C.D.I.)	Steuergerät	Centralita digital
5	008100110 000	250cc		Centralina digitale	CDI unit	Bobine digital (C.D.I.)	Steuergerät	Centralita digital
6	2557659 000			Piastrina contenimento fili	Cable retainer plate	Plaque de fixation des fils	Kabelhalteplatte	Pastilla para la contención de los cables
7	1147015 000			Bullone M6x12	Bolt M6x12	Boulon M6x12	Bolzen M6x12	Tornillo M6x12
8	1120681 000			Bobina	Coil	Bobine	Spule	Bobina
9	2713500 000			Raccordo candela	Plug fitting	Raccord bougie	Kerzenanschluß	Racor bujía
10	1225195 000			Candela	Spark plug	Bougie	Zündkerze	Bujía
11	1675133 000			Guarnizione coperchio volano	Alternator cover gasket	Garniture couvercle alternateur	Alternatordeckeldichtung	Junta tapa alternador
12	001101100 000			Statore volano	Alternator stator	Stator volant	Stator schwungrad	Placa del volante
13	001101110 000			Rotore volano	Flywheel rotor	Rotor volant	Rotor volant	Rotor volante
14	3130020 000			Vite M5x25 TCCE	Screw M5x25 TCCE	Vis M5x25 TCCE	Schraube M5x25 TCCE	Tornillo M5x25 TCCE
15	1150355 000			Bullone M6x35	Bolt M6x35	Boulon M6x35	Bolzen M6x35	Tornillo M6x35
16	1150300 000			Bullone 6x30 ch rs	Bolt 6x30 ch rs	Boulon 6x30 ch rs	Bolzen 6x30 ch rs	Tornillo 6x30 ch rs

Tav.11A

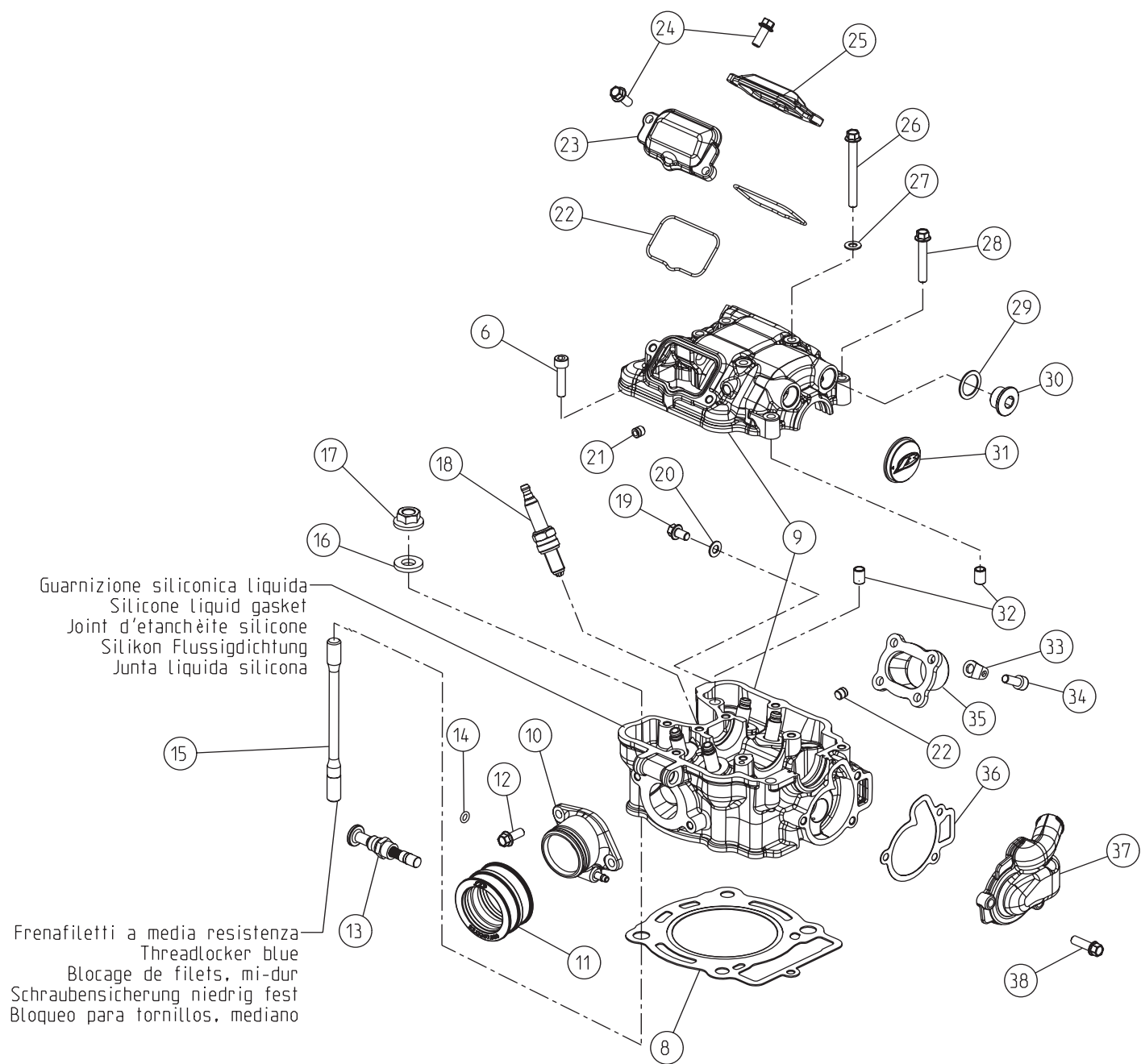

Beta
the play bike

Tav.11A

Pos Loc Pos Ps Pos	Numero Number Numéro Número Nummer	Q.tà Q.ty Q.té M.ge C.ad	Nota Note Note Nota Anm.	Descrizione	Description	Désignation	Beschreibung	Descripción
6	3138010 000			Vite t.c.c.e. M6x25	Screw t.c.c.e. M6x25	Vis t.c.c.e. M6x25	Schraube t.c.c.e. M6x25	Tornillo t.c.c.e. M6x25
8	001111150 000		300cc	Guarnizione	Packing	Joint	Dichtung	Junta
8	001111160 000		250cc	Guarnizione	Packing	Joint	Dichtung	Junta
9	1268952 000			Testa Completa	Cylinder head	Culasse complete	Zylinderkopf Kpl.	Culata completa
10	2723495 800			Raccordo carburatore	Carburettor Union	Raccord Carburateur	Vergaseranschluss	Empalme Carburador
11	2213207 000			Manicotto carburatore	Manifold carburettor	Manchon carburateur	Muffe Vergaser	Manguito carburador
12	1148025 000			Bullone 6x16 ch 8 rs	Bolt 6x16 ch 8 rs	Boulon 6x16 ch 8 rs	Bolzen 6x16 ch 8 rs	Tornillo 6x16 ch 8 rs
13	3102150 000			Valvola "Hot start"	"Hot start" Valve	Valve "Hot start"	Ventil "Hot start"	Válvula "Hot start"
14	1067051 000			Anello or 1,78x5,28	Ring 1,78x5,28	Bague d'étanchéité 1,78x5,28	O-Ring 1,78x5,28	Anillo OR 1,78x5,28
15	2598450 000			Prigioniero	Stud	Goujon	Stiftschraube	Espárrago
16	2758505 000			Rondella rasamento 10,2x21x3	Thrust washer 10,2x21x3	Rondelle de butée 10,2x21x3	Anlaufscheibe 10,2x21x3	Arandela distanciadora 10,2x21x3
17	1320210 000			Dado speciale M10x1,25 ch 13	Special nut M10x1,25 ch 13	Ecrou spéciale M10x1,25 ch 13	Spezialmutter M10x1,25 ch 13	Tuerca especial M10x1,25 ch 13
18	1225195 000			Candela	Spark plug	Bougie	Zundkerze	Bujia
19	1147015 000			Bullone M6x12	Bolt M6x12	Boulon M6x12	Bolzen M6x12	Tornillo M6x12
20	2758000 000			Rondella	Washer	Rondelle	U.Scheibe	Arandela
21	2900320 000			Tappo olio ad espansione	Oil expansion plug	Bouchon d'huile à expansion	Öl-expansionsstopfen	Tapón extensible del aceite
22	1066940 000			Anello or 50,52x1,78	Ring 50,52x1,78	Bague d'étanchéité 50,52x1,78	O-Ring 50,52x1,78	Anillo OR 50,52x1,78
23	1268910 059			Coperchio valvole aspirazione	Intake valve cover	Couvercle soupapes d'aspiration	Einslaßventildeckel	Tapa válvulas de aspiración
24	1148025 000			Bullone 6x16 ch 8 rs	Bolt 6x16 ch 8 rs	Boulon 6x16 ch 8 rs	Bolzen 6x16 ch 8 rs	Tornillo 6x16 ch 8 rs
25	1268911 059			Coperchio valvole scarico	Exhaust valve cover	Couvercle soupapes d'échappement	Auslaßventildeckel	Tapa válvulas de escape
26	1105540 000			Bullone M6x55 rs ch 8	Bolt M6x55 rs ch 8	Boulon M6x55 rs ch 8	Bolzen M6x55 rs ch 8	Tornillo M6x55 rs ch 8
27	2758000 000			Rondella	Washer	Rondelle	U.Scheibe	Arandela
28	1150355 000			Bullone M6x35	Bolt M6x35	Boulon M6x35	Bolzen M6x35	Tornillo M6x35
29	1653600 000			Guarnizione 16x22,5x1	Packing 16x22,5x1	Joint 16x22,5x1	Dichtung 16x22,5x1	Junta 16x22,5x1
30	2910528 000			Tappo sede bilanciata	Racker track cap	Bouchon siege balancier	Kipphebelsitz deckel	Tapón cazoleta balancin
31	2910527 000			Tappo	Plug	Bouchon	Verschluß	Tapón
32	1636300 000			Grano 8x6	Dowel 8x6	Goujon 8x6	Stift 8x6	Clavija 8x6
33	2557912 000			Piastrina fissaggio molla collettore	Retaining plate, manifold spring	Plaque de fixation ressort de coll.	Befestigungsplatte krümmerfeder	Pastilla de fijación del muelle colector
34	3131050 000			Vite t.c.c.e.M6x15	Screw t.c.c.e.M6x15	Vis t.c.c.e.M6x15	Schraube t.c.c.e.M6x15	Tornillo t.c.c.e.M6x15
35	001111300 000			Bocchettone di scarico	Exhaust pipe socket	Tubulure d'échappement	Saugrohrstutzen Auslaß	Tubuladura tubo descarga
36	1674960 000			Guarnizione coperchio	Cover gasket	Joint couvercle	Dichtung Deckel	Junta tapa
37	1267932 000			Coperchio pompa	Pump cover	Couvercle pompe	Pumpendeckel	Tapa bomba
38	1149070 000			Bullone 6x20 ch rs	Bolt 6x20 ch rs	Boulon 6x20 ch rs	Bolzen 6x20 ch rs	Tornillo 6x20 ch rs

Tav.11B

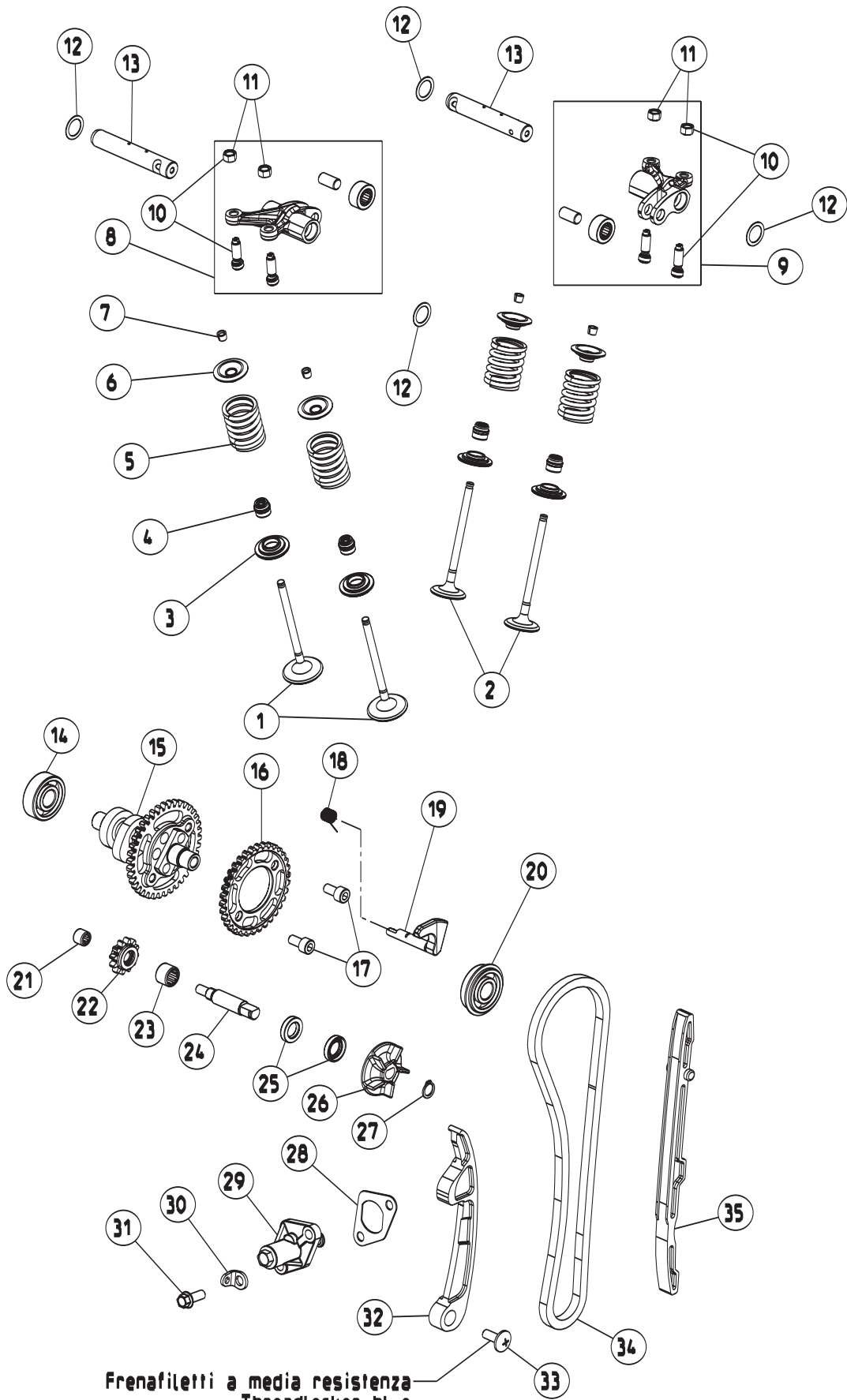

Frenafilotti a media resistenza
 Threadlocker blue
 Blocage de filets, mi-dur
 Schraubensicherung niedrig fest
 Bloqueo para tornillos, mediano

Tav.11B

Pos Loc Pos Ps Pos	Numero Number Numéro Número Nummer	Q.tà Q.ty Q.té M.ge C.ad	Nota Note Note Nota Anm.	Descrizione	Description	Désignation	Beschreibung	Descripcìon
1	3113600 000			Valvola di aspirazione	Valve, in	Soupape d'admission	Ein. Ventil	Valvula de admision
2	3113601 000			Valvola di scarico	Exhaust valve	Soupape d'échapp.	Auslassventil	Válvula de descarga
3	2816825 000			Scodellino inferiore	Lower stop washer	Rondelle d'arrêt inférieure	Unterer Federaufnahme	Platillo inferior
4	2725701 000			Raschiavalvole	Valveguide oilseal	Joint de la tige de soupape	Ventilabstreifer	Funda de las válvulas
5	2234111 000			Molla	Spring	Ressort	Feder	Muelle
6	2816824 000			Scodellino superiore	Upper stop washer	Rondelle d'arrêt supérieure	Oberer Federaufnahme	Platillo superior
7	2878800 000			Semicono	Cone, half	Demi bague	Buchse halb	Semicasquillo
8	1120200 800			Bilanciere lato aspirazione	Equalizer intake side	Culbuteur côté admission	Schwinghebel Einlassseite	Balancin lado admisiòn
9	1120210 800			Bilanciere lato scarico	Equalizer exhaust side	Culbuteur côté échappement	Schwinghebel Auslassseite	Balancin lado escape
10	2726100 000			Registro a vite	Screw adjuster	Règlage à vis	Einstellschraube	Registro a tornillos
11	1320030 000			Dado di registro	Adjuster nut	Écrou de réglage	Stellmutter	Tuerca de registro
12	2759909 000			Rondella rasamento 12x17x0,5	Thrust washer 12x17x0,5	Rondelle de butée 12x17x0,5	Anlaufscheibe 12x17x0,5	Arandela distanciadora 12x17x0,5
13	2254550 000			Perno bilanciere scarico/aspirazione	Rocker spindle, inlet/exhaust	Axe culbuteur éch./adm.	Stift kippshebel auslass/einlass	Perno del balancin de escape o admisiòn
14	1293501 000			Cuscinetto 12x32x10 (6201)	Bearing 12x32x10 (6201)	Roulement 12x32x10 (6201)	Lager 12x32x10 (6201)	Cojinete 12x32x10 (6201)
15	1039000 000			Albero a camme	Camshaft	Arbre à Cames	Nockenwelle	Eje de excéntricas
16	1291400 000			Corona distribuzione (z=34)	Timing gear (z=34)	Couronne distribution (z=34)	Zahnkranz Ventilsteuerung (z=34)	Corona distribuciòn (z=34)
17	3130200 000			Vite brugola tcca M6x10	Socket head screw M6x10	Vis allen tcca M6x10	Inbusschraube tcca M6x10	Tornillo de cabeza hexagonal tcca M6x10
18	2247150 000			Molla decompressore	Decompressor spring	Ressort décompression	Feder dekompessor	Muelle de descompresión
19	2222900 000			Massa decompressore	Decompressor weight	Masse décompression	Masse dekompessor	Masa de descompresión
20	1293502 000			Cuscinetto 12x32x10 (6201nr)	Bearing 12x32x10 (6201nr)	Roulement 12x32x10 (6201nr)	Lager 12x32x10 (6201nr)	Cojinete 12x32x10 (6201nr)
21	1122058 000			Boccola a rulli 6x10x8 hk	Roller bearing 6x10x8 hk	Douille à roulements 6x10x8 hk	Rollenbuchse 6x10x8 hk	Caja de grasa de rodillos 6x10x8 hk
22	1882650 000			Ingranaggio pompa acqua	Water pump gear	Engrenage pompe eau	Zahnrad Wasserpumpe	Engranaje bomba agua
23	1122100 000			Boccola a rulli 10x14x10	Roller bearing 10x14x10	Douille à roulements 10x14x10	Rollenbuchse 10x14x10	Caja de grasa de rodillos 10x14x10
24	1027771 000			Albero pompa acqua	Coolant punp shaft	Arbre de pompe a eau	Wasserpumpenwelle	Eje bomba de agua
25	3625043 000			Anello paraolio 10x18x4	Oil seal 10x18x4	Joint d'étanchéité 10x18x4	Ölschutzring 10x18x4	Retén de aceite 10x18x4
26	1620900 000			Girante pompa acqua	Water pump fan	Couronne pompe eau	Läuferrad der Wasserpumpe	Rotor bomba agua
27	2822660 000			Seeger per albero ø9	Circlip, shaft ø9	Seeger pour arbre ø9	Seegerring für welle ø9	Anillo elástico para el cigüeñal ø9
28	00111640 000			Guarnizione tendi catena	Gasket, camchain tensioner	Joint tendeur de chaîne	Dichtung kettenspanner	Junta del tensor de la cadena
29	2911920 000			Tendicatena (tks4)	Chain tightener (tks4)	Tend. de ch. (tks4)	Kettenspanner (tks4)	Tens. de cad. (tks4)
30	2557912 000			Piastrina fissaggio molla collettore	Retaining plate, manifold spring	Plaque de fixation ressort de coll.	Befestigungsplatte krümmerfeder	Pastilla de fijaciòn del muelle colector
31	1148025 000			Bullone 6x16 ch 8 rs	Bolt 6x16 ch 8 rs	Boulon 6x16 ch 8 rs	Bolzen 6x16 ch 8 rs	Tornillo 6x16 ch 8 rs
32	2525551 000			Pattino mobile	Movable guide	Patin mobile	Gleitstück	Zapata móvil
33	3130530 000			Vite M6x12 TTLIC	Screw M6x12 TTLIC	Vis M6x12 TTLIC	Schraube M6x12 TTLIC	Tornillo M6x12 TTLIC
34	1206450 000			Catena	Chain	Chaîne	Kette	Cadena
35	2525550 000			Pattino fisso	Fixed pad	Patin fixe	Fester Laufschuh	Patin fijo

Tav.12

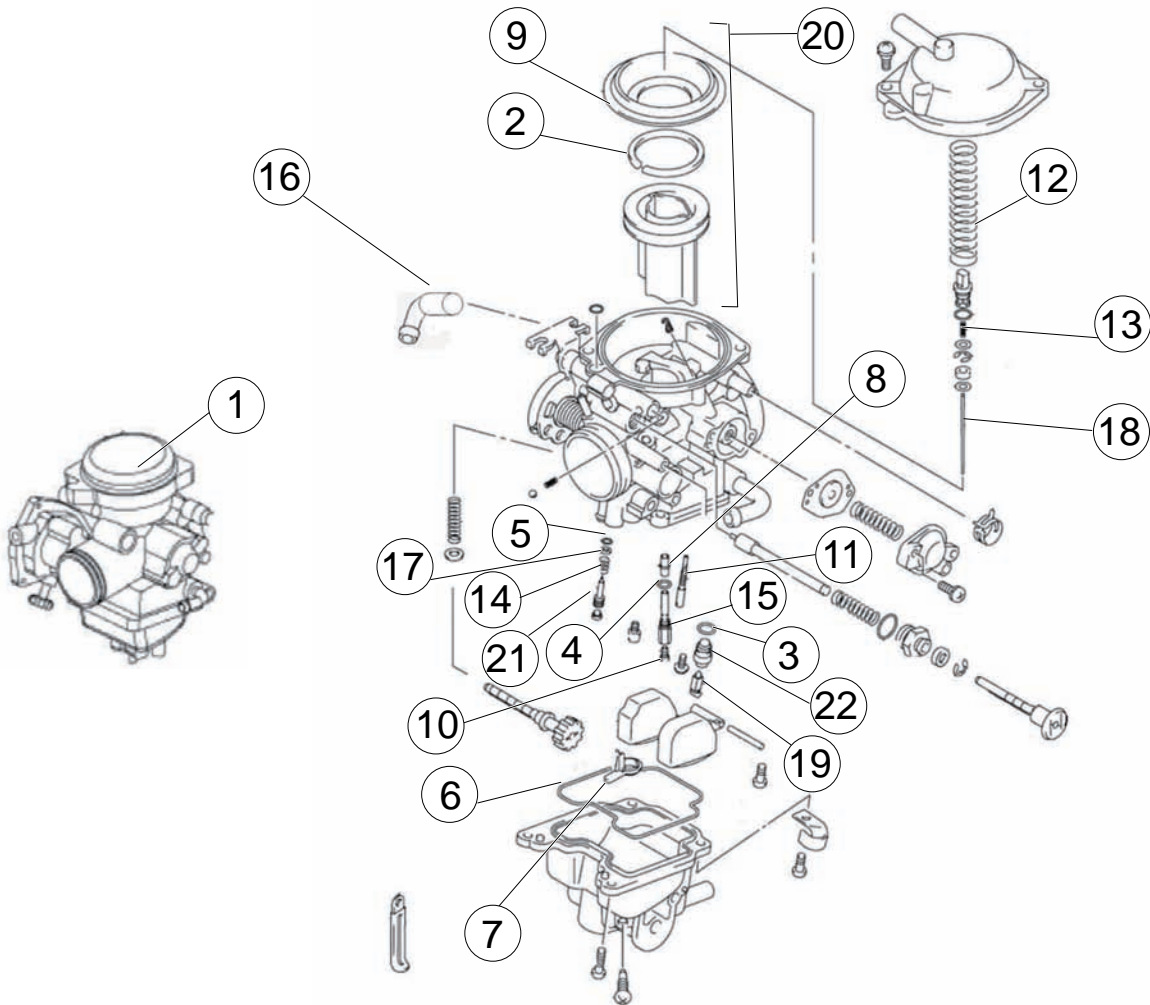

Tav.12

Pos Loc Pos Ps Pos	Numero Number Numéro Número Nummer	Q.tà Q.ty Q.té M.ge C.ad	Nota Note Nota Anm.	Descrizione	Description	Désignation	Beschreibung	Descrìcion
1	001120008 000		250cc	Carburatore 250cc	Carburettor 250cc	Carburateur 250cc	Vergaser 250cc	Carburador 250cc
1	001121008 000		300cc	Carburatore 300cc	Carburettor 300cc	Carburateur 300cc	Vergaser 300cc	Carburador 300cc
2	1042660 000			Anello fissaggio membrana	Diaphragm clamping ring	Bague calage membrane	Klemmring Membran	Anillo de apriete membrana
3	1042661 000			Anello or sede ingranaggio	Gear seat O-Ring	Bague d'étanchéité siège engrenage	O-Ring Zahnradsitz	Anillo OR asiento del engranaje
4	1042662 000			Anello OR polverizzatore	Nozzle O-Ring	Bague d'étanchéité pulvériseur	O-Ring Verstäuber	Anillo OR pulverizador
5	1042663 000			Anello OR vite registro miscela minimo	O-Ring, idling mixture adj. Screw	Bague d'étanchéité, vis réglage mélange de ralenti	O-Ring Regulierschraube	Anillo OR tornillo regulación mezcla relenti
6	1042664 000			Anello or vaschetta	Float chamber O-Ring	Bague d'étanchéité cuvette	O-Ring Vergaserschüssel	Anillo OR recipiente carburador
7	1042665 000			Anello	Ring	Circlips	Ring	Anillo
8	1091150 000			Atomizzatore	Atomizer	Atomiseur	Zerstäuber	Pulverizador
9	1336150 000			Diaphragma	Diaphragm	Diaphragme	Zwischenwand	Diafragma
10	1642096 000			Getto massimo 112,5	Main jet 112,5	Gicleur maxi 112,5	Hauptdüse 112,5	Surtidor máximo 112,5
10	1642097 000			Getto massimo 115	Main jet 115	Gicleur maxi 115	Hauptdüse 115	Surtidor máximo 115
10	1642098 000			Getto massimo 117,5	Main jet 117,5	Gicleur maxi 117,5	Hauptdüse 117,5	Surtidor máximo 117,5
10	1642094 000			Getto massimo 120	Main jet 120	Gicleur maxi 120	Hauptdüse 120	Surtidor máximo 120
10	1642095 000			Getto massimo 122,5	Main jet 122,5	Gicleur maxi 122,5	Hauptdüse 122,5	Surtidor máximo 122,5
10	1642092 000			Getto massimo 125	Main jet 125	Gicleur maxi 125	Hauptdüse 125	Surtidor máximo 125
10	1642260 000			Getto massimo 127,5	Main jet 127,5	Gicleur maxi 127,5	Hauptdüse 127,5	Surtidor máximo 127,5
10	1642093 000			Getto massimo 130	Main jet 130	Gicleur maxi 130	Hauptdüse 130	Surtidor máximo 130
11	1642361 000			Getto minimo 17,5	Starter jet 17,5	Gicleur starter 17,5	Starterdüse 17,5	Surtidor starter 17,5
11	1642435 000			Getto minimo 25	Starter jet 25	Gicleur starter 25	Starterdüse 25	Surtidor starter 25
11	1642342 000			Getto minimo 27,5	Starter jet 27,5	Gicleur starter 27,5	Starterdüse 27,5	Surtidor starter 27,5
11	1642436 000			Getto minimo 30	Starter jet 30	Gicleur starter 30	Starterdüse 30	Surtidor starter 30
12	2243115 000			Molla valvola	Valve spring	Ressort soupape	Ventilfeder	Muelle válvula
13	2243116 000			Molla spillo	Pin spring	Ressort pointeau	Feder Nadelventil	Muelle alfiler
14	2243117 000			Molla regolazione minimo	Idle adjuster spring	Ressort reg. min.	Feder luftregler min.	Muelle regulacion aire minimo
15	2587160 000			Polverizzatore	Nozzle	Pulvériseur	Verstäuber	Pulverizador
15	2587161 000	MY08		Polverizzatore	Nozzle	Pulvériseur	Verstäuber	Pulverizador
16	2723473 000			Raccordo sfciato olio	Oil breather joint	Raccord réinfiltrard huile	Entlüftungstutzen	Racor respiradero aceite
17	2764585 000			Rondella vite registro miscela minimo	Washer, idling mixture adj. Screw	Rondelle vis réglage mélange de ralenti	U.Scheibe Regulierschraube	Arandela tornillo regulación mezcla relenti
18	2894268 000			Spillo	Needle	Pointeau	Düsennadel	Aguja
19	2894272 000			Spillo ingresso benzina	Needle assy	Epingle compl.	Düsennadel	Aguja
20	3102184 000			Valvola a membrana	Diaphragm valve	Vanne à membrane	Membranventil	Valvula de membrana
21	3188603 000			Vite registro miscela minimo	Idling mixture adj. screw	Vis réglage mélange de ralenti	Regulierschraube	Tornillo regulación mezcla relenti
22	3611565 000			Valvola a spillo	Needle valve	Soupape à pointeau	Nadelventil	Válvula de aguja

Tav.14

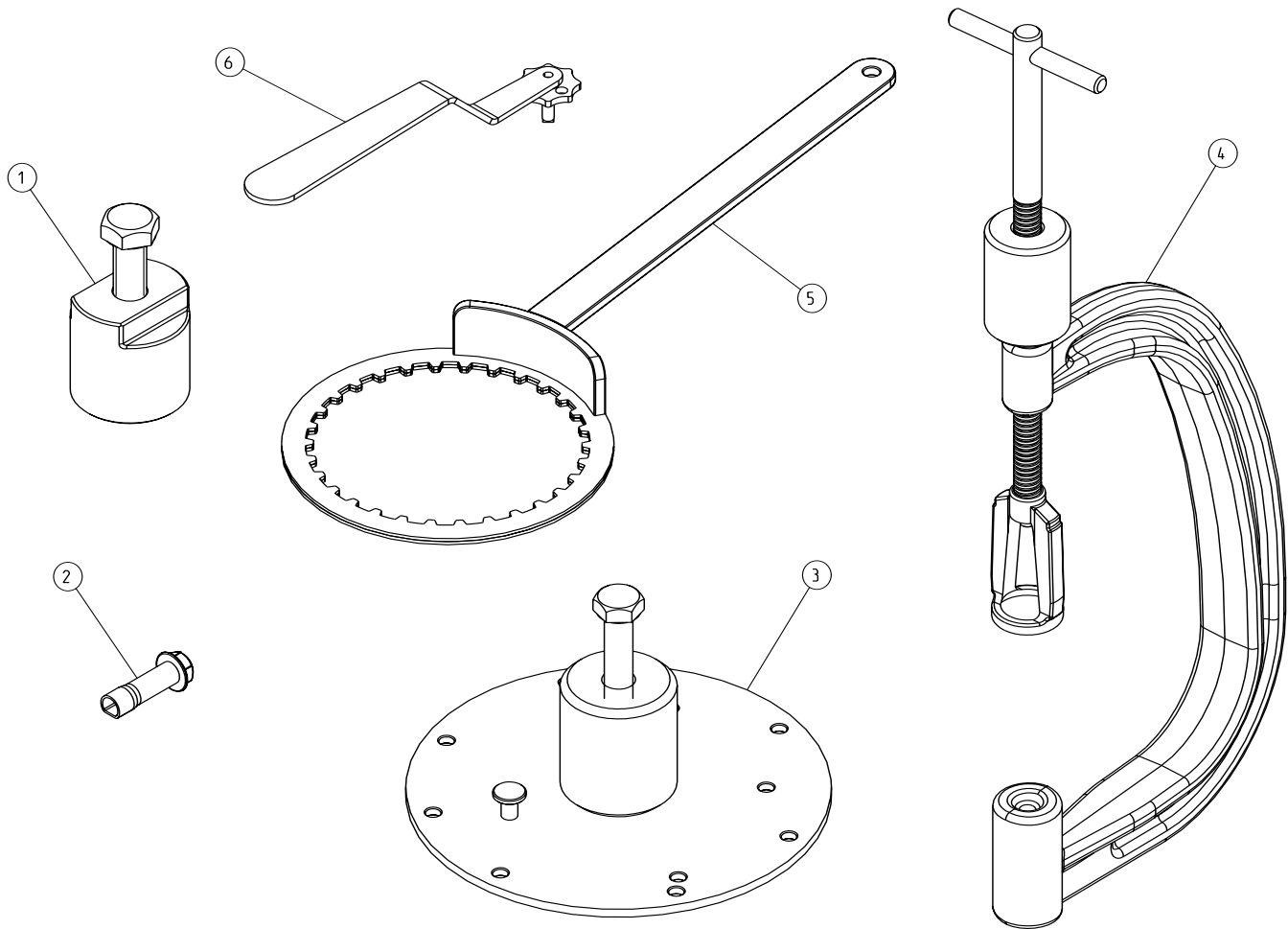

Pos Loc Pos Ps Pos	Numero Number Numéro Número Nummer	Q.tà Q.ty Q.té M.ge C.ad	Nota Note Note Nota Anm.	Descrizione	Description	Désignation	Beschreibung	Descripción
1	0100040 000	1		estrattore volano	Flywheel extractor	Extracteur pour volant	Auszieher für Schwungrad	Extractor volante
2	0100041 000	1		Chiave per albero pompa acqua	Key, water pump shaft	Clé pour arbre de pompe à eau	Schlüssel für wasserpumpenwelle	Llave para el eje de la bomba de agua
3	007140108 000	1		Disaccoppiatore carter	Crankcase splitter	Séparateur de carter	Entkoppler gehäuse	Desacoplador del cárter
4	0100043 000	1		Attrezzo mont.- smont. valvole	Valves ass. and rem. tool	Outil pour mont. dem. soup.	Werkzeug für Ventilmontage	Ut. montaje-desm. válvulas
5	0100044 000	1		Chiave bloccaggio mozzo frizione	Clutch hub retaining wrench	Cléf d'arrêt moyeau embrayage	Halterungsschlüssel der Kupplungsabe	Llave bloquear cubo fricción
6	0100045 000	1		Chiave di registro carburatore	Carburettor adjusting spanner	Clef de réglage carburateur	Schlüssel für Vergasereinstellung	Llave regulación carburador



Tav.31

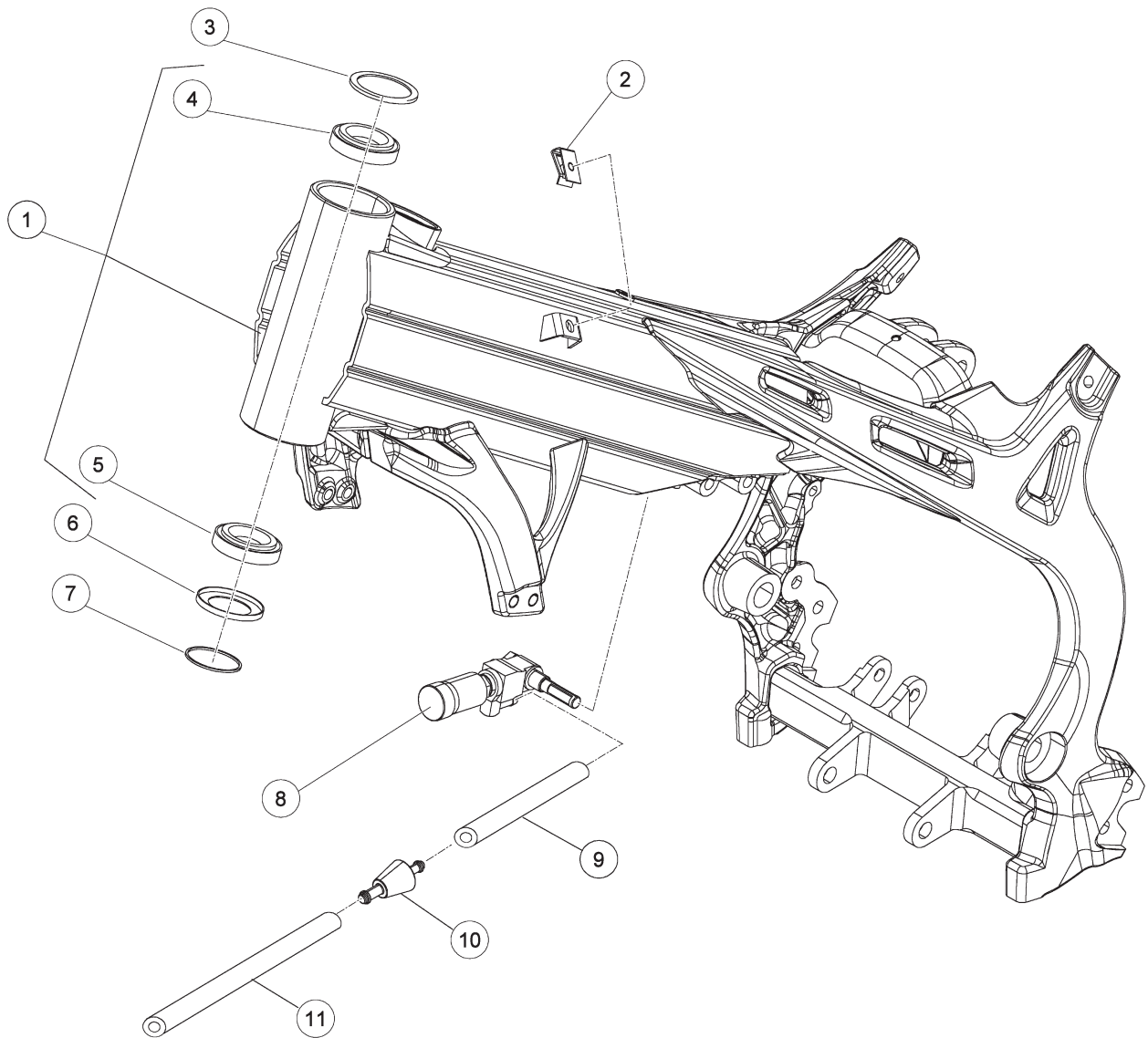

Pos Loc Pos Ps Pos	Numero Number Numéro Número Nummer	Q.tà Q.ty Q.té M.ge C.ad	Nota Note Note Nota Anm.	Descrizione	Description	Désignation	Beschreibung	Descripcìon
1	008310008 059	1		Telaio	Frame	Cadre	Rahmen	Chasis
2	2558060 000	1		Clip M5	Clip M5	Clip M5	Clip M5	Clip M5
3	2817750 100	1		Scodellino parapolvere	Dust cover	Cuvette pare-poussière	Staubdeckel	Cubeta gurdapolvo
4	1298300 000	1		Cuscinetto conico 20x42x15	Conical bearing 20x42x15	Roulement conique 20x42x15	Lager 20x42x15	Cojinete conico 20x42x15
5	1298300 000	1		Cuscinetto conico 20x42x15	Conical bearing 20x42x15	Roulement conique 20x42x15	Lager 20x42x15	Cojinete conico 20x42x15
6	1067390 000	1		Anello parapolvere	Dust cover	Disque pare-poussière	Staubdeckel	Disco gurdapolvo
7	1066860 000	1		Anello OR 34,6x2,62	Ring OR 34,6x2,62	Circlips OR 34,6x2,62	Ring OR 34,6x2,62	Anillo OR 34,6x2,62
8	008400010 000	1		Rubinetto benzina	Fuel cock.	Robinet melange	Kraftstoffhahn	Grifo mezcla
9	2915811 000	1		Tubo benzina 5x9	Gasoline tube 5x9	Tube essence 5x9	benzinschlauch 5x9	Tubo gasolina 5x9
10	1524651 000	1		Filtro benzina	Fuel filter	Filtre à essence	Benzinfilter	Filtro mezcla
11	2915817 000	1		Tubo benzina (0,50 m)	Petrol tube (0,50 m)	Tuyau d'essence (0,50 m)	Benzinschlauch (0,50 m)	Tubo gasolina (0,50 m)

Tav.32

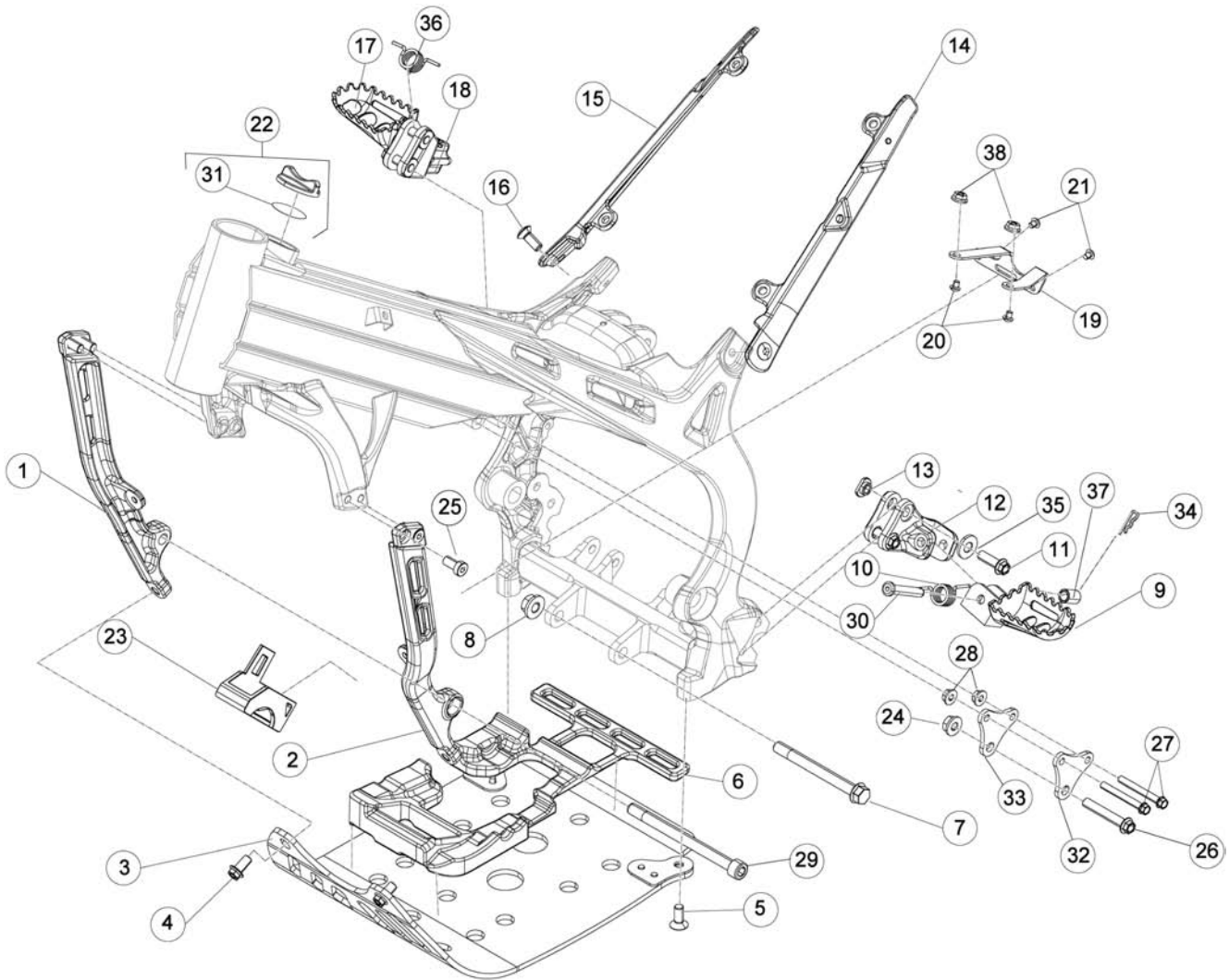

Tav.32

Pos Loc Pos Ps Pos	Numero Number Numéro Número Nummer	Q.tà Q.ty Q.té M.ge C.ad	Nota Note Note Nota Anm.	Descrizione	Description	Désignation	Beschreibung	Descrìcion
1	008320048 059	1		Braccetto anteriore dx.	Front right arm	Bras av. Droit	Vorder Rechter Schutzblecharm	Brazo del. der.
2	008320038 059	1		Braccetto anteriore sx.	Front left arm	Bras av. Gauche	Vorder Linker Schutzblecharm	Brazo del. izq.
3	008321408 000	1		Piastra supporto motore	Engine support plate	Plaque support moteur	Motorschutz	Placa soporte motor
4	1154521 000	2		Bullone M8x16	Bolt M8x16	Boulon M8x16	Bolzen M8x16	Tornillo M8x16
5	3163930 000	2		Vite TSPCE 8.20	Screw TSPCE 8.20	Vis TSPCE 8.20	Schraube TSPCE 8.20	Tornillo TSPCE 8.20
6	008320410 000	1		Gomma supporto motore	Engine support rubber	Caoutchouc support moteur	Gummi halter für Motor	Goma soporte motor
7	3165627 000	1		Vite speciale M10x100 passo 1,25	Special screw M10x100 passo 1,25	Vis spéciale M10x100 passo 1,25	Spezialschraube M10x100 passo 1,25	Tornillo especial M10x100 passo 1,25
8	1321050 000	1		Dado flangiato M10X1,25	Flanged nut M10X1,25	Ecrou bordé M10X1,25	Flanschmutter M10X1,25	Tuerca embridada M10X1,25
9	2532534 000	1		Pedana poggiapiedi Sx.	L.H. foot peg	Repose-pied gauche	Fussraste links	Estribera Izq.
10	2262020 000	1		Molla pedana sx	L.H. footrest spring	Ressort repose-pied gauche	Rasten/Feder li.	Muelle izqui. Estribera
11	3164070 000	4		Vite flangiata 8x30	Flanged screw 8x30	Vis à brides 8x30	Flanschschraube 8x30	Tornillo rebordeado 8x30
12	2899304 000	1		Supporto pedana Sx.	L.H. footrest bracket	Support repose pied gauche	Halter für die linke fußrasten	Soporte estribera izquierda
13	1884645 000	4		Inserto speciale M8	Special insert M8	Insert spéciale M8	Gewindeinsatz M8	Inserto especial M8
14	007320300 059	1		Staffa supporto filtro sx.	Filter support bracket, L.H.	Bride support filtre G.	Luftfilterbefestigung L.	Brida soporte filtro izq.
15	007320310 059	1		Staffa supporto filtro dx.	Filter support bracket, R.H.	Bride support filtre R.	Luftfilterbefestigung R.	Brida soporte filtro der.
16	007320320 000	2		Vite speciale M8x20	Special screw M8x20	Vis spéciale M8x20	Spezialschraube M8x20	Tornillo especial M8x20
17	2532524 000	1		Pedana poggiapiedi Dx.	R.H. foot peg	Repose-pied droit	Fussraste rechts	Estribera Der.
18	2899294 000	1		Supporto pedana Dx.	R.H. footrest bracket	Support repose pied droit	Halter für die rechte fußrasten	Soporte estribera derecha
19	008320100 005	1		Piastrina fiss. serbatoio olio freno post.	Retaining plate, rear brake oil tank	Plaque de fixation réservoir huile frein AR.	Befestigungsplatte Bremsflüssigkeitstank	Pastilla de fij. depósito aceite freno tras.
20	3130570 000	2		Vite TTLIC 6.20 testa 12	Screw TTLIC 6.20 testa 12	Vis TTLIC 6.20 testa 12	Schraube TTLIC 6.20 testa 12	Tornillo TTLIC 6.20 testa 12
21	1146501 000	2		Bullone M6x10	Bolt M6x10	Boulon M6x10	Bolzen M6x10	Tornillo M6x10
22	007320608 059	1		Tappo serbatoio	Filler cap	Bouchon de réservoir	Tankverschluss	Tapón depósito
23	008320200 000	1		Supporto centralina elettronica	ECU support	Support de la centrale électronique	Haltebügel für elektronisches Steuergerät	Soporte centralita electrónica
24	1317120 000	1		Dado M8 flangiato	Nut M8	Ecrou M8	Mutter M8	Tuerca M8
25	3163881 000	4		Vite a brugola TCCE 8.16 bassa	Allen screw TCCE 8.16	Vis à 6 pans TCCE 8.16	Sechskantschraube TCCE 8.16	Tornillo a llave allen TCCE 8.16
26	1155920 000	1		Bullone M8.60 rs ch10	Bolt M8.60 rs ch10	Boulon M8.60 rs ch10	Bolzen M8.60 rs ch10	Tornillo M8.60 rs ch10
27	1105535 000	2		Bullone 6.50 rs ch 8	Bolt 6.50 rs ch 8	Boulon 6.50 rs ch 8	Bolzen 6.50 rs ch 8	Tornillo 6.50 rs ch 8
28	1312550 000	2		Dado flangiato M6	Flanged nut M6	Ecrou bordé M6	Flanschmutter M6	Tuerca embridada M6
29	007320020 000	1		Vite TCCE M\10x127	Screw TCCE M\10x127	Vis TCCE M\10x127	Schraube TCCE M\10x127	Tornillo TCCE M\10x127
30	2554467 000	2		Perno pedana	Footrest pin	Pivot repose-pied	Rasten Pin	Eje estribera
31	1066680 000	1		Anello OR 28,25.33,49.2,62 viton	Ring OR 28,25.33,49.2,62 viton	Circlips OR 28,25.33,49.2,62 viton	Ring OR 28,25.33,49.2,62 viton	Anillo OR 28,25.33,49.2,62 viton
32	008320050 000	1		Piastra ancoraggio cilindro sx.	Plate, ret. Cylinder, L.H.	Plaque fixe. Cylindre G.	Halteplatte für Zylinder L.	Placa fij. cilindro izq.
33	008320050 000	1		Piastra ancoraggio cilindro sx.	Plate, ret. Cylinder, L.H.	Plaque fixe. Cylindre G.	Halteplatte für Zylinder L.	Placa fij. cilindro izq.
34	1281993 000	2		Copiglia 3x20	Split pin 3x20	Goupille 3x20	Splint 3x20	Grupilla 3x20
35	2749500 000	4		Rondella 8x18	Washer 8x18	Rondelle 8x18	U.Scheibe 8x18	Arandela 8x18
36	2262010 000	1		Molla pedana dx	R.H. footrest spring	Ressort repose-pied droit	Rasten/Feder re.	Muelle derch. Estribera
37	1346530 000	1		Distanziale 8x12x17	Spacer 8x12x17	Entretoise 8x12x17	Distanz 8x12x17	Distanciadador 8x12x17
38	1312550 000	2		Dado flangiato M6	Flanged nut M6	Ecrou bordé M6	Flanschmutter M6	Tuerca embridada M6

Tav.33

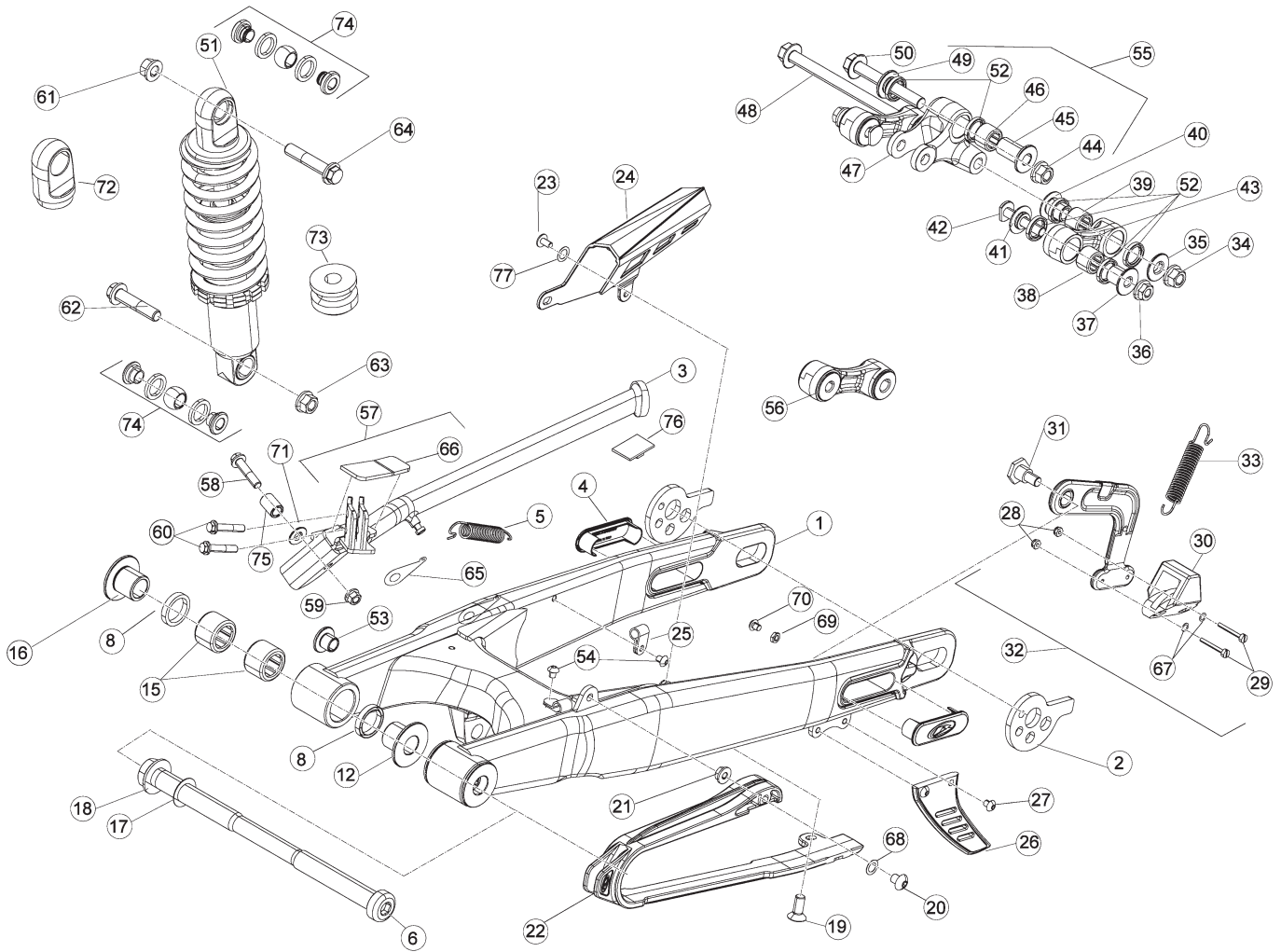

Beta
the play bike

Tav.33

Pos Loc Pos Ps Pos	Numero Number Numéro Número Nummer	Q.tà Q.ty Q.té M.ge C.ad	Nota Note Note Nota Anm.	Descrizione	Description	Désignation	Beschreibung	Descripcìon
1	008331000 004	1		Forcellone	Big fork	Fourche	Radschwinge	Horquilla
2	007330700 003	2		Tendicatena	Chain tightener	Tend. de ch.	Kettenspanner	Tens. de cad.
3	008330600 000	1		Cavalletto	Central stand	Béquille	Kippständer	Caballette
4	007330111 059	2		Tappo forcellone	Big fork plug	Bouchon fourche	Radschwinge verschluß	Tapón horquilla
5	2247024 000	1		Molla cavalletto	Central stand spring	Ressort béquille	Feder Kippständer	Muelle caballette
6	008330200 000	1		Perno forcellone	Swingarm pivot	Axe fourche AR.	Schwingbolzen	Eje basculante
8	007330100 000	1		Parapolvere interno 22x28x4	Inner dust cover 22x28x4	Pare-pouss. Interne 22x28x4	Innerer Staubdeckel 22x28x4	Guardapolvo interior 22x28x4
12	007331120 000	1		Boccola interna	Inside bush	Douille int.	Büchse innen	Casquillo interior
15	1122980 000	2		Boccola a rullini 22x28x16	Roller cage 22x28x16	Cage Aiguille 22x28x16	Rollenkäfig 22x28x16	Jaula rodillos 22x28x16
16	007331120 000	1		Boccola interna	Inside bush	Douille int.	Büchse innen	Casquillo interior
17	2767510 000	1		Rondella 16.25.1	Washer 16.25.1	Rondelle 16.25.1	U.Scheibe 16.25.1	Arandela 16.25.1
18	1329510 000	1		Dado speciale 16.1.25	Special nut 16.1.25	Ecrou spéciale 16.1.25	Spezialmutter 16.1.25	Tuerca especial 16.1.25
19	3130500 000	1		Vite M6x12 TSPCE	Screw M6x12 TSPCE	Vis M6x12 TSPCE	Schraube M6x12 TSPCE	Tornillo M6x12 TSPCE
20	3145110 000	1		Vite TBEI 6.35	Screw TBEI 6.35	Vis TBEI 6.35	Schraube TBEI 6.35	Tornillo TBEI 6.35
21	1313020 000	1		Dado autobloccante M6	Self locking nut M6	Ecrou de sécurité M6	Mutter, selbstsichernd M6	Tuerca de seguridad M6
22	008331180 000	1		Tassello guidacatena	Sliding block	Cheville guide de chaîne	Schwingschleifklotz	Protector cadena/basculante
23	3196829 000	1		Vite TCBEI M5x8 10.9	Screw TCBEI M5x8 10.9	Vis TCBEI M5x8 10.9	Schraube TCBEI M5x8 10.9	Tornillo TCBEI M5x8 10.9
24	008330501 059	1		Copricatena	Chain guard	Carter de chaîne	Kettenabdeckung	Cubre-cadena
25	1514300 000	2		Fascetta fissaggio tubo freno	Brake pipe fastening clamp	Collier fixation tube frein arriere	Befestigungsschelle Bremsschlauch	Brida fijacion freno post.
26	007330511 059	1		Protezione corona	Ring gear protection	Protection couronne dentee	Zahnkranzschutz	Protección corona
27	3129810 000	2		Vite 5x12	Screw 5x12	Vis 5x12	Schraube 5x12	Tornillo 5x12
28	1310910 000	2		Dado autobloccante M4	Self locking nut M4	Ecrou de sécurité M4	Mutter, selbstsichernd M4	Tuerca de seguridad M4
29	3126210 000	2		Vite TBCE m4x20	Screw TBCE m4x20	Vis TBCE m4x20	Schraube TBCE m4x20	Tornillo TBCE m4x20
30	008330540 000	1		Gomma pattino guida catena	Chain guide shoe rubber	Caoutchouc doigt guide-chaîne	Gummistück Gleitauflage	Goma patin guia cadena
31	007330560 000	1		Bullone speciale	Special bolt	Boulon spéciale	Spezialschraube	Tornillo especial
32	008331530 000	1		Pattino guida catena	Chain guide shoe	Doigt guide-chaîne	Gleitauflage	Patin guia cadena
33	2281112 000	1		Molla ritorno	Return spring	Ressort de retour	Rückschlagfeder	Muelle de retorno
34	1321050 000	1		Dado flangiato M10X1,25	Flanged nut M10X1,25	Ecrou bordé M10X1,25	Flanschmutter M10X1,25	Tuerca embreadada M10X1,25
35	007330320 000	1		Distanziale d.10 1.4,75	Spacer d.10 1.4,75	Entretoise d.10 1.4,75	Distanzstück d.10 1.4,75	Distanciadador d.10 1.4,75
36	1317040 000	1		Dado autobloccante flangiato M8x1,25	Self locking nut, flanged M8x1,25	Ecrou de sécurité bordé M8x1,25	Mutter, selbstsichernd M8x1,25	Tuerca de seguridad embreadada M8x1,25
37	007330350 000	1		Distanziale d.8 1.18,75	Spacer d.8 1.18,75	Entretoise d.8 1.18,75	Distanzstück d.8 1.18,75	Distanciadador d.8 1.18,75
38	007330380 000	1		Astuccio a rulli 15x21x14 RS	Roller cage 15x21x14 RS	Cage à roul. 15x21x14 RS	Rollenlagerkäfig 15x21x14 RS	Jaula rodillos 15x21x14 RS
39	007330380 000	1		Astuccio a rulli 15x21x14 RS	Roller cage 15x21x14 RS	Cage à roul. 15x21x14 RS	Rollenlagerkäfig 15x21x14 RS	Jaula rodillos 15x21x14 RS
40	007330340 000	1		Distanziale d.10 1.18,75	Spacer d.10 1.18,75	Entretoise d.10 1.18,75	Distanzstück d.10 1.18,75	Distanciadador d.10 1.18,75
41	007330330 000	1		Distanziale d.8 1.4,75	Spacer d.8 1.4,75	Entretoise d.8 1.4,75	Distanzstück d.8 1.4,75	Distanciadador d.8 1.4,75
42	007330370 000	1		Vite speciale	Special screw	Vis spéciale	Spezialschraube	Tornillo especial
43	007330310 000	1		Bielletta	Biellette	Connecting rod	Bolzensange	Bieleta
44	1321050 000	1		Dado flangiato M10X1,25	Flanged nut M10X1,25	Ecrou bordé M10X1,25	Flanschmutter M10X1,25	Tuerca embreadada M10X1,25
45	007330360 000	1		Distanziale lungo	Long spacer	Entretoise long	Lang Distanzstück	Distanciadador largo
46	007330390 000	2		Astuccio a rulli 15x21x12	Roller cage 15x21x12	Cage à roul. 15x21x12	Rollenlagerkäfig 15x21x12	Jaula rodillos 15x21x12
47	007330300 000	1		Bilanciere	Lever	Balancier	Kipphebel	Balancin
48	1162080 000	1		Bullone M10.125 1,25 (10.9)	Bolt M10.125 1,25 (10.9)	Boulon M10.125 1,25 (10.9)	Bolzen M10.125 1,25 (10.9)	Tornillo M10.125 1,25 (10.9)
49	007330460 000	1		Distanziale corto	Short spacer	Entretoise courte	Kurzer Abstandhalter	Distanciadador corto
50	1162070 000	1		Bullone M10.75 1,25 (10.9)	Bolt M10.75 1,25 (10.9)	Boulon M10.75 1,25 (10.9)	Bolzen M10.75 1,25 (10.9)	Tornillo M10.75 1,25 (10.9)
51	007332400 000	1		Ammortizzatore	Damper	Amortisseur	Stoßdämpfer	Amortiguador
52	007330450 000	10		Anello parapolvere GD 15x21x3	Dust cover GD 15x21x3	Disque pare-poussière GD 15x21x3	Staubdeckel GD 15x21x3	Disco gurdapolvo GD 15x21x3
53	007330090 000	2		Boccola	Bush	Moyeu	Büchse	Buje
54	3130080 000	2		Vite 5x10 TTLIC	Screw 5x10 TTLIC	Vis 5x10 TTLIC	Schraube 5x10 TTLIC	Tornillo 5x10 TTLIC
55	007330308 000	1		Bilanciere completo	Lever, assy.	Balancier complet	Kipphebel kpl.	Balancin compl.
56	007330318 000	2		Bielletta	Biellette	Connecting rod	Bolzensange	Bieleta
57	008330618 000	1		Supporto cavalletto	Central stand support	Support béquille	Halter für Ständer	Soporte caballette
58	3164030 000	1		Vite TBIB 8.30	Screw TBIB 8.30	Vis TBIB 8.30	Schraube TBIB 8.30	Tornillo TBIB 8.30
59	1317010 000	1		Dado autobloccante M8	Self locking nut M8	Ecrou de sécurité M8	Mutter, selbstsichernd M8	Tuerca de seguridad M8
60	1149070 000	2		Bullone 6x20 ch rs	Bolt 6x20 ch rs	Boulon 6x20 ch rs	Bolzen 6x20 ch rs	Tornillo 6x20 ch rs
61	1321050 000	1		Dado flangiato M10X1,25	Flanged nut M10X1,25	Ecrou bordé M10X1,25	Flanschmutter M10X1,25	Tuerca embreadada M10X1,25
62	1162060 000	1		Bullone fiss. Ammortizzatore M10.50 1,25 (10.9)	Damper sec. bolt M10.50 1,25 (10.9)	Boulon fix. amortisseur M10.50 1,25 (10.9)	Befestigungsbolzen M10.50 1,25 (10.9)	Tornillo fij amortiguador M10.50 1,25 (10.9)
63	1321050 000	1		Dado flangiato M10X1,25	Flanged nut M10X1,25	Ecrou bordé M10X1,25	Flanschmutter M10X1,25	Tuerca embreadada M10X1,25
64	1162050 000	1		Bullone fiss. ammortizzatore M10x45	Damper sec. bolt M10x45	Boulon fix. amortisseur M10x45	Befestigungsbolzen M10x45	Tornillo fij amortiguador M10x45
65	2557636 000	1		Piastrina aggancio molla	Bracket spring	Plaquette accroch. ressort	Plättchen federanlenkung	Placa eng. muelle
66	007330650 000	1		Gomma supporto cavalletto	Stand support rubber	Caoutchouc support béquille	Gummi halter für Ständer	Goma soporte caballette
67	2734650 000	2		Rondella	Washer	Rondelle	U.Scheibe	Arandela
68	2740500 000	1		Rondella 6x13	Washer 6x13	Rondelle 6x13	U.Scheibe 6x13	Arandela 6x13

Tav.33

Pos Loc Pos Ps Pos	Numero Number Numéro Número Nummer	Q.tà Q.ty Q.té M.ge C.ad	Nota Note Note Nota Anm.	Descrizione	Description	Désignation	Beschreibung	Descripcìon
69	1311000 000	1		Dado M5	Nut M5	Ecrou M5	Mutter M5	Tuerca M5
70	3129820 000	1		Vite M5x16 TBCE	Screw M5x16 TBCE	Vis M5x16 TBCE	Schraube M5x16 TBCE	Tornillo M5x16 TBCE
71	2749500 000	1		Rondella 8x18	Washer 8x18	Rondelle 8x18	U.Scheibe 8x18	Arandela 8x18
72	007330420 000	1		Mozzo completo	Hub, assy.	Moyeu compl.	Nabe, kompl.	Buje compl.
73	007330410 000	1		Tampone	Buffer	Silentbloc	Puffer	Silent-block
74	007330430 000	2		Gruppo snodo	Ball joint assy	Groupe joint a rotule	Kugelgelenkgruppe Kpl.	Grupo articulaciòn esfèrica
75	1346300 000	1		Distanziale cavalletto	Spacer stand	Entretoise bequille	Distanz REV	Distanciador caballete
76	1629510 000	1		Gommino battuta cavalletto	Stand stop rubber	Caoutchouc butée béquille	Anschlaggummi Ständer	Goma tope caballete
77	2736500 000	1		Rondella Ø5	Washer Ø5	Rondelle Ø5	U.Scheibe Ø5	Arandela Ø5

Tav.34

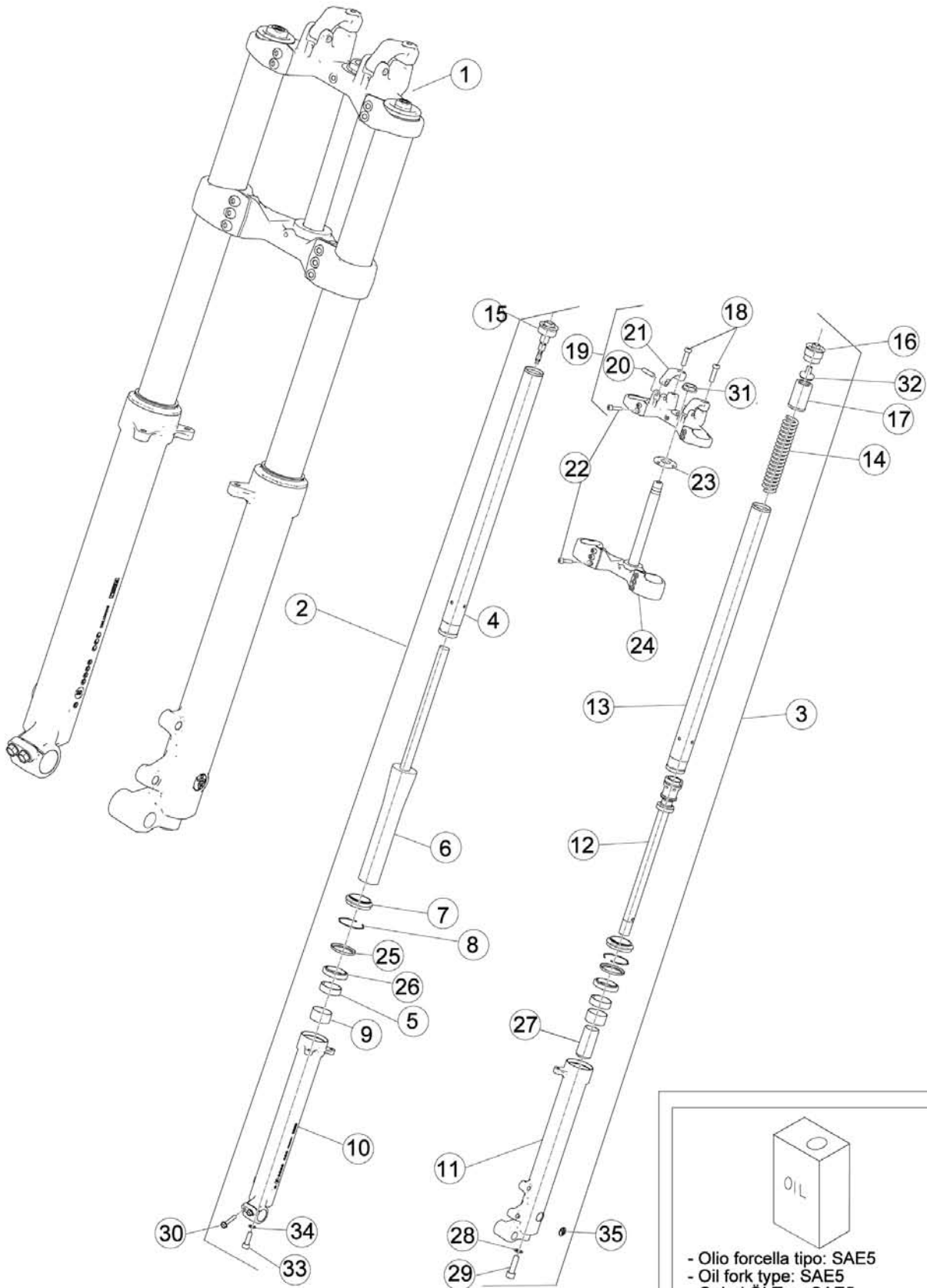

- Olio forcella tipo: SAE5
- Oil fork type: SAE5
- Gabel Öl-Typ: SAE5
- Huile de fourche type: SAE5
- Tipo de aceite horquilla: SAE5



Beta
the play bike

Tav.34

Pos Loc Pos Ps Pos	Numero Number Numéro Número Nummer	Q.tà Q.ty Q.té M.ge C.ad	Nota Note Note Nota Anm.	Descrizione	Description	Désignation	Beschreibung	Descripción
1	007345008 057	1		Forcella completa	Stirrup assy.	Fourchette compl.	Schaltgabel, Kompl.	Horquilla compl.
2	007342708 057	1		Gruppo portaruota dx completa	Complete right wheel-holder	Groupe tige porte roue droit	Vorderradhalterung gruppe re.	Grupo barra portarrueda derecho
3	007342308 057	1		Gruppo portaruota sx completa	Complete left wheel-holder	Groupe tige porte roue gauche	Vorderradhalterung gruppe li.	Grupo barra portarrueda izquierdo
4	007340908 000	1		Tube dx	RH tube	Tuyau D.	Rechte Gabelstandrohr	Tube derecho
5	1399940 000	2		Boccola	Bush	Moyeu	Büchse	Buje
6	007341000 000	1		Cartuccia forcella	Fork spares	Cartouche fourche	Gabeldaempfer	Cartucho horquilla
7	1041471 000	2		Parapolvere	Dust cover	Pare-pouss.	Staubdeckel	Guardapolvo
8	1041478 000	2		Anello fermo	Lock ring	Circlip	Sicherungsring	Anillo de seguridad
9	1399930 000	2		Boccola	Bush	Moyeu	Büchse	Buje
10	007342700 057	1		Gamba Dx.	R.H. leg	Tube D.	Beineinheit R.	Pata der.
11	007342300 057	1		Gamba Sx.	L.H. leg	Tube G.	Beineinheit L.	Pata izq.
12	007340620 000	1		Gruppo stelo	Rod assy	Groupe tige	Pumpenstuckgruppe	Grupo espiga
13	007340508 000	1		Tube sx	LH tube	Tuyau G.	Linke Gabelstandrohr	Tube izquierdo
14	008340600 000	1		Molla	Spring	Ressort	Feder	Muelle
15	007340808 000	1		Gruppo tappo dx.	Plug assy R.H.	Groupe bouchon D.	Verschlussgruppe Kpl R.	Grupo tapón der.
16	007340408 000	1		Gruppo tappo sx.	Plug assy L.H.	Groupe bouchon G.	Verschlussgruppe Kpl L.	Grupo tapón izq.
17	007340020 000	1		Distanziale	Spacer	Entretoise	Distanzstück	Distanciador
18	3163911 000	2		Vite TCCE M8.30	Screw TCCE M8.30	Vis TCCE M8.30	Schraube TCCE M8.30	Tornillo TCCE M8.30
19	007340208 000	1		Testa di sterzo	Steering head	Tête de direction	Gabelkopf	Tija superior
20	007340220 000	2		Perno	Pin	Pivot	Zapfen	Perno
21	007340210 000	2		Cavallotto	U bolt	Etrier	Brücke	Brida
22	3138010 000	10		Vite t.c.c.e. M6x25	Screw t.c.c.e. M6x25	Vis t.c.c.e. M6x25	Schraube t.c.c.e. M6x25	Tornillo t.c.c.e. M6x25
23	1620611 000	1		Ghiera registro forcella	Fork adjusting ring nut	Douille réglage fourche	Einstellung gabel	Casquillo regul. horquilla
24	007340108 000	1		Base di sterzo	Steering head base	Sacle de direction	Gabelkopf	Tija inferior
25	1041461 000	2		Anello tenuta	Oil seal	Bague d'étanchéité	Dichtring	Reten de ac.
26	2774790 000	2		Rondella	Washer	Rondelle	U.Scheibe	Arandela
27	007340030 000	1		Cono fine corsa sx.	Stopper cone L.H.	Cone fin de course G.	Endanschlagkonus L.	Cono final de carrera izq.
28	007340040 000	1		Rondella in rame	Copper washer	Rondelle en cuivre	Kupfer U.Scheibe	Arandela de cobre
29	3165305 000	1		Vite TCCE M10.35	Screw TCCE M10.35	Vis TCCE M10.35	Schraube TCCE M10.35	Tornillo TCCE M10.35
30	3196828 000	2		Vite flangiata M6.30	Flange bolt M6.30	Boulon de bride M6.30	Flanschschraube M6.30	Perno de reborde M6.30
31	007340050 000	1		Dado canotto	Head tube nut	Ecrou colonne	Lenkrohrmutter	Tuerca
32	007340010 000	1		Ghiera	Ring nut	Douille	Gewinding	Casquillo
33	3163910 000	1		Vite M8X30 TCCE	Screw M8X30 TCCE	Vis M8X30 TCCE	Schraube M8X30 TCCE	Tornillo M8X30 TCCE
34	007340060 000	1		Rondella	Washer	Rondelle	U.Scheibe	Arandela
35	024340550 000	2		Scudetto "BETA"	Shield "BETA"	Ecusson "BETA"	Schild "BETA"	Escudo "BETA"

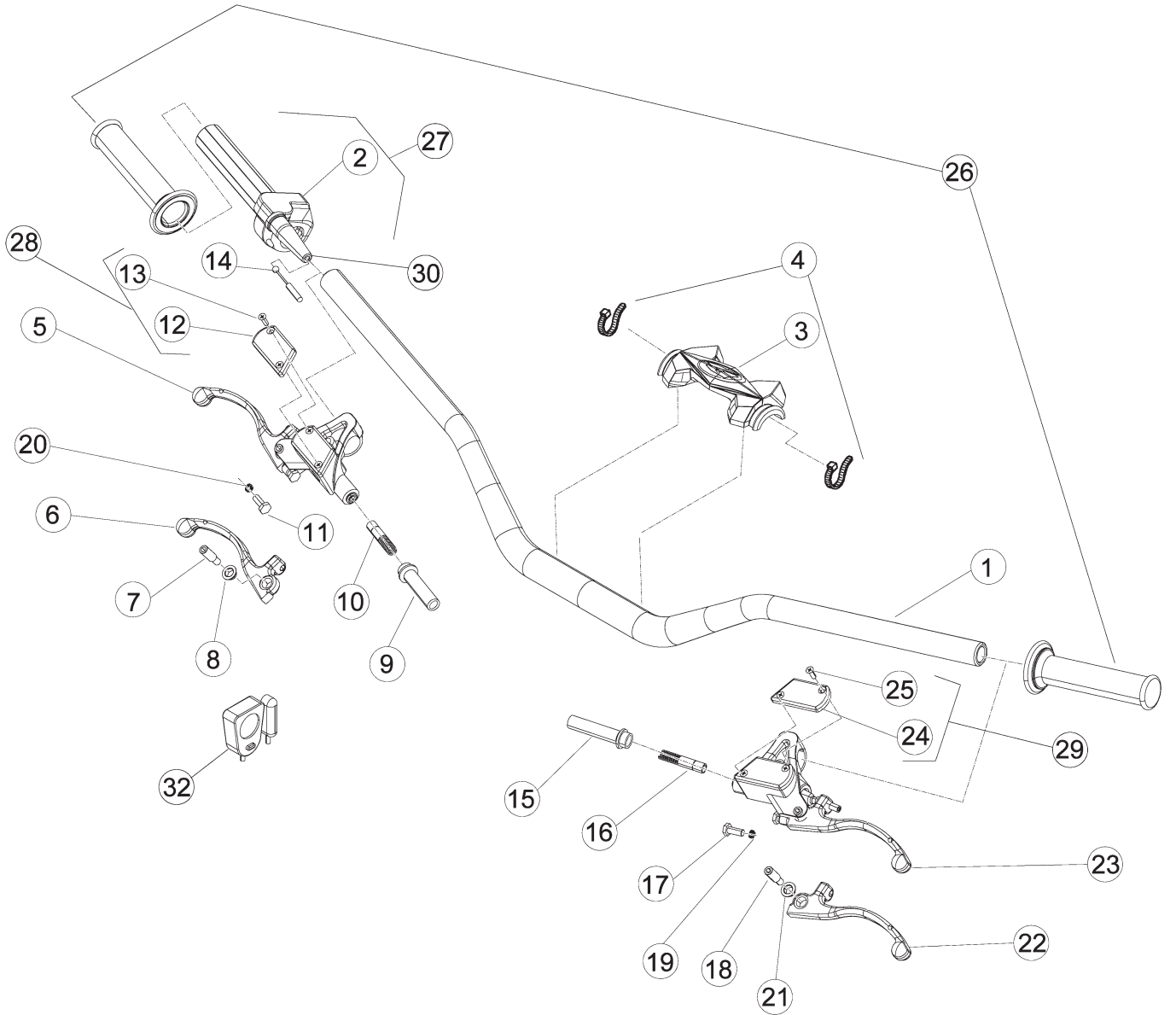

Tav.35

Pos Loc Pos Ps Pos	Numero Number Numéro Número Nummer	Q.tà Q.ty Q.té M.ge C.ad	Nota Note Note Nota Anm.	Descrizione	Description	Désignation	Beschreibung	Descripción
1	2220465 000	1		Manubrio	Handlebars	Guidon	Lenker	Manillar
2	1255960 000	1		Coperchio comando gas	Throttle control cover	Couvercle comm. gaz	Abdeckung Gasdrehgriff	Cubierta mando gas
3	007350650 000	1		Protezione in gomma	Rubber Boot	Protection En Caoutchouc	Gummibalg	Manguito Goma
4	1513020 000	2		Fascetta di nylon	Cable tie	Collier	Kabel-Schelle	Abrazadera
5	2102065 000	1		Leva comando freno	Brake lever	Levier du frein	Bremshebel	Palanca freno
6	2127103 000	1		Leva freno ant.	Fr. br. lever	Lev. fr. AV.	Vorderradbremshebel	Pal. fr. del.
7	3196818 000	1		Vite spec. X leva freno-frizione	Screw	Vis	Schraube	Tornillo
8	1126465 000	2		Boccola	Bush	Moyeu	Büchse	Buje
9	2909123 000	1		Tubo freno ant.	Front brake tube	Tuyau du frein AV.	Vordere Bremsleitung	Tubo freno delantero
10	2005083 800	1		Kit pistoncino pompa ant.	Piston kit front master cyl.	Kit piston. maître cyl. AV.	Kolbensatz vorderhauptbremszylinder	Kit pistón bomba del.
11	3188601 000	1		Vite registro freno anteriore	Adjusting screw	Vis réglage	Einstellschrauben	Tornillo reg.
12	1268107 000	1		Coperchio pompa olio	Oil pump cover	Couvercle pompe huile	Ölpumpendeckel	Tapa bomba aceite
13	3123410 052	2		Vite fiss. tappo serbatoio freno anteriore	Front brake tank cap fastening screw	Vis de fixation bouchon réservoir frein avant	Befestigungsschraube Vorderbremse Öltankstöpsel	Tornillo fijación tapón deposito freno delantero
14	008350140 000	1		Trasmissione acceleratore	Throttle transmission	Transmissioin accélérateur	Gaszug	Transmisión acelerador
15	2909103 000	1		Tubo frizione	Clutch tube	Canalisation embrague	Kupplungsrohr	Tubo embrague
16	2005083 800	1		Kit pistoncino pompa ant.	Piston kit front master cyl.	Kit piston. maître cyl. AV.	Kolbensatz vorderhauptbremszylinder	Kit pistón bomba del.
17	3188601 000	1		Vite registro freno anteriore	Adjusting screw	Vis réglage	Einstellschrauben	Tornillo reg.
18	3196818 000	1		Vite spec. X leva freno-frizione	Screw	Vis	Schraube	Tornillo
19	2238701 000	1		Molla regolazione frizione	Clutch spring	Ressort réglage embrayage	Stellfeder	Muelle regulac. embrague
20	2238701 000	1		Molla regolazione frizione	Clutch spring	Ressort réglage embrayage	Stellfeder	Muelle regulac. embrague
21	1126465 000	2		Boccola	Bush	Moyeu	Büchse	Buje
22	5127084 000	1		Leva com.friz.nuda	Clutch lever only	Levier complet embrayage nue	Kupplungshebel	Palanca embrague
23	2102431 000	1		Leva comando frizione	Clutch control lever	Levier de commande embrayage	Kupplungshebel	Palanca mando embrague
24	1268106 000	1		Coperchio serbatoio	Reservoir Lid	Couvercle De Réservoir	Behälterdeckel	Calderín Lid
25	3123410 052	2		Vite fiss. tappo serbatoio freno anteriore	Front brake tank cap fastening screw	Vis de fixation bouchon réservoir frein avant	Befestigungsschraube Vorderbremse Öltankstöpsel	Tornillo fijación tapón deposito freno delantero
26	2218531 000	1		Coppia manopole	Grips (couple)	Poignées (couple)	Handgriffpaar	Manecilla (juego)
27	1255093 000	1		Comando gas	Throttle control	Comm. gaz	Gasdrehgriff	Mando gas
28	2005075 000	1		Tappo completo	Complete cap	Bouchon complet	Verschluß komplett	Tapón completo
29	2005074 000	1		Tappo completo	Complete cap	Bouchon complet	Verschluß komplett	Tapón completo
30	1634080 000	1		Gommino	Rubber buffer	Caoutchouc	Gummi	Goma
32	007350600 000	1		Contakm digitale	Speedometer	Compteur	Tachometer	Cuenta km. tr.

Tav.36

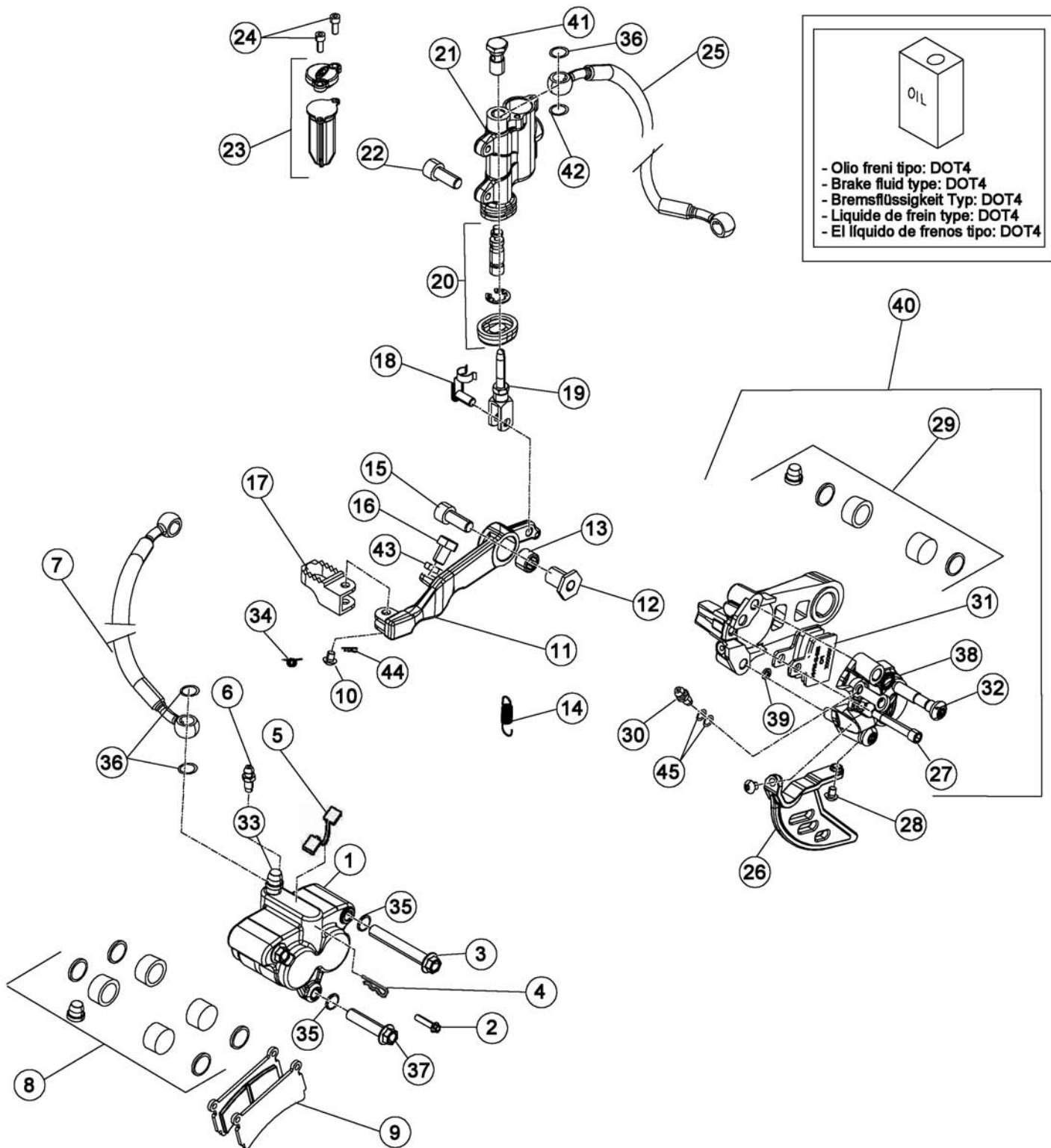

Tav.36

Pos Loc Pos Ps Pos	Numero Number Numéro Número Nummer	Q.tà Q.ty Q.té M.ge C.ad	Nota Note Note Nota Anm.	Descrizione	Description	Désignation	Beschreibung	Descrìcion
1	2503059 000	1		Pinza freno ant.	Front disk brake caliper	Etrier de frein AV.	Vorderrad Bremszange	Pinza del freno del.
2	1170521 000	1		Bullone fiss. Pastiglie	Brake pads fastening bolt	Boulon de fixation jeu past. fr.	Befestigungsbolzen Bremszange	Tornillo fijación Juego past. Frenos
3	1155900 000	1		Bullone M8x55	Bolt M8x55	Boulon M8x55	Bolzen M8x55	Tornillo M8x55
4	2232206 000	1		Molla ferma pastiglie pinza	Brake pads spring for pliers	Ressort arret plaquettes	Haltefeder	Muelle pastillas pinza
5	2598915 000	1		Protezione pastiglie freno	Brake pads cover	Protection jeu past. fr.	Bremzangenschutz	Protección Juego past. Frenos
6	3196801 000	1		Vite spurgo pinza	Special screw	Vis pour pince	Spezial schraube	Tornillo aliento pinza
7	2909123 000	1		Tubo freno ant.	Front brake tube	Tuyau du frein AV.	Vordere Bremsleitung	Tubo freno delantero
8	2002714 000	1		Kit pistoncini e guarniz. Pinza	Piston e oil seal for pliers	Jeu petit pistons et joint pince	Reparatursatz Bremszange	Juego piston y guarnicion pinza
9	2525352 000	1		Pastiglie per pinza	Brake pads	Plaquettes pince	Bremsbeläge hinten	Pastillas pinza
10	2554450 000	1		Perno pedale freno post.	Pivot for rear brake pedal	Pivot pour pédale frein AR.	Pedalzapfen	Perno pedal freno tras.
11	007361400 000	1		Pedale freno	Brake pedal	Pédale frein	Fussbremspedal	Pedal freno
12	1126611 000	1		Boccola	Bush	Moyeu	Büchse	Buje
13	1122220 000	1		Boccola a rullini 12x18x16 2rs	Roller cage 12x18x16 2rs	Cage Aiguille 12x18x16 2rs	Rollenkäfig 12x18x16 2rs	Jaula rodillos 12x18x16 2rs
14	007360440 000	1		Molla pedale freno	Brake pedal spring	Ressort Pédale Frein	Feder Fussbremspedal	Muelle pedal de freno
15	3163890 000	1		Vite a brugola 8x20 TCCE	Allen screw 8x20 TCCE	Vis à 6 pans 8x20 TCCE	Sechskantschraube 8x20 TCCE	Tornillo a llave allen 8x20 TCCE
16	1146250 000	1		Bullone 5x12	Bolt 5x12	Boulon 5x12	Bolzen 5x12	Tornillo 5x12
17	2290052 000	1		Mozzetto con pedana	Footrest hub	Moyeu a/ repose pieds	Rasten Nabe Fußbremshebel	Puntera pedal freno
18	2893130 000	1		Staffa	Bracket	Support	Halterung	Soporte
19	1084040 000	1		Asta com.pompa freno post	Rear brake rod	Tige de commande pompe frein	Betaätigungsstange Bremse hi.	Varilla bomba freno post.
20	007361510 000	1		Pistoncino completo pompa	Piston assy, pump	Piston compl. pompe	Kolben klpt. Pumpe	Piston completo bomba
21	007361508 000	1		Pompa freno post.	Rear brake master cyl.	Mâitre cylindre fr. AR.	Hauptbremszylinder	Bomba fr. tras. Hinterradbremse
22	3131050 000	2		Vite t.c.c.e.M6x15	Screw t.c.c.e.M6x15	Vis t.c.c.e.M6x15	Schraube t.c.c.e.M6x15	Tornillo t.c.c.e.M6x15
23	2915810 000	1		Tubo olio	Oil tube	Tuyau huile	Schlauch	Tubo aceite
24	007361520 000	1		Kit tappo	Plug kit	Jeu bouchon	Verschluss Gruppe	Kit tapón
25	007361530 000	1		Vite M4	Screw M4	Vis M4	Schraube M4	Tornillo M4
26	007360751 059	1		Copridisco	Disc cover	Couvre-disque	Scheibenabdeckung	Cubredisco
27	1170520 000	1		Bullone fiss. Pastiglie	Brake pads fastening bolt	Boulon de fixation jeu past. fr.	Befestigungsbolzen Bremszange	Tornillo fijación Juego past. Frenos
28	3126200 000	2		Vite 4x14 TCIC	Screw 4x14 TCIC	Vis 4x14 TCIC	Schraube 4x14 TCIC	Tornillo 4x14 TCIC
29	007360790 000	1		Kit pistoncini e guarniz. Pinza	Piston e oil seal for pliers	Jeu petit pistons et joint pince	Reparatursatz Bremszange	Juego piston y guarnicion pinza
30	007360780 000	1		Bullone forato + spurgo	Pierced bolt + Bleed	Boulon avec trou + Vidange	Bolzen + Ablaß	Tornillo + Purga
31	007360718 000	1		Pastiglie freno post.	Rear brake pads	Pastill. de freins AR.	Hinterbremsbelag	Pastillas frenos tras.
32	007360770 000	2		Bullone fiss. pinza	Plier fastening bolt	Boulon de fixation pince	Befestigungsbolzen Bremszange	Tornillo fijación pinza
33	1165040 000	1		Bullone forato 10x1 x tubo freno	Special bolt	Boulon 10x1 x tube frein	Hohlschraube F.Bremse	Tornillo esp. talad.10.1
34	2262090 000	1		Molla ritorno pedale freno	Return brake pedal spring	Ressort de retour frein	Bremspedal Feder	Muelle retorno palanca freno
35	2749500 000	2		Rondella 8x18	Washer 8x18	Rondelle 8x18	U.Scheibe 8x18	Arandela 8x18
36	1650510 000	3		Guarnizione 10x15x1 in rame	Gasket 10x15x1 copper	Joint 10x15x1 cuivre	Dichtung 10x15x1 Kupfer	Junta 10.15.1 (cobre)
37	1155470 000	1		Bullone M8x35	Bolt M8x35	Boulon M8x35	Bolzen M8x35	Tornillo M8x35
38	2756055 000	1		Rondella	Washer	Rondelle	U.Scheibe	Arandela
39	007360760 000	1		Rondella	Washer	Rondelle	U.Scheibe	Arandela
40	008361708 000	1		Pinza freno posteriore	Rear disk brake caliper	Etrier de frein AR.	Bremszange	Pinza del freno tras.
41	1165040 000	1		Bullone forato 10x1 x tubo freno	Special bolt	Boulon 10x1 x tube frein	Hohlschraube F.Bremse	Tornillo esp. talad.10.1
42	1650511 000	1		Guarnizione 10x15x2 rame	Packing 10x15x2 rame	Joint 10x15x2 rame	Dichtung 10x15x2 rame	Junta 10x15x2 rame
43	1310990 000	1		Dado 5.3,5 ch8	Nut 5.3,5 ch8	Ecrou 5.3,5 ch8	Mutter 5.3,5 ch8	Tuerca 5.3,5 ch8
44	1281995 000	1		Copiglia 2x15	Split pin 2x15	Goupille 2x15	Splint 2x15	Grupilla 2x15
45	007360810 000	2		Rondella	Washer	Rondelle	U.Scheibe	Arandela

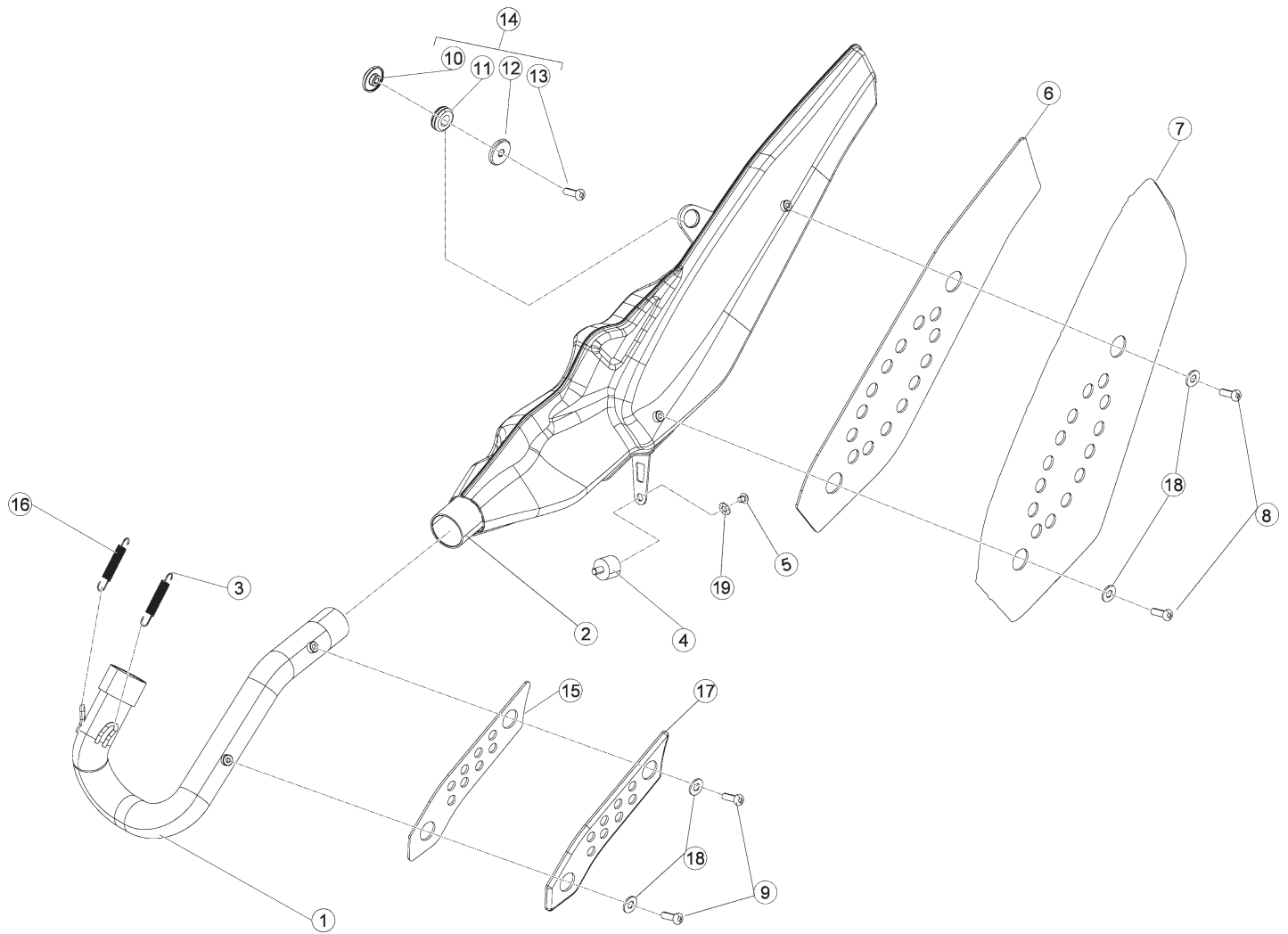

Pos Loc Pos Ps Pos	Numero Number Numé ro Número Numer	Q.tà Q.ty Q.té M.ge C.ad	Nota Note Note Nota Anm.	Descrizione	Description	Dé signation	Beschreibung	Descripció n
1	008372018 000	1		Collettore	Manifold	Collecteur	Anschlußstück	Colector
2	008372108 000	1		Marmitta completa	Muffler, assy.	Pot d' echappement complet	Auspufftopf kpl.	Silenciador completo
3	2248823 000	1		Molla tubo di scarico	Exhaust pipe spring	R ressort tuyau echapp.	Krummerfeder	Muelle tubo de escape
4	007370900 000	1		Silent block marmitta	Silencer puffer	Silent block silencieux	Silent block Auspuff	Silent block escape
5	3130490 051	1		Vite a brugola 6x8	Allen screw 6x8	Vis à 6 pans 6x8	Sechskantschraube 6x8	Tornillo a llave allen 6x8
6	008370510 000	1		Feltro isolante protez. Marmitta	Soundproofing felt silencer shield	Feutre isolant prot. silenc.	Daemmaterial seitenteil Auspuffverkleidung	Fieltro aislante protecció n escape
7	008370500 000	1		Protezione marmitta	Silencer shield	Protection silencieux	Auspuffverkleidung	Protecció n escape
8	3196829 000	2		Vite TCBEI M5x8 10.9	Screw TCBEI M5x8 10.9	Vis TCBEI M5x8 10.9	Schraube TCBEI M5x8 10.9	Tornillo TCBEI M5x8 10.9
9	3196829 000	2		Vite TCBEI M5x8 10.9	Screw TCBEI M5x8 10.9	Vis TCBEI M5x8 10.9	Schraube TCBEI M5x8 10.9	Tornillo TCBEI M5x8 10.9
10	007370360 000	1		Scodellino	Stop washer	Rondelle d' ar	Federaufnahme	Platillo
11	007370350 000	1		Silent block	Silentbloc	Silent block	Puffer	Silent block
12	007370370 000	1		Scodellino filettato	Threaded cup	Cuvette fileté	Gewindeteller	Cubeta filete
13	3130790 000	1		Vite TBCE 6.25*	Screw TBCE 6.25*	Vis TBCE 6.25*	Schraube TBCE 6.25*	Tornillo TBCE 6.25*
14	007370348 000	1		Silent block	Silentbloc	Silent block	Puffer	Silent block
15	008372030 000	1		Feltro isolante collettore	Soundproofing felt exhaust manifold	Feutre isolant collecteur d' échapp.	Daemmaterial seitenteil Abgaskrü mmer	Fieltro aislante colector de escape
16	2248823 000	1		Molla tubo di scarico	Exhaust pipe spring	R ressort tuyau echapp.	Krummerfeder	Muelle tubo de escape
17	008372020 000	1		Protezione tubo scarico	Silencer shield	Protection tube d' echappement	Abedeckung Auspuff	Proteccion tubo escarico
18	1647492 000	4		Guarnizione isolante 5.10.1,5	Gasket 5.10.1,5	Joint 5.10.1,5	Dichtung 5.10.1,5	Junta 5.10.1,5
19	2737500 000	1		Rondella a ventaglio D.6	Lock washer D.6	Rondelle à dents D.6	Fü cherscheibe D.6	Arandela a banicada D.6



Tav.38

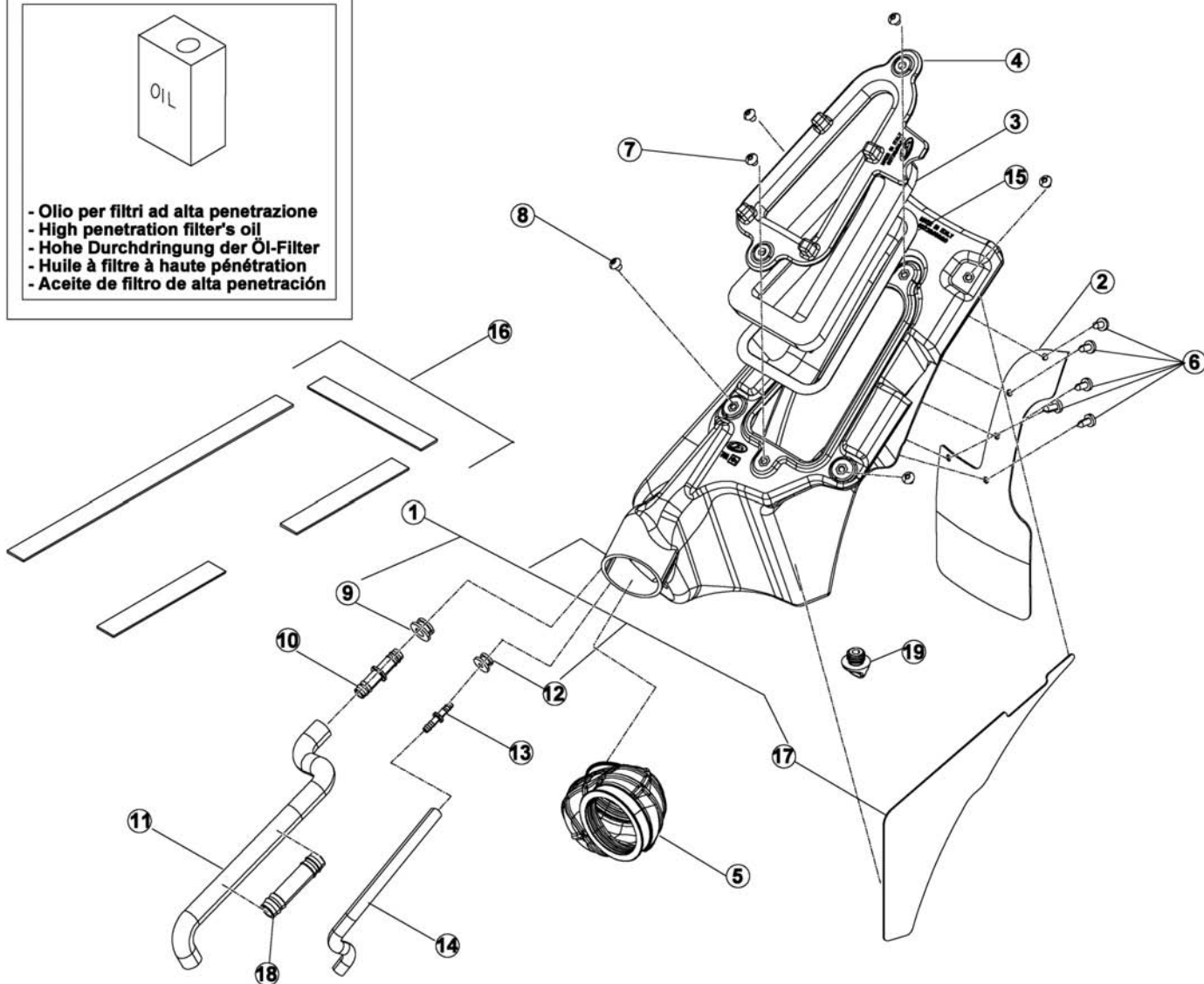

Pos	Numero	Q.tà	Nota	Descrizione	Description	Désignation	Beschreibung	Descripcìon
Loc	Number	Q.ty	Note					
Pos	Numéro	Q.té	Note					
Ps	Número	M.ge	Nota					
Pos	Nummer	C.ad	Anm.					
1	008380008 000	1		Scatola filtro completa	Air cleaner box	Boîtier filtre à air	Luftfiltergehäuse	Caja filtro de aire
2	007380010 000	1		Protezione ammortizzatore	Guard	Protection	Schutz	Protección
3	007380040 000	1		Elemento filtrante	Filtering element	Élément filtrant	Luftfilterelement	Filtro
4	008380141 059	1		Coperchio scatola filtro	Filter case cover	Couvercle boîte filtre	Filtergehäusedeckel	Tapa caja filtro
5	008380060 000	1		Manicotto scatola filtro	Filter box sleeve	Manchon boîte du filtre	Filtergehäusemuffe	Manguito caja filtro
6	3123580 000	5		Vite 4,8x13	Screw 4,8x13	Vis 4,8x13	Schraube 4,8x13	Tornillo 4,8x13
7	3129810 000	2		Vite 5x12	Screw 5x12	Vis 5x12	Schraube 5x12	Tornillo 5x12
8	3129826 000	4		Vite 5x10 TBCEI	Screw 5x10 TBCEI	Vis 5x10 TBCEI	Schraube 5x10 TBCEI	Tornillo 5x10 TBCEI
9	1633785 000	1		Gommino	Rubber buffer	Caoutchouc	Gummi	Goma
10	008380200 000	1		Raccordo BLOW-BY	Union BLOW-BY	Raccord BLOW-BY	Anschluss BLOW-BY	Empalme BLOW-BY
11	008380110 000	1		Tubo ventilazione	Ventilation hose	Tuyau ventilation	Lüftungsrohr	Tubo de ventilación
12	1634902 000	1		Gommino strumento digitale	Rubber	Caoutchouc instrument digital	Gummidichtung digitales cockpit	Goma instrumento digital
13	2711320 000	1		Raccordo per cuffia	Cup fitting	Raccord pour recueil huile	Plattenanschlußstück	Racor para envoltura
14	2915811 000	1		Tubo benzina 5x9	Gasoline tube 5x9	Tube essence 5x9	benzinschlauch 5x9	Tubo gasolina 5x9
15	008380058 000	1		Rompifiamma	Flame arrester	Pareflamme	Schutz vor Flammrückschlag	Guardallamas
16	007380200 000	1		Guarnizione filtro	Packing	Joint du filtre	Filterdichtung	Junta
17	008380070 000	1		Feltro isolante scatola filtro	Soundproofing felt filter box	Feutre isolant boîtier du filtre	Daemmaterial seitenteil	Fieltro aislante caja del filtro
18	2731780 000	1		Riduzione fumi	Reducteur de la fumée	Reduction of fumes	Rauchreduzierung	Reductor del humo
19	2910293 000	1		Tappo	Plug	Bouchon	Verschluss	Tapón

Tav.39

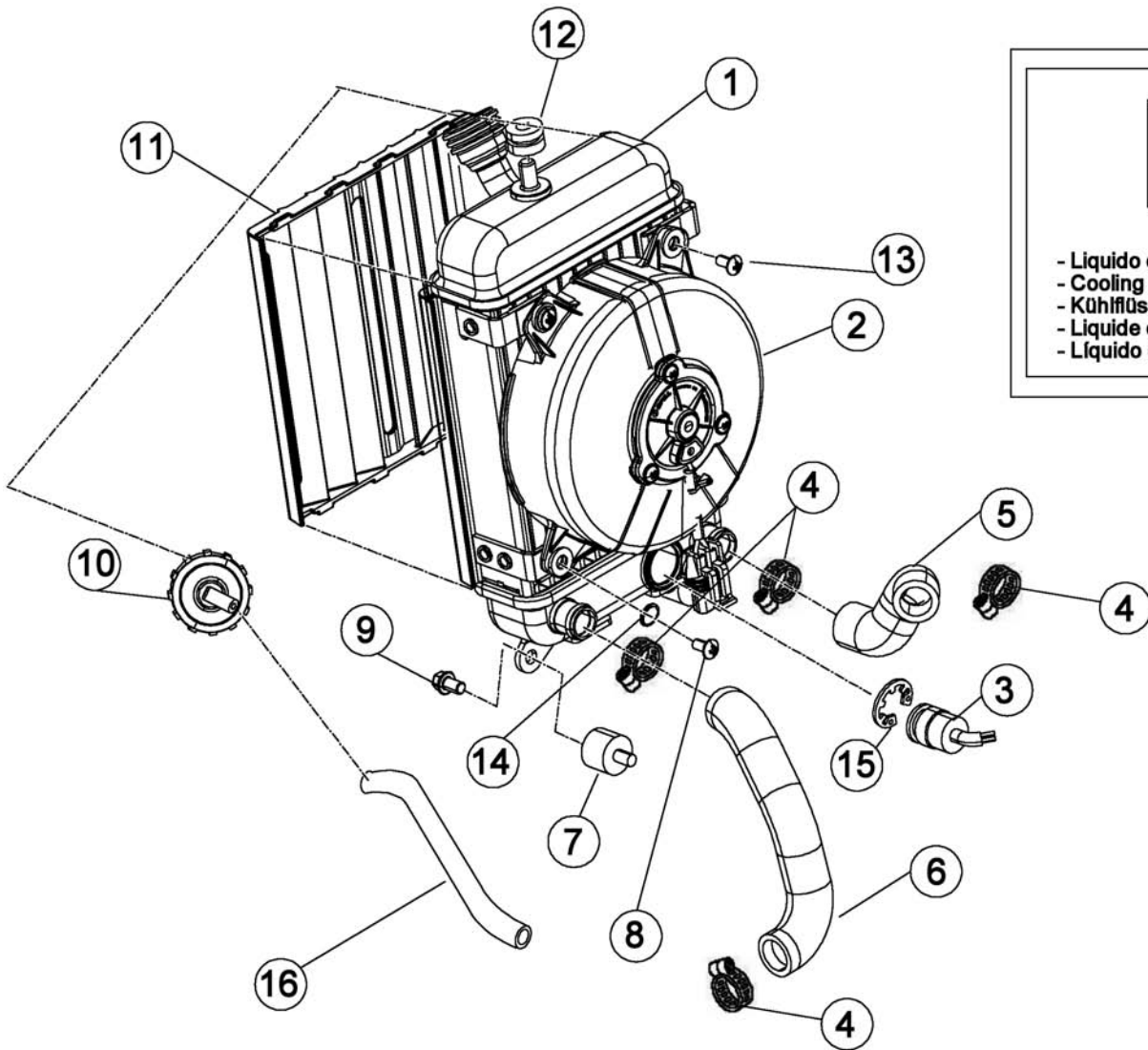

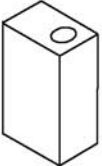

 - Liquido di raffreddamento
 - Cooling liquid
 - Kühflüssigkeit
 - Liquide de refroidissement
 - Líquido de refrigeración

Pos Loc Pos Ps Pos	Numero Number Numéro Número Nummer	Q.tà Q.ty Q.té M.ge C.ad	Nota Note Note Nota Anm.	Descrizione	Description	Désignation	Beschreibung	Descripción
1	007392000 000	1		Radiatore	Cooler	Radiateur	Kühler	Radiador
2	1401030 000	1		Elettroventola	Electric fan	Electro-ventilateur	Elektrolüfter	Electroventilador
3	008391100 000	1		Termointerruttore	Thermal switch	Thermo-régulateur	Umschalter	Interruptor térmico
4	1515230 000	4		Fascetta 15x25	Clamp 15x25	Collier 15x25	Schelle 15x25	Abrazadera 15x25
5	2915737 000	1		Tubo radiatore dx.	R.H. radiator hose	Tuyau radiateur D.	Kühlerschlauch R.	Tubo radiador der.
6	2915738 000	1		Tubo radiatore sx.	L.H. radiator hose	Tuyau radiateur G.	Kühlerschlauch L.	Tubo radiador izq.
7	2891942 000	2		Silent block	Silentbloc	Silent block	Puffer	Silent block
8	3130570 000	1		Vite TTLIC 6.20 testa 12	Screw TTLIC 6.20 testa 12	Vis TTLIC 6.20 testa 12	Schraube TTLIC 6.20 testa 12	Tornillo TTLIC 6.20 testa 12
9	1146501 000	2		Bullone M6x10	Bolt M6x10	Boulon M6x10	Bolzen M6x10	Tornillo M6x10
10	2901821 000	1		Tappo radiatore REV3	Radiator plug REV3	Bouchon radiateur REV3	Kühlerdeckel REV3	Tapa de radiador REV3
11	1645543 159	1		Griglia radiatore	Radiator grille	Calandre	Kühlergrill	Reja del radiador
12	1634905 000	1		Gommino kontakm	Odometer gasket	Joint caoutchouc compteurKM	Gummidichtung für Kilometerzähler	Junta de goma cuentaKM
13	3130520 000	3		Vite 6x16 TTLIC	Screw 6x16 TTLIC	Vis 6x16 TTLIC	Schraube 6x16 TTLIC	Tornillo 6x16 TTLIC
14	2743000 000	4		Rondella in gomma 6.20.3	Rubber washer 6.20.3	Rondelle en caoutchouc 6.20.3	Gummiunterlegscheibe 6.20.3	Arandela de goma 6.20.3
15	2825380 000	1		Seeger 20i	Circlip 20i	Circlip 20i	Seeger 20i	Seeger 20i
16	2915814 000	1		Tubo gomma (0,7m)	Rubber hose (0,7m)	Tuyau en caoutchouc (0,7m)	Gummischlauch (0,7m)	Tubo en goma (0,7m)

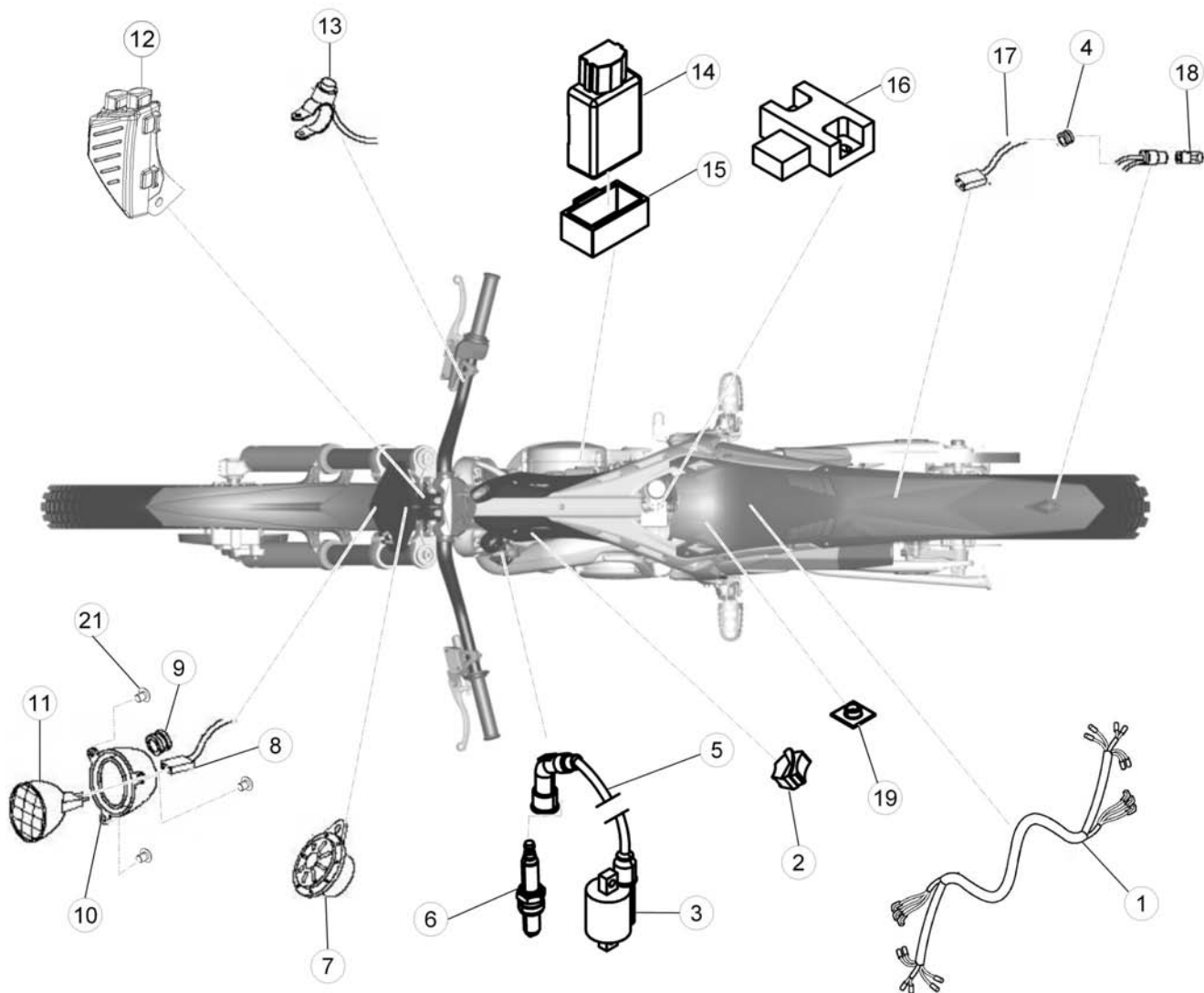

Beta
the play bike

Tav.40



Pos	Numero	Q.tà	Nota	Descrizione	Description	Désignation	Beschreibung	Descripció
Loc	Number	Q.ty	Note					
Pos	Número	Q.té	Note					
Ps	Número	M.ge	Nota					
Pos	Nummer	C.ad	Anm.					
1	008401100 000	1		Impianto centrale	Electric equipment	Installation centrale	Zentraler Kabelbaum	Instalacion central
2	007400300 000	1		Dispositivo switch mappatura	Mapping switch device	Dispositif switch schéma	Speicheraufteilung Switch	Dispositivo switch calibración
3	1120681 800	1		Bobina	Coil	Bobine	Spule	Bobina
4	1634903 000	2		Gommino fissaggio cavi	Rubber pad	Pièce caoutchouc	Gummistück	Goma
5	2713555 000	1		Raccordo candela	Plug fitting	Raccord bougie	Kerzenanschluß	Racor bujía
6	1225195 000	1		Candela	Spark plug	Bougie	Zundkerze	Bujía
7	007400500 000	1		Avvisatore acustico	Warning horn	Avertisseur sonore	Hupe	Claxon
8	1801516 000	1		Impianto elettrico anteriore	Front harness	Installation électrique AV.	Elektrische anlage vorne	Sistema eléctrico del.
9	1634906 000	1		Gommino passacavo	Fairlead rubber ring	Joint en caoutchouc passe-câble	Kabeldurchgangsgummi	Junta de goma pasa-cable
10	1203161 000	1		Corpo proiettore	Reflector housing	Corps du projecteur	Scheinwerfergehäuse	Cuerpo faro
11	2116751 000	1		Lampadina proiettore	Headlamp bulb	Ampoule projecteur	Scheinwerferlampe	Lámpara faro
12	007351508 000	1		Dip luci	Switch	Commodo feux	Lichtschalter	Mando luces
13	007350550 000	1		Pulsante avvisatore acust.	Horn push button	Bouton avertisseur sonore	Horndruckknopf	Pulsador de bocina
14	008100110 000	1	250cc	Centralina digitale	CDI unit	Bobine digital (C.D.I.)	Steuergerät	Centralita digital
14	008101110 000	1	300 cc	Centralina digitale	CDI unit	Bobine digital (C.D.I.)	Steuergerät	Centralita digital
15	1623325 000	1		Supporto in gomma centralina	Rubber bracket, CDI UNIT	Support en caoutchouc CDI	Gummihalter f. Steuergehäuse	Soporte en goma
16	007400400 000	1		Regolatore	Regulator	Régulateur	Regler	Regulador
17	007401240 000	1		Impianto posteriore	Rear harness	Circuit post.	Anlage hinten	Instalación tras.
18	2115655 000	1		Lampadina fanalino posteriore	Tail lamp bulb	Ampoule feu AR.	Rücklichtlampe	Lámpara piloto
19	2524430 000	2		Passacavo adesivo	Adhesive grommet	Pass-câble adhesive	Kabeldurchgang	Pasacables adhesivo
21	3122550 000	3		Vite 2,9.10 TCIC	Screw 2,9.10 TCIC	Vis 2,9.10 TCIC	Schraube 2,9.10 TCIC	Tornillo 2,9.10 TCIC

Tav.41

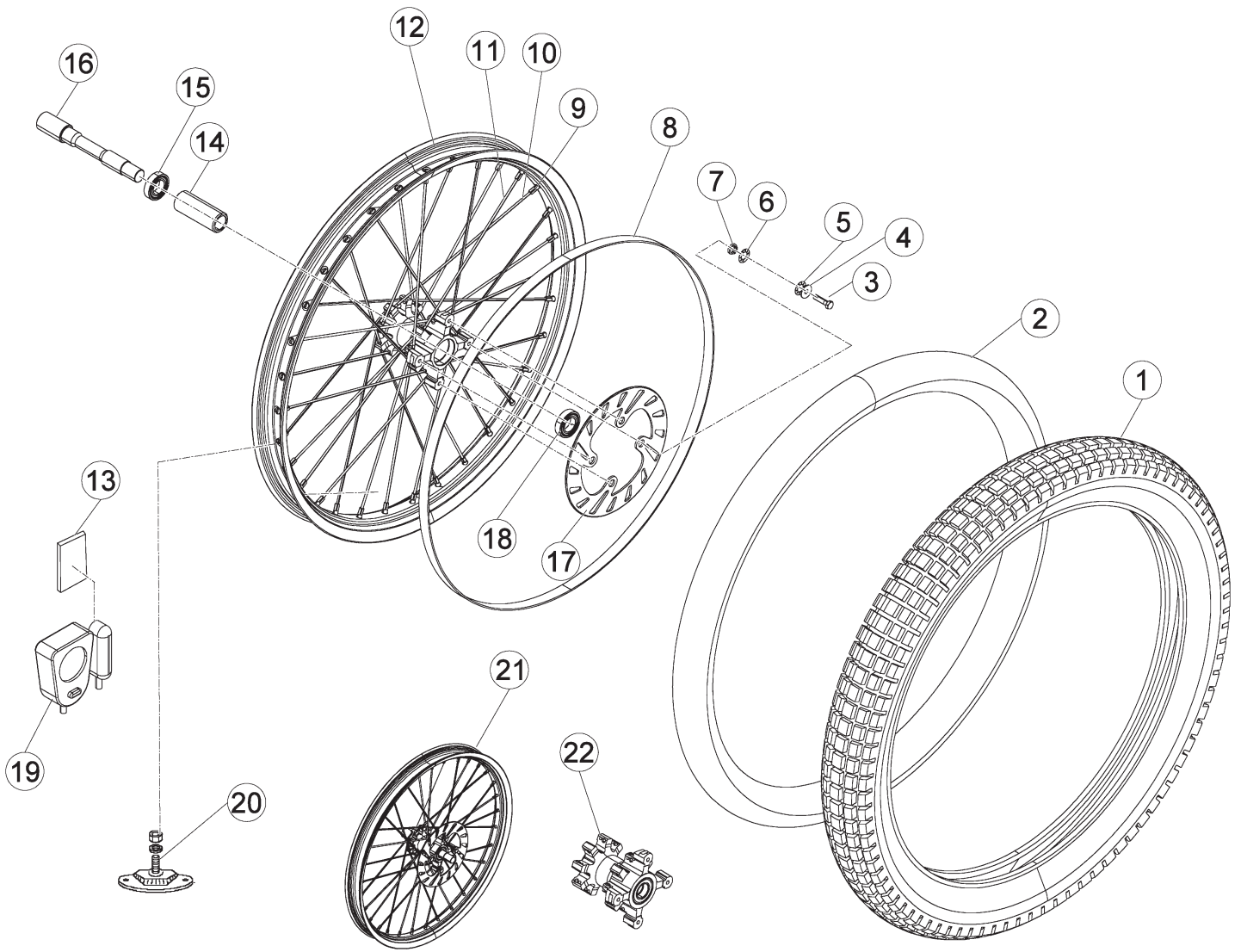

Pos Loc Pos Ps Pos	Numero Number Numéro Número Nummer	Q.tà Q.ty Q.té M.ge C.ad	Nota Note Note Nota Anm.	Descrizione	Description	Désignation	Beschreibung	Descripción
1	1279400 000	1		Copertura	Cover	Couvercle	Abdeckung	Cubierta
2	1216410 000	1		Camera d'aria	Tubular braid	Chambre à air	Schlauch	Camara
3	1149513 000	4		Vite 6.25	Screw 6.25	Vis 6.25	Schraube 6.25	Tornillo 6.25
4	2757510 000	4		Rondella	Washer	Rondelle	U.Scheibe	Arandela
5	2231980 000	4		Molla a tazza	Cup spring	Ressort à diaphragme	Tassenfeder	Muelle
6	2757510 000	4		Rondella	Washer	Rondelle	U.Scheibe	Arandela
7	1362251 000	4		Distanziale	Spacer	Entretoise	Distanzstück	Distanciadador
8	007411140 000	1		Flap 21x25	Bead 21x25	Flap21x25	Felgenband 21x25	Flap cinta tapa radios 21.25
9	007411130 000	32		Nipples	Nipples	Nipples	Nippel	Nipples
10	007411110 000	16		Raggio 3.258	Spoke 3.258	Rayon 3.258	Speiche 3.258	Radio 3.258
11	007411120 000	16		Raggio 3.256	Spoke 3.256	Rayon 3.256	Speiche 3.256	Radio 3.256
12	007410500 000	1		Cerchio 21.1,6-32 foro 8,5	Rim 21.1,6-32 foro 8,5	Jante roue 21.1,6-32 foro 8,5	Felge 21.1,6-32 foro 8,5	Aro 21.1,6-32 foro 8,5
13	007350610 000	1		Tampone in gomma	Rubber pad	Tampon en caoutchouc	Gummipuffer	Silent-block de goma
14	007410030 000	1		Distanziale interno	Inner spacer	Entretoise interne	Inneres Distanzstück	Distanciadador interior
15	1297900 000	1		Cuscinetto 61904	Bearing 61904	Roulement 61904	Lager 61904	Cojinete 61904
16	007410300 000	1		Perno ruota anteriore	Front wheel spindle	Pivot roue AV.	Vorderradzapfen	Perno rueda delantera
17	1339279 000	1		Disco freno ant.	Front brake disk	Disque frein avant	Vorderbrems Scheibe	Disco freno delantero
18	1297900 000	1		Cuscinetto 61904	Bearing 61904	Roulement 61904	Lager 61904	Cojinete 61904
19	007350600 000	1		Contakm digitale	Speedometer	Compteur	Tachometer	Cuenta km. tr.
20	1517500 000	1		Fermafascioni	Tire fastener	Caoutchouc serrure chambre	Reifen Halter	Agarre cubierta ant.
21	007411000 058	1		Ruota anteriore p/montata	Front wheel ass.	Roue avant p/monte'	Vormontiertes vorderrad	Rueda delantera montada
22	007410018 059	1		Mozzo anteriore c/cuscinetti	Front hub with ballbearing	Moyeu avant avec roulements	Nabe vo.	Buje ant.c/cojinetes



Beta
the play bike

Tav.42

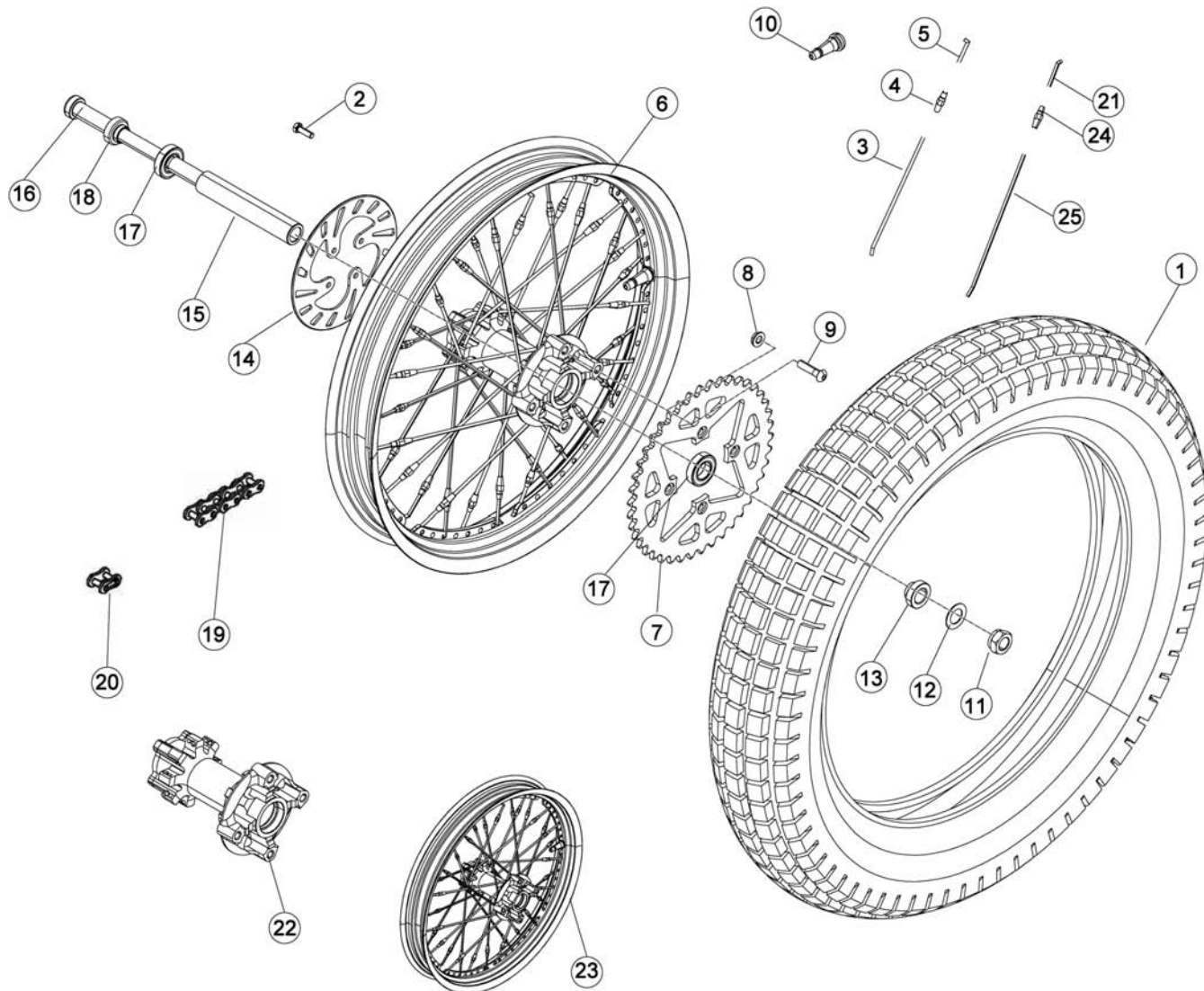

Pos Loc Pos Ps Pos	Numero Number Numéro Número Nummer	Q.tà Q.ty Q.té M.ge C.ad	Nota Note Note Nota Anm.	Descrizione	Description	Désignation	Beschreibung	Descripcìon
1	1281470 000	1		Copertura 4,00.18 TR x-11 tbl	Cover 4,00.18 TR x-11 tbl	Couvercle 4,00.18 TR x-11 tbl	Abdeckung 4,00.18 TR x-11 tbl	Cubierta 4,00.18 TR x-11 tbl
2	007420160 000	4		Vite 6.16 dcrò	Screw 6.16 dcrò	Vis 6.16 dcrò	Schraube 6.16 dcrò	Tornillo 6.16 dcrò
3	007421120 000	16		Raggio 3,5*165	Spoke 3,5*165	Rayon 3,5*165	Speiche 3,5*165	Radio 3,5*165
4	007421140 000	32		Nipples 3,5	Nipples 3,5	Nipples 3,5	Nippel 3,5	Nipples 3,5
5	007421180 000	1		Attacco raggio 3,5*34	Spoke fixing 3,5*34	Fixation du rayon 3,5*34	Speichebefestigung 3,5*34	Sujecìon radio 3,5*34
6	007421500 000	1		Cerchio ruota post.	Rear wheel rim	Jante roue AR.	Hinterradfelge	Llanta ruota trasera
7	1289445 000	1		Corona z42 5/8.1/4	Ring gear z42 5/8.1/4	Couronne z42 5/8.1/4	Zahnkranz z42 5/8.1/4	Corona z42 5/8.1/4
8	1317123 000	4		Dado TECF M8	Nut TECF M8	Ecrou TECF M8	Mutter TECF M8	Tuerca TECF M8
9	007420150 000	4		Vite TBCE M8.33	Screw TBCE M8.33	Vis TBCE M8.33	Schraube TBCE M8.33	Tornillo TBCE M8.33
10	007421600 000	1		Valvola aria	Choke valve	Soupape air	Luftventil	Válvula aire
11	1329602 000	1		Dado asse ruota post.	Rear wheel axle nut	Ecrou axe roue AR.	Mutter Hinterradachse	Tuerca eje ruota tras.
12	2771210 000	1		Rondella 17x33x3	Washer 17x33x3	Rondelle 17x33x3	Scheibe 17x33x3	Arandela 17x33x3
13	007420200 000	1		Distanziale mozzo post.	Spacer rear hub	Entretoise moyeu arriere	Distanzscheibe	Dist. buje tras. der. l/corona
14	007420040 000	1		Disco freno post	Rear brake disk	Disque frein arriere	Hinterbrems-scheibe	Disco freno trasero
15	007420030 000	1		Distanziale interno	Inner spacer	Entretoise interne	Distanzstück	Distanziador interior
16	007420300 000	1		Perno ruota posteriore	Rear wheel pin	Pivot roue arriere	Hinterradbolzen	Perno ruota trasera
17	1298010 000	2		Cuscinetto 20.40.12	Bearing 20.40.12	Roulement 20.40.12	Lager 20.40.12	Cojinete 20.40.12
18	007420200 000	1		Distanziale mozzo post.	Spacer rear hub	Entretoise moyeu arriere	Distanzscheibe	Dist. buje tras. der. l/corona
19	1206771 000	1		Catena speciale 5/8.1/4 P.101	Special chain 5/8.1/4 P.101	Chaîne spéciale 5/8.1/4 P.101	Spezialkette 5/8.1/4 P.101	Cadena especial 5/8.1/4 P.101
20	2211220 000	1		Maglia congiunzione	Connecting link	Maillon jonction	Kettenschloss	Eganche catena
21	007421170 000	16		Attacco raggio 3,5*35	Spoke fixing 3,5*35	Fixation du rayon 3,5*35	Speichebefestigung 3,5*35	Sujecìon radio 3,5*35
22	007420018 059	1		Mozzo posteriore c/cuscinetti	Rear hub with ballbearing	Moyeu arriere avec roulements	Hinterrad Nabe	Buje del. c/cojinetes
23	008421000 058	1		Ruota posteriore p/montata	Front wheel ass.	Roue arriere p/monte'	Vormontiertes hinterrad	Rueda trasera montada
24	007421140 000	32		Nipples 3,5	Nipples 3,5	Nipples 3,5	Nippel 3,5	Nipples 3,5
25	007421130 000	16		Raggio 3,5*175	Spoke 3,5*175	Rayon 3,5*175	Speiche 3,5*175	Radio 3,5*175

Tav.43

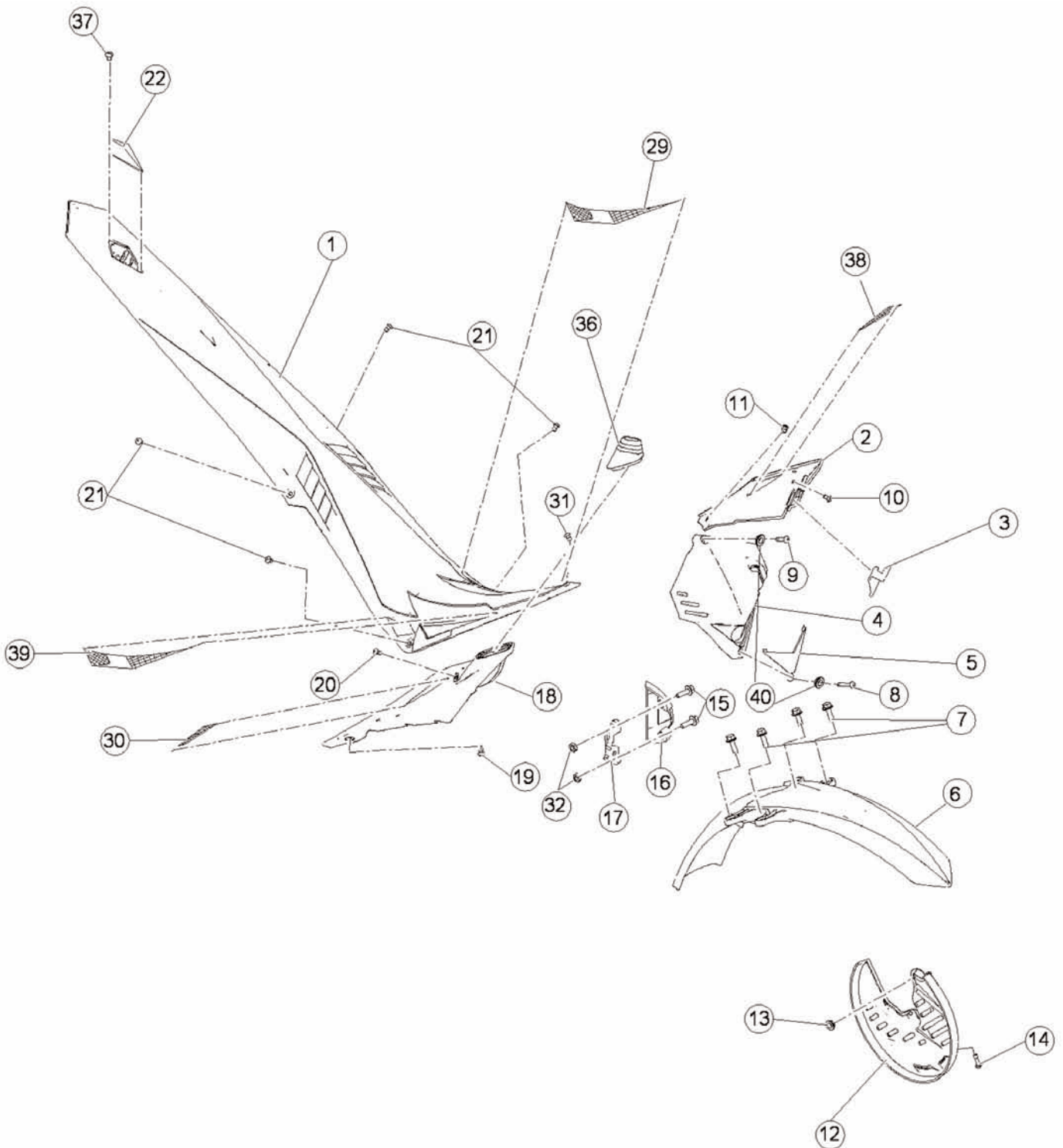

Beta
the play bike

Tav.43

Pos Loc Pos Ps Pos	Numero Number Numéro Número Nummer	Q.tà Q.ty Q.té M.ge C.ad	Nota Note Note Nota Anm.	Descrizione	Description	Désignation	Beschreibung	Descripcìon
1	007433358 097	1	250cc	Parafango posteriore con decalco	Rear mudguard with stickers	Garde-boue AR. avec décalcomanie	Hinterradkotflügel mit kleber	Guardabarros tras. con pegas
1	007433368 097	1	300cc	Parafango posteriore con decalco	Rear mudguard with stickers	Garde-boue AR. avec décalcomanie	Hinterradkotflügel mit kleber	Guardabarros tras. con pegas
2	007430088 097	1		Fianchetto serbatoio sx	LH tank panel	Panneau lateral reservoir gauche	Benzintankseite li.	Flanco izquierdo
3	007430031 097	1		Clip switch mappatura	Mapping switch clip	Clip switch schéma	Clip Speicheraufteilung Switch	Clip switch calibración
4	007432458 097	1		Mascherina	Mask	Masque	Maske	Máscara
5	007430411 000	1		Mascherina portafaro	Headlight holder	Cache porte-phare	Lampenmaske	Portafaro ant. con adhesivo
6	007430118 097	1		Parafango anteriore	Front mudguard	Garde boue AV.	Vorderradkotflügel	Guardabarros anterior
7	1148025 000	4		Bullone 6.16 rs ch 8	Bolt 6.16 rs ch 8	Boulon 6.16 rs ch 8	Bolzen 6.16 rs ch 8	Tornillo 6.16 rs ch 8
8	3129886 000	1		Vite TBCE 5.35	Screw TBCE 5.35	Vis TBCE 5.35	Schraube TBCE 5.35	Tornillo TBCE 5.35
9	3129875 000	1		Vite TBCE 5.25	Screw TBCE 5.25	Vis TBCE 5.25	Schraube TBCE 5.25	Tornillo TBCE 5.25
10	3129810 000	1		Vite 5x12	Screw 5x12	Vis 5x12	Schraube 5x12	Tornillo 5x12
11	3196829 000	1		Vite TCBEI M5x8 10.9	Screw TCBEI M5x8 10.9	Vis TCBEI M5x8 10.9	Schraube TCBEI M5x8 10.9	Tornillo TCBEI M5x8 10.9
12	007430601 059	1		Copridisco anteriore	Disc cover	Couvre-disque	Scheibenabdeckung	Cubredisco
13	1355240 000	1		Distanziale	Spacer	Entretroise	Distanzstück	Distanciadór
14	3129860 000	1		Vite M5x16 TTLIC	Screw M5x16 TTLIC	Vis M5x16 TTLIC	Schraube M5x16 TTLIC	Tornillo M5x16 TTLIC
15	3130020 000	2		Vite M5x25 TCCE	Screw M5x25 TCCE	Vis M5x25 TCCE	Schraube M5x25 TCCE	Tornillo M5x25 TCCE
16	007430511 059	1		Supporto bobina sup.	Upper coil bracket	Support bobine sup.	Ankerplatte Obere, kpl	Soporte bobinas sup.
17	007430501 059	1		Supporto bobina Inf.	Lower coil bracket	Support bobine inf.	Ankerplatte Untere, kpl	Soporte bobinas inf.
18	007430098 097	1		Fianchetto serbatoio dx	RH tank panel	cote lateral reservoir droite	Benzintankseite re.	Flanco derecho deposito
19	3196829 000	1		Vite TCBEI M5x8 10.9	Screw TCBEI M5x8 10.9	Vis TCBEI M5x8 10.9	Schraube TCBEI M5x8 10.9	Tornillo TCBEI M5x8 10.9
20	3129810 000	1		Vite 5x12	Screw 5x12	Vis 5x12	Schraube 5x12	Tornillo 5x12
21	3195510 000	4		Vite M6x12	Screw M6x12	Vis M6x12	Schraube M6x12	Tornillo M6x12
22	1501823 053	1		Fanalino posteriore	Rear combination lamp	Feu AR.	Rücklicht	Piloto
29	007430230 059	1		Griglia sx. parafango post.	LH rear mudguard grille	Calandre G. garde boue AR.	Grill links Hinterradkotflügel	Reja izq. guardabarros tras. der.
30	007430040 059	1		Griglia serbatoio dx	RH tank grill	Grille reservoir droit	Kuehlerverkleidung RE	Junta deposito derecho
31	3195510 000	1		Vite M6x12	Screw M6x12	Vis M6x12	Schraube M6x12	Tornillo M6x12
32	1311000 000	2		Dado M5	Nut M5	Ecrou M5	Mutter M5	Tuerca M5
36	007430010 000	1		Gommino passacavo	Fairlead rubber ring	Joint en caoutchouc passe-câble	Kabeldurchgangsgummi	Junta de goma pasa-cable
37	3122550 000	1		Vite 2,9.10 TCIC	Screw 2,9.10 TCIC	Vis 2,9.10 TCIC	Schraube 2,9.10 TCIC	Tornillo 2,9.10 TCIC
38	007430071 059	1		Fianchetto inf. serbatoio sx	LH tank panel, lower	Panneau lateral inf. reservoir G.	Benzintankseite li. Unten	Flanco izq. inf. deposito
39	007430220 059	1		Griglia dx. parafango post.	RH rear mudguard grille	Calandre D. garde boue AR.	Grill rechts Hinterradkotflügel	Reja der. guardabarros tras. der.

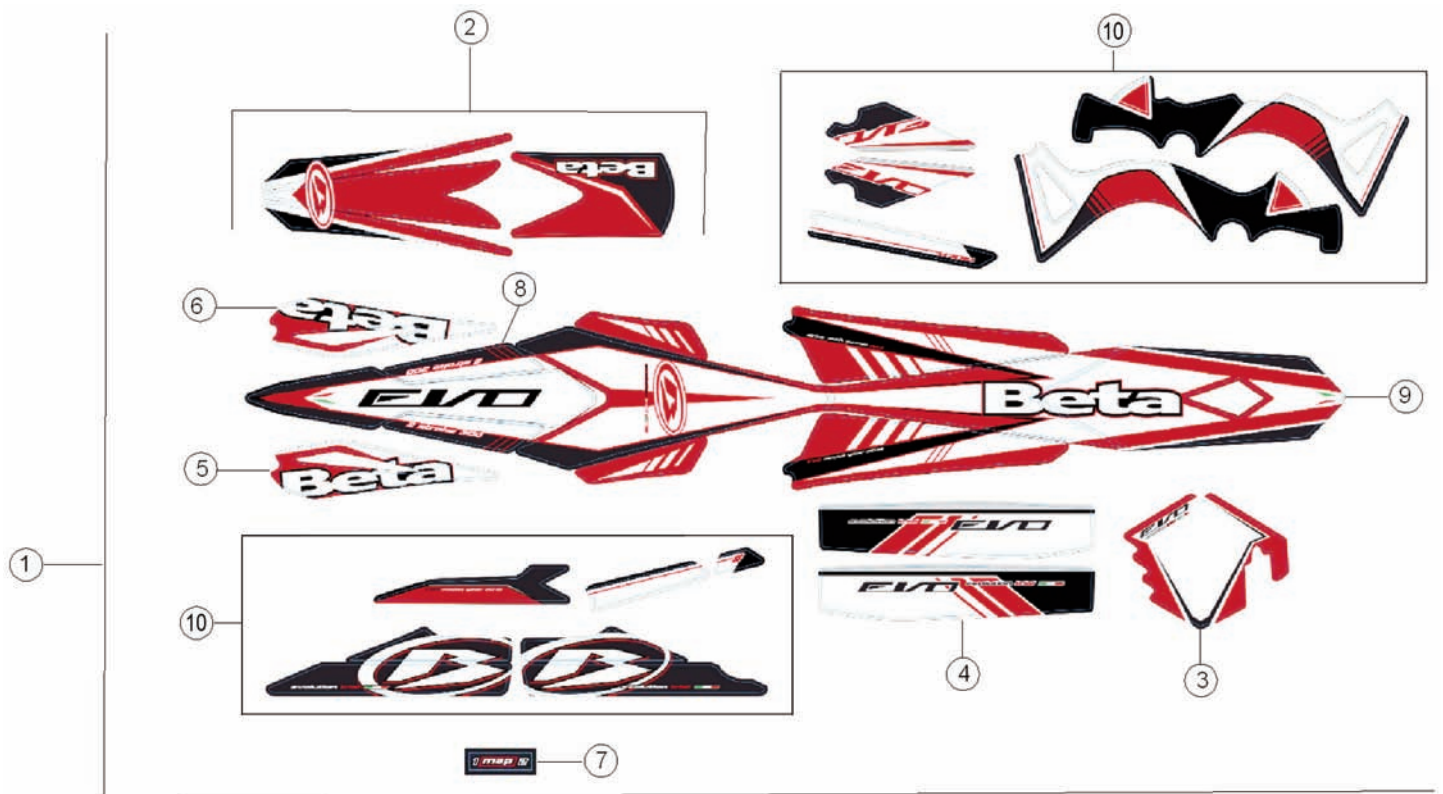

Pos Loc Pos Ps Pos	Numero Number Numéro Número Nummer	Q.tà Q.ty Q.té M.ge C.ad	Nota Note Note Nota Anm.	Descrizione	Description	Désignation	Beschreibung	Descripció
1	007436908 000	1		Kit decalco completo EVO	Transfer set EVO, assy	Jeu decalcomania 2T	Abziehbild 2T	Calcomania 2T
2	007436910 000	1		Decalco parafango ant.	Front mudguard sticker	Décalcomanie garde boue AV.	Vorderradkotflügel Kleber	Pega guardabarros delantero
3	007436930 000	1		Decal. portanumero anteriore	Front trim	Décal. AV.	Vord. Abziehbild	Calcom. delantero
4	007436940 000	1		Decalco per forcellone (coppia)	Transfer set rear fork	Décalcomanies fourche arrière	Paar Abziehbild	Pareja calcomanias
5	007436950 000	1		Decalco fiancata Sx.	Sticker, side panel L.H.	Décalcomanie flanc G.	Kleber Seitenverkleidung links	Pega lateral izq.
6	007436960 000	1		Decalco fiancata Dx.	Sticker, side panel R.H.	Décalcomanie flanc D.	Kleber Seitenverkleidung rechts	Pega lateral der.
7	007434970 000	1		Decalco mappatura	Mapping sticker	Décalcomanie schéma	Kleber Speicheraufteilung	Pega calibración
8	007436986 000	1	250cc	Decalco cilindrata	Displacement sticker	Décalcomanie cylindrée	Kleber Hubraum	Pega cilindrada
8	007436987 000	1	300cc	Decalco cilindrata	Displacement sticker	Décalcomanie cylindrée	Kleber Hubraum	Pega cilindrada
9	007436920 000	1		Decalco parafango post.	Rear mudguard sticker	Décalcomanie garde boue AR.,	Hinterradkotflügel Kleber,	Pega guardabarros trasero
10	007436998 000	1		Decalco telaio EVO 4T '12	Frame transfer set EVO 4T '12	Jeu decalcomanies cadre EVO 4T '12	Abziehbild rahmen EVO 4T, '12	Calcomanias chasis EVO 4T '12



