

RE 125

CATALOGO PARTI DI RICAMBIO
CATALOGUE OF SPARE PARTS
CATALOGUE PIECES DE RECHANGE
ERSATZTEILKATALOG
CATALOGO DE PIEZAS DE REPUESTO

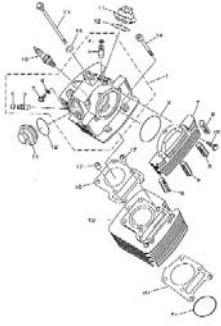

TAV.1 Cilindro - Cylinder - Cylindre - Zylinder - Cilindro



TAV.2 Albero motore-Pistone - Crankshaft-Piston - Vilebrequin-Piston - Kurbelwelle-Kolben - Cigüeñal-Pistón

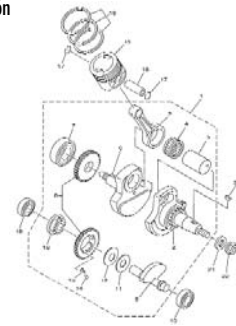

TAV.3 Valvole - Valves - Soupapes - Ventil - Válvulas

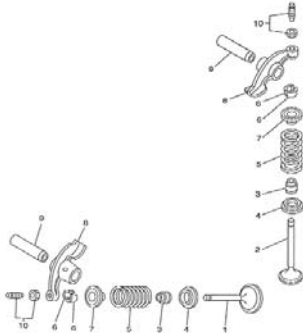

TAV.4 Albero motore - Crankshaft - Vilebrequin - Kurbelwelle - Cigüeñal

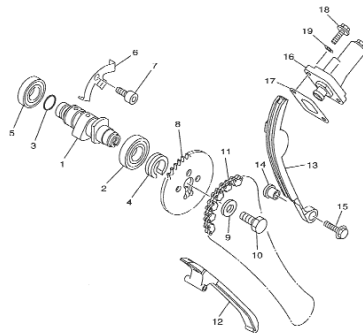

TAV.5 Pompa olio - Oil pump - Pompe d'huile - Ölpumpe - Bomba de aceite

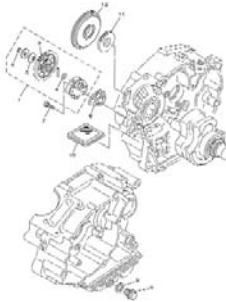

TAV.6 Raccordo d'ammissione - Induction pipe - Raccord d'admission - Ansaugstutzen - Racor de admision

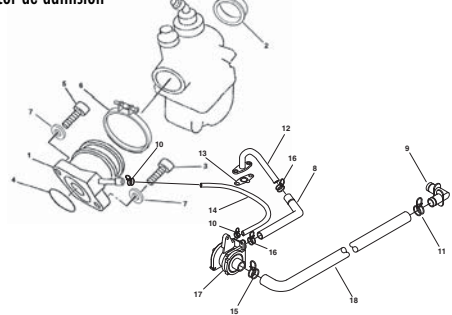

TAV.7 Carburatore - Carburettor - Carburateur - Vergaser - Carburador

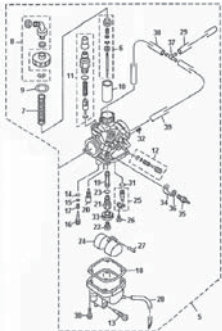

TAV.8 Carter motore - Crankcase assy. - Carter moteur complet - Kurbelgehäuse, compl. - Carter motor completo

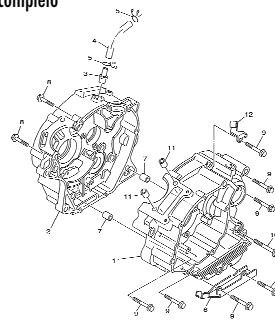

TAV.9 Coperchio frizione - Clutch cover - Couvercle d'embrague - Kupplungsdeckel - Tapa embrague

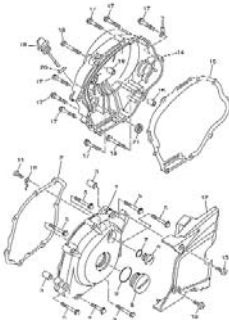

TAV.10 Leva messa in moto - Start. lever - Levier du démarrage - Kickstarterhebel - Palanca de arranque

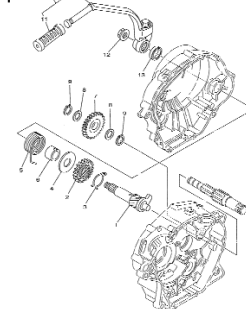

TAV.11 Motorino avviamento - Starting motor - demarreur electrique - Anlassermotor - Motor de arranque

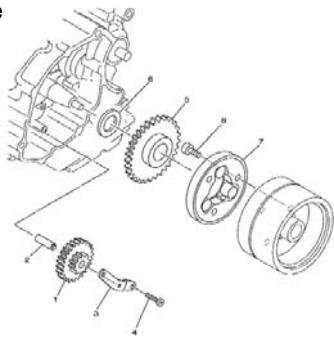

TAV.13 Ingranaggi Cambio - Gear group - Engrenages changement de vitesses - Schaltgetriebe - Engranaje del cambio

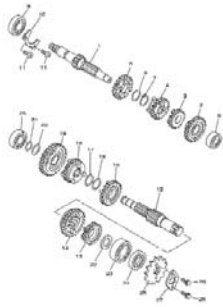

TAV.15 Comando cambio - Gear shift control - Commande changement de vitesse - Chaltung - Mando cambio

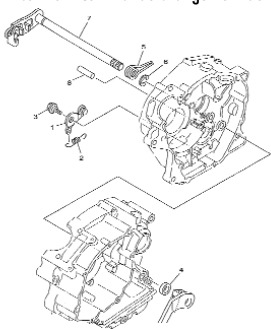

TAV.17 Motorino avviamento - Starting motor - demarreur electrique - Anlassermotor - Motor de arranque

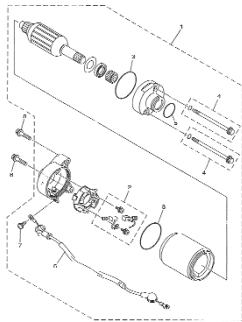

TAV.19 Forcella anteriore - Front fork - Fourche AV. - Vorderradgabel - Horquilla delantera

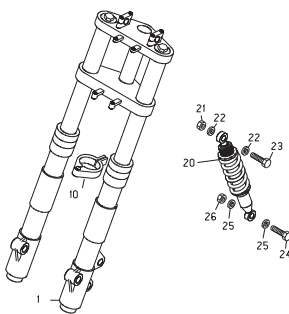

TAV.12 Frizione - Clutch - Embrayage - Kupplung - Embrague

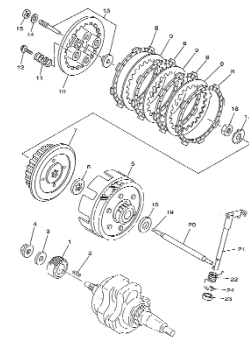

TAV.14 Comando cambio - Gear shift control - Commande changement de vitesse - Chaltung - Mando cambio

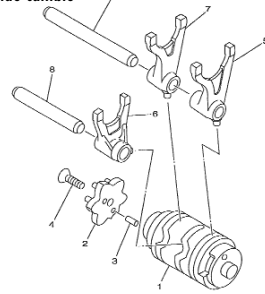

TAV.16 Volano magnete - Flywheel magneto - Volant magnetique - Lichtmaschine - Volante magnetico

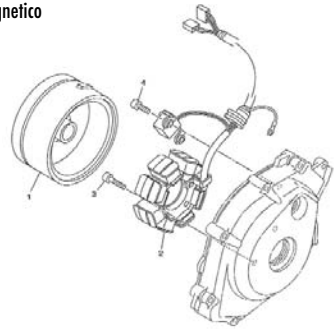

TAV.18 Dispositivi elettrici - Electrical devices - Dispositifs electriques - Elektrische Ausrüstung - Dispositivos electricos

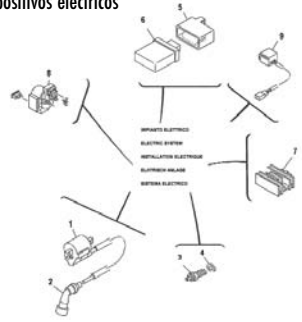

TAV.19A Forcella anteriore - Front fork - Fourche AV. - Vorderradgabel - Horquilla delantera

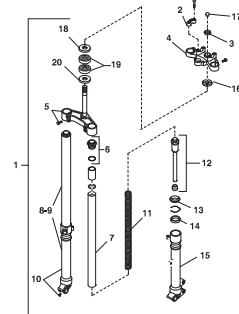

TAV.20 Manubrio - Handlebars - Guidon - Lenker - Manillar

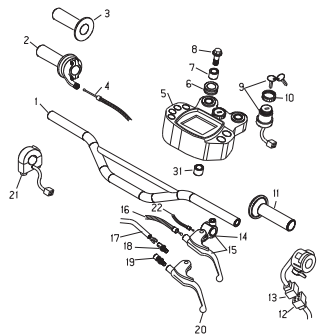

TAV.29 Carenature - Fairings - Carenages - Verkleidungen - Carenados

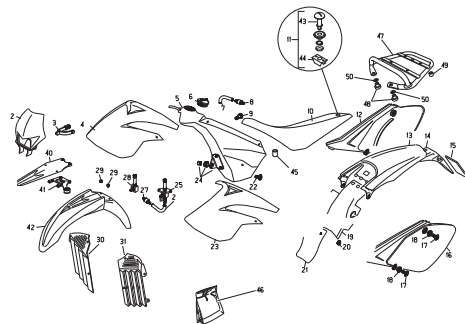

TAV.21 Forcellone posteriore - Rear fork - Fouche arriere - Hinterradschwinge - Horquilla posterior

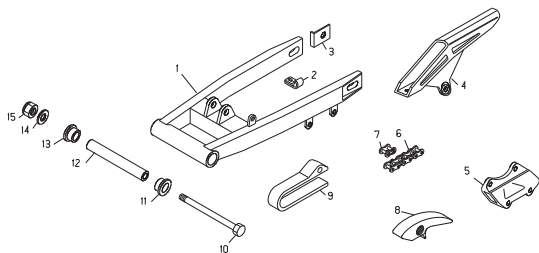

TAV.22 Telaio-Cavalletto - Chassis-Central stand - Châssis-Bequille - Rahmen-Ständer - Chasis-Caballette

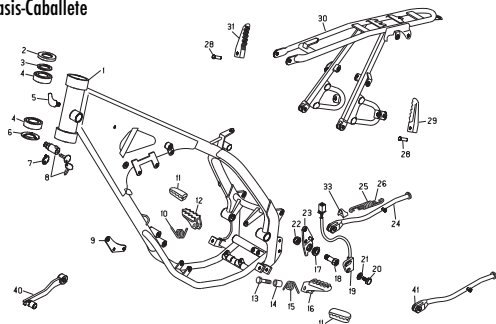

TAV.23 Marmitta - Silencer - Silencieux - Auspufftopf - Silenciador

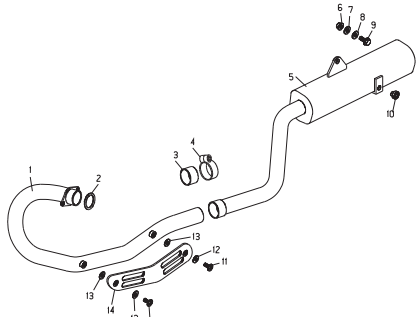

TAV.24 Filtro aria - Air filter - Filtre à air - Luftfilter - Filtro de aire

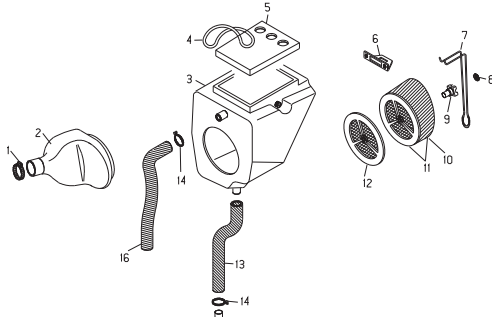

TAV.25 Ruota anteriore - Front wheel - Roue AV. - Vorderrad - Rueda delantera

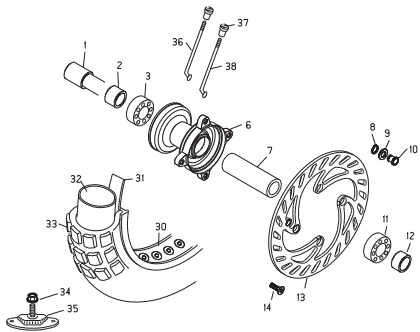

TAV.26 Ruota posteriore - Rear wheel - Roue AR. - Hinterrad - Rueda trasera

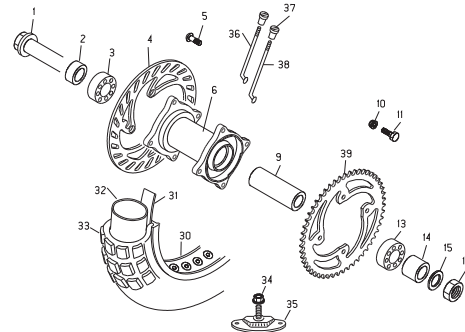

TAV.27 Impianto freno anteriore - Front brake system - Circuit de frein AV. - Vordere Bremsanlage - Instalación freno delantero

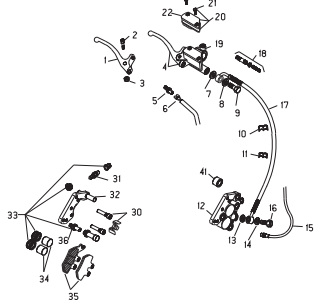

TAV.28 Impianto freno posteriore - Rear brake system - Circuit de frein AR. - Hintere Bremsanlage - Instalación freno trasero

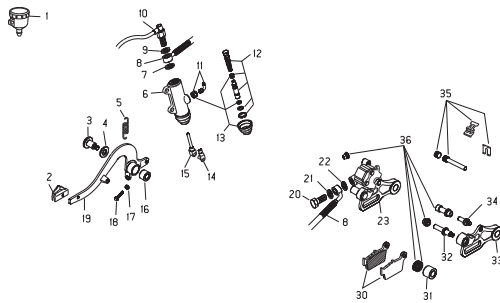

TAV.30 Dispositivi elettrici - Electrical devices - Dispositifs électriques - Elektrische Ausrüstung - Dispositivos eléctricos

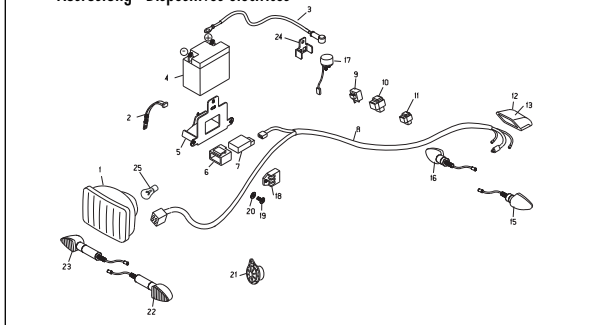

TAV.31 Particolari non figuranti - Supplementary parts list - Particuliers pas mentionnées - Nicht Verzeichnete teile - Particulares no figurados

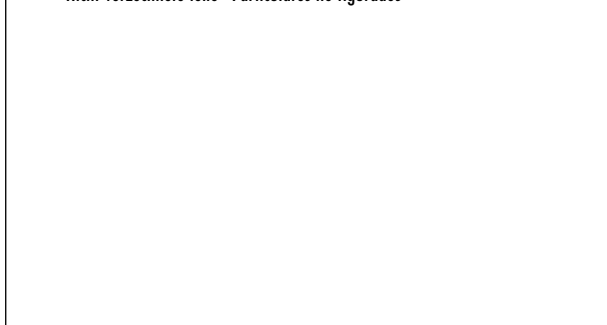

Tav.1

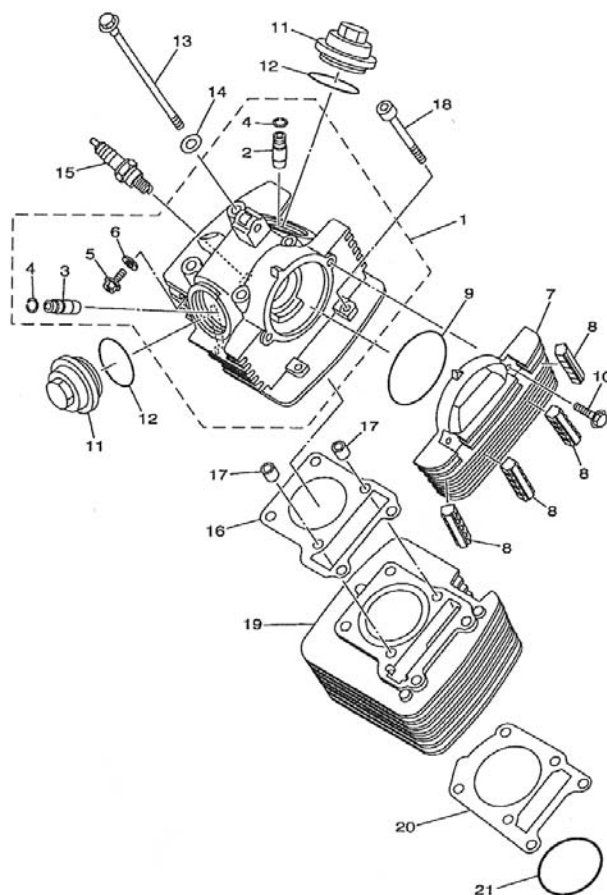

Pos Loc Pos Ps Pos	Numero Number Número Número	Nota Note Nota Anm.	Descrizione	Description	Désignation	Beschreibung	Descripció
1	3404006 100		Testa Cilindro	Cylinder head	Culasse	Zylinder Kopf	Culata
2	3404004 100		Guida Valvole Aspirazione	Intake Valve Guide	Guide de Soupapes d'Admission	Ventilführung - Einlass	Guía Válvulas Aspiración
3	3404003 100		Guida Valvole Scarico	Exhaust Valve Guide	Guide de Soupapes d'Echappement	Ventilführung - Auslass	Guía Válvulas Escape
4	3404019 100		Seeger (22f)	Circlip (22f)	Circlip (22f)	Seeger (22f)	Seeger (22f)
5	3404014 100		Vite	Screw	Vis	Schraube	Tornillo
6	3404015 100		Guarnizione	Packing	Joint	Dichtung	Junta
7	3404008 100		Coperchio Testa, Collettore	Head Cover, Manifold	Couvercle Culasse, Collecteur	Zylinderkopfdeckel, Krümmer	Tapa Culata, Colector
8	3404007 100		Gommino Antivibrazione Testa	Head Vibration Damper Pad	Plot Antivibration Culasse	Schwingungsdämpfergummi Zylind.	Goma Antivibración Culata
9	3404018 100		Anello Or Bocchettone Scarico	Drain Union O-ring	Joint Torique Pot d'Echappement	O-Ring für Auslassstutzen	Anillo Or Boca Escape
10	3404025 100		Bullone Flangiato Bocchet.Scarico	Drain Union Flanged Bolt	Boulon Bridé Pot d'Echappement	Bundbolzen für Auslass	Bulón con Brida Boca Escape
11	3404009 100		Tappo Testa, Ispezione Valvole	Head Cap, Valve Inspection	Bouchon Culasse, Visite Soupapes	Zyl.kopfverschluss für Ventilinsp.	Tapón Culata, Inspección Válvulas
12	3404016 100		Anello Or Tappo Ispez. Valvole	Valve Insp Cap O-ring	Joint Torique Visite Soupapes	O-Ring Ventilinspektionsverschluss.	Anillo Or Tapón Inspec. Válvulas
13	3404012 100		Bullone Flangiato	Head Flanged bolt	Boulon Bridé Culasse	Bundbolzen für Zylinderkopf	Bulón con Brida Culata
14	3404240 100		Rondella Bullone Fissaggio	Head Retaining Bolt Washer	Rondelle Boulon Fixation	Unterlegscheibe für	Arandela Bulón Fijación
15	3404020 100		Candela Cr6 Hsa	Spark Plug Cr6 Hsa	Bougie Cr6 Hsa	Zündkerze Cr6 Hsa 125cm3	Bujia Cr6 Hsa
16	3404005 100		Guarnizione Cilindro Testa	Head/Cylinder Gasket	Joint Cylindre Culasse	Zylinderkopfdichtung	Junta Cilindro Culata
17	3404232 100		Grano Di Riferimento Cilindro	Cylinder Reference Dowel	Pion de Repère Cylindre	Zentrierstift für Zylinder	Espiga de Referencia Cilindro
18	3404013 100		Bullone C/Esagono Testa	Head Hex Bolt	Boulon Six-pans Culasse derkopf	Sechskantbolzen Zylinder	Bulón con Hexágono Culata
19	3404010 100		Cilindro	Cylinder	Cylindre	Zylinder	Cilindro
20	3404011 100		Guarnizione Cilindro	Cylinder gasket	Garniture cylindre	Zylinderdichtung	Junta cilindro
21	3404017 100		Anello Or Cilindro	Cylinder O-ring	Joint Torique Cylindre	O-Ring für Zylinder	Anillo Or Cilindro



Beta
the play bike

Tav.2

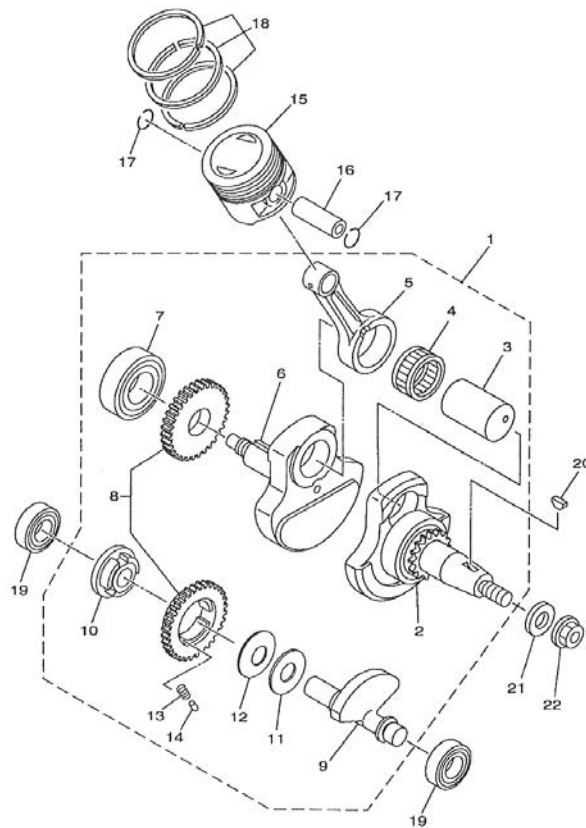

Pos Loc Pos Ps Pos	Numero Number Número Número	Nota Note Nota Anm.	Descrizione	Description	Désignation	Beschreibung	Descripción
1	3404125 100		Albero Motore Completo	Crankshaft, assy.	Arbre moteur complet	kurbelwelle, komplett	Cigüeñal completo
2	3404127 100		Semialbero Frizione	Clutch Half Shaft	Demiarbre Embrayage	Kupplungsachswelle	Semi-eje Embrague
3	3404024 100		Asse Accoppiamento	Coupling Axle	Axe Accouplement Passachse .	assachse .	Eje Acoplamiento
4	3404029 000		Gabbia Per Biella	Cage for Con-Rod	Cage Pour Bielle	Käfig für Pleuel .	aula Para Biela
5	3404023 100		Biella	Conn.-rod	Bielle	Pleuel	Biela
6	3404126 100		Semialbero Volano	Flywheel Half Shaft	Demi-arbre Volant moteur	Schwungradachswelle	Semi-eje Volante
7	3404028 100		Cuscinetto Albero Motore	Crankshaft Bearing	Palier de Vilebrequin	Kurbelwellenlager 125cm3	Cojinete Cigüeñal
8	3404124 100		Ingranaggio Guida, Albero Motore	Drive Gear, Crankshaft	Pignon de Guidage, Vilebre-	Führungsrad, Kurbelwelle	Engranaje Guía, Cigüeñal
9	3404026 100		Albero Bilanciamento Compl.	Compl. Balancer Shaft	Arbre Equilibrage Complet	Kompl. Ausgleichswelle	Árbol Equilibrado Compl.
10	3404259 100		Boccola	Bush	Moyeu	Büchse	Buje
11	3404260 100		Rondella	Washer	Rondelle	U.Scheibe	Arandela
12	3404261 100		Rondella	Washer	Rondelle	U.Scheibe	Arandela
13	3404257 100		Molla	Spring	Ressort	Feder	Muelle
14	3404258 100		Perno	Pin	Pivot	Zapfen	Perno
15	3404022 100		Pistone	Piston	Piston	Kolben	Pistón
16	3404021 100		Spinotto Per Pistone	Piston pin	Axe de piston	Kolbenbolzen	Bulón
17	3404030 100		Seeger (std)	Circlip (std)	Circlip (std)	Seeger (std)	Seeger (std)
18	3404186 100		Segmenti Per Pistone Standard	Rings for Standard Piston	Segments Pour Piston Standard	Kolbenringe für Standardkolben	Segmentos Para Pistón Estándar
19	3404243 100		Cuscinetto Albero Bilanciamento	Balancer Shaft Bearing	Roulement Arbre Equilibrage	Ausgleichswellenlager	Cojinete Árbol Equilibrado
20	3404050 100		Chiavetta Semialbero Frizione	Clutch Half Shaft	Clavette Demi-arbre Embrayage	Federkeil Kupplungswellenachse	Chaveta Semi-eje Embrague
21	3404086 100		Rondella	Washer	Rondelle	U.Scheibe	Arandela
22	3404128 100		Dado Flangiato Albero Motore	Crankshaft Flanged Nut	Ecrou Bridé Vilebrequin	Geflanschte Mutter für Kurbelwelle	Tuerca con Brida Cigüeñal

Tav.3

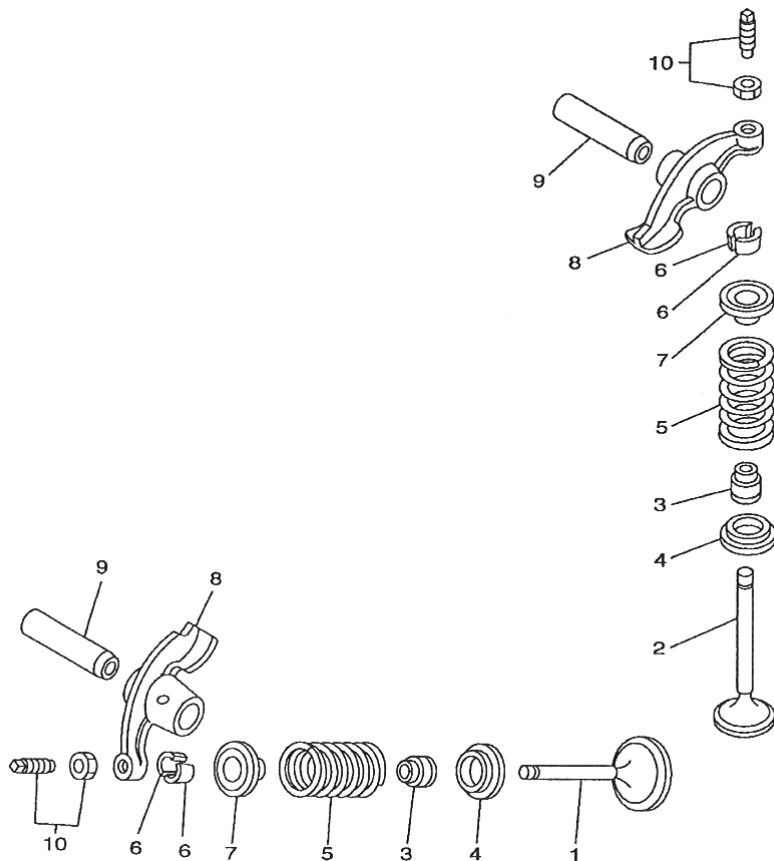

Pos Loc Ps Pos	Numero Number Número Número	Nota Note Nota Anm.	Descrizione	Description	Désignation	Beschreibung	Descripcìon
1	3404043 100		Valvola Aspirazione	Suction valve	Soupape aspir.	Einlaßventil	Válvula aspiración
2	3404044 100		Valvola Scarico	Exhaust valve	Soupape d'éch.	Auslaßventil	Válvula de escape
3	3404035 100		Gambo Valvola	Valve Stem	Queue de Soupape	Ventilschaft	Pata Válvulas
4	3404031 100		Sede Molla Valvole Scarico/Aspirazione	Exhaust/Intake Valve Spring/Seat	Siège Ressort Soupape d'Echappement/Admission	Federsitz Auslass-/Einlassventile	Alojamiento Muelle Válvulas Escape/Aspir
5	3404038 100		Molla Valvola	Valve spring	Ressort soupape	Ventilfeder	Muelle válvula
6	3404033 100		Raccogliatore Valvole	Valve Pan	Ramasseur de Soupapes	Ventilfänger	Recolector Válvulas
7	3404032 100		Ritorno Molla Valvole	Return, Valve Spring	Retour Ressort Soupapes	Ventilfederrückzug 125cm3	Retorno Muelle Válvulas
8	3404037 100		Braccio Valvole Aspiraz./ Scarico	Intake/Exhaust Valve Arm	Tige Soupapes d'Admission/ Echappement	Arm Einlass-/Auslassventile	Brazo Válvulas Aspirac / Escape
9	3404187 100		Albero Guida Braccio Valvola	Valve Arm Guide Shaft	Axe de Guidage Tige Sou-	Ventilarmführungswelle	Arbol Guía Brazo Válvula
10	3404034 100		Vite+Dado Regolazione Valvole	Valve adjuster screw+nut	Vis+ecrou de réglage soupapes	Ventilregelschraube+mutter	Tornillo+tuerca regulación válvulas



Tav.4

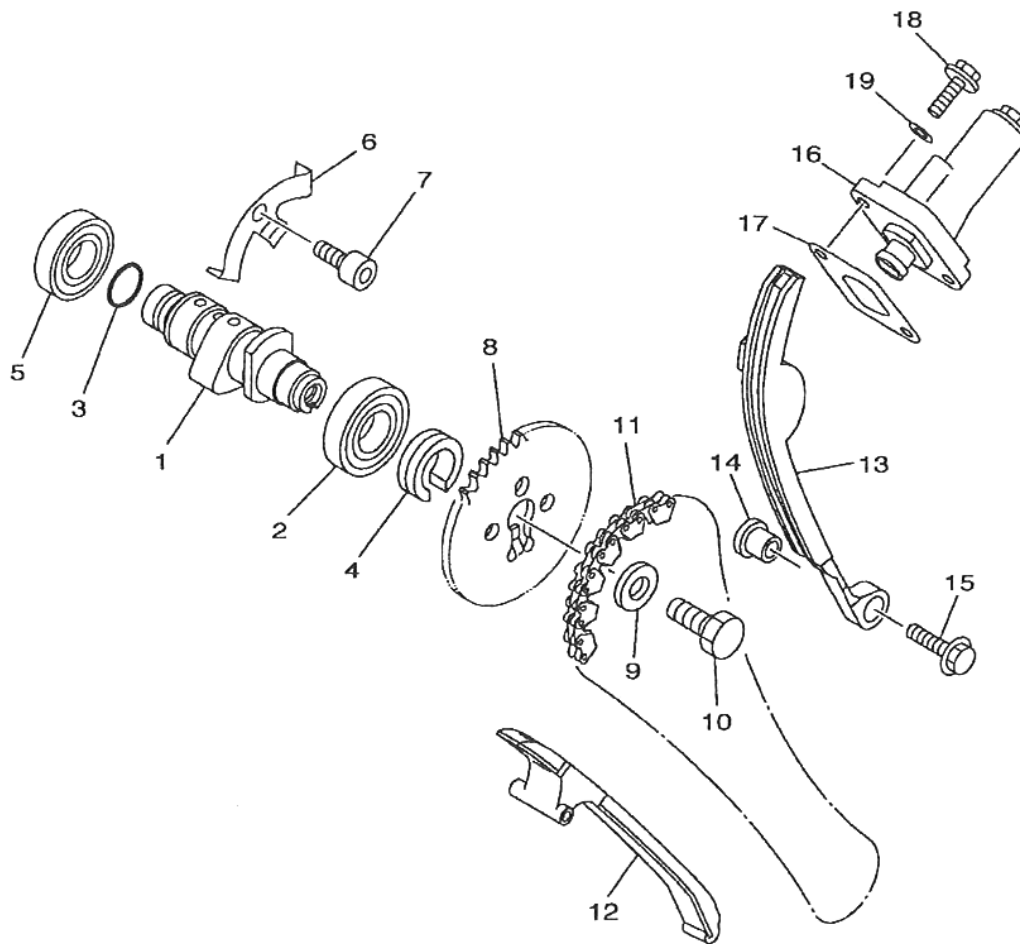

Pos Loc Pos Ps Pos	Numero Number Numéro Número Nummer	Nota Note Note Nota Anm.	Descrizione	Description	Désignation	Beschreibung	Descrìption
1	3404040 100		Albero A Camme Completo	Complete Camshaft	Arbre à Cames Complet	Komplette Nockenwelle	Árbol de Levas Completo
2	3404262 100		Cuscinetto	Bearing	Roulement	Lager	Cojinete
3	3404263 100		Anello or	Ring	Bague d'étanchéité	O-Ring	Anillo OR
4	3404264 100		Collarino	Clamp	Collier	Schelle	Collar
5	3404265 100		Cuscinetto	Bearing	Roulement	Lager	Cojinete
6	3404039 100		Piastrina Albero A Camme	Camshaft Plate	Plaquette Arbre à Cames	Nockenwellenplättchen	Plaqueta Árbol de Levas
7	3404049 100		Bullone Piastrina Alb. A Camme	Camshaft Plate Bolt	Boulon Plaquette Arbre à Cames	Bolzen für Nockenwellenplättchen	Bulón Plaqueta Árbol de Levas
8	3404129 100		Corona Catena Trasmissione	Drive Chain Gearwheel	Couronne Chaîne Transmission	Antriebskettenblatt	Corona Cadena Transmisión
9	3404047 100		Rondella bullone albero a camme	Camshaft bolt washer	Boulon plaquette arbre à cames	U.scheibe für nocken wellenbolzen	Arandela para bulón arbol de levas
10	3404045 100		Bullone C/Esagono Albero A Camme	Camshaft Hex Bolt	Boulon Six-pans Arbre à Cames	Sechskantbolzen Nockenwelle	Bulón con Hexágono Árbol de Levas
11	3404050 100		Catena Trasmissione	Drive Chain	Chaîne transmission	Antriebskette	Cadena Transmisión
12	3404130 100		Guida Catena Trasmissione Inf.	Lwr Drive Chain Guide	Guide de Chaîne Transmission inf	Untere Antriebskettenführung	Guía Cadena Transmisión Inf.
13	3404131 100		Guida Catena Trasmissione Sup.	Upr Drive Chain Guide	Guide de Chaîne Transmission sup	Obere Antriebskettenführung	Guía Cadena Transmisión Sup.
14	3404042 100		Distanziale tensionatore catena	Drive chain tensioner spacer	Entretoise tension chaîne	Abstandstück antriebskettenspanner	Separador tensor cadena
15	3404052 100		Bullone Flangiato	Head Flanged bolt	Boulon Bridé Culasse	Bundbolzen für Zylinderkopf	Bulón con Brida Culata
16	3404036 100		Tensionatore Catena Trasmissione	Drive Chain Tensioner	El. de Mise en Tension Chaîne de Transmission	Antriebskettenspanner	Tensador Cadena Transmisión
17	3404041 100		Guarnizione	Packing	Joint	Dichtung	Junta
18	3404051 100		Bullone Flangiato	Head Flanged bolt	Boulon Bridé Culasse	Bundbolzen für Zylinderkopf	Bulón con Brida Culata
19	3404048 100		Guarnizione	Packing	Joint	Dichtung	Junta

Tav.5

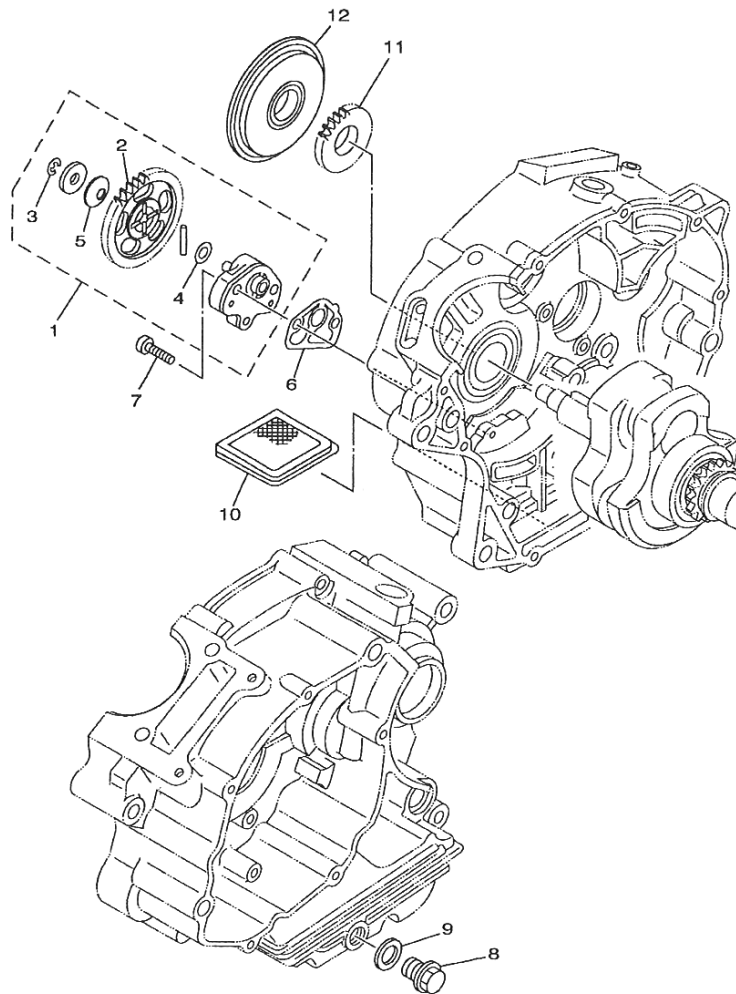

Pos Loc Pos Ps Pos	Numero Number Numéro Número Nummer	Nota Note Note Nota Anm.	Descrizione	Description	Désignation	Beschreibung	Descripción
1	3404133 100		Pompa Olio Completa	Complete Oil Pump	Pompe à Huile Complète	Komplette Ölpumpe	Bomba Aceite Completa
2	3404053 100		Ingranaggio Guidato Pompa Olio	Oil Pump Driven Gear	Engrenage Guidé Pompe à Huile	Geführtes Ölpumpenrad	Engranaje Guiado Bomba Aceite
3	3404244 100		Seeger	Circlip	Circlip	Seeger	Seeger
4	3404057 100		Rondella Conica Pompa Olio	Oil Pump Taper Washer	Rondelle Conique Pompe à Huile	Kegelscheibe f. Ölpumpe	Arandela Cónica Bomba Aceite
5	3404056 100		Rondella Pompa Olio	Oil Pump Washer	Rondelle Pompe à Huile	Unterlegscheibe f. Ölpumpe	Arandela Bomba Aceite
6	3404054 100		Guarnizione coperchio pompa olio	Oil pump cover gasket	Joint couvercle pompe huile	Dichtung Ölpumpeabdeckung	Junta tapa bomba aceite
7	3404055 100		Vite Fissaggio Pompa Olio	Oil Pump Rtnq Screw	Vis de Fixation Pompe à Huile	Befestigungsschraube f. Ölpumpe	Tornillo Fijación Bomba Aceite
8	3404058 100		Tappo Di Scarico Olio	Oil Drain Plug	Bouchon de Vidange huile	Ölablassschraube T.	Tapón de Descarga Aceite
9	3404059 100		Guarnizione Tappo Di Scarico Olio	Oil Drain Plug Seal	Joint Bouchon de Vidange Huile	Dichtung für Ölablassschraube	Junta Tapón de Descarga Aceite
10	3404135 100		Filtro A Rete Scarico Olio	Oil Drain Mesh Filter	Crépine de Filtration Vidange	Ölsieb im Ablass Huile	Filtro de Red Descarga Aceite T.
11	3404134 100		Ingranaggio Guida Pompa Olio	Oil Pump Drive Gear	Engrenage de Guidage Pompe à Huile	Ölpumpenführungsrad	Engranaje Guía Bomba Aceite
12	3404136 100		Filtro Pompa Olio	Oil Pump Filter	Filtre Pompe à Huile	Ölpumpenfilter	Filtro Bomba Aceite



Tav.6

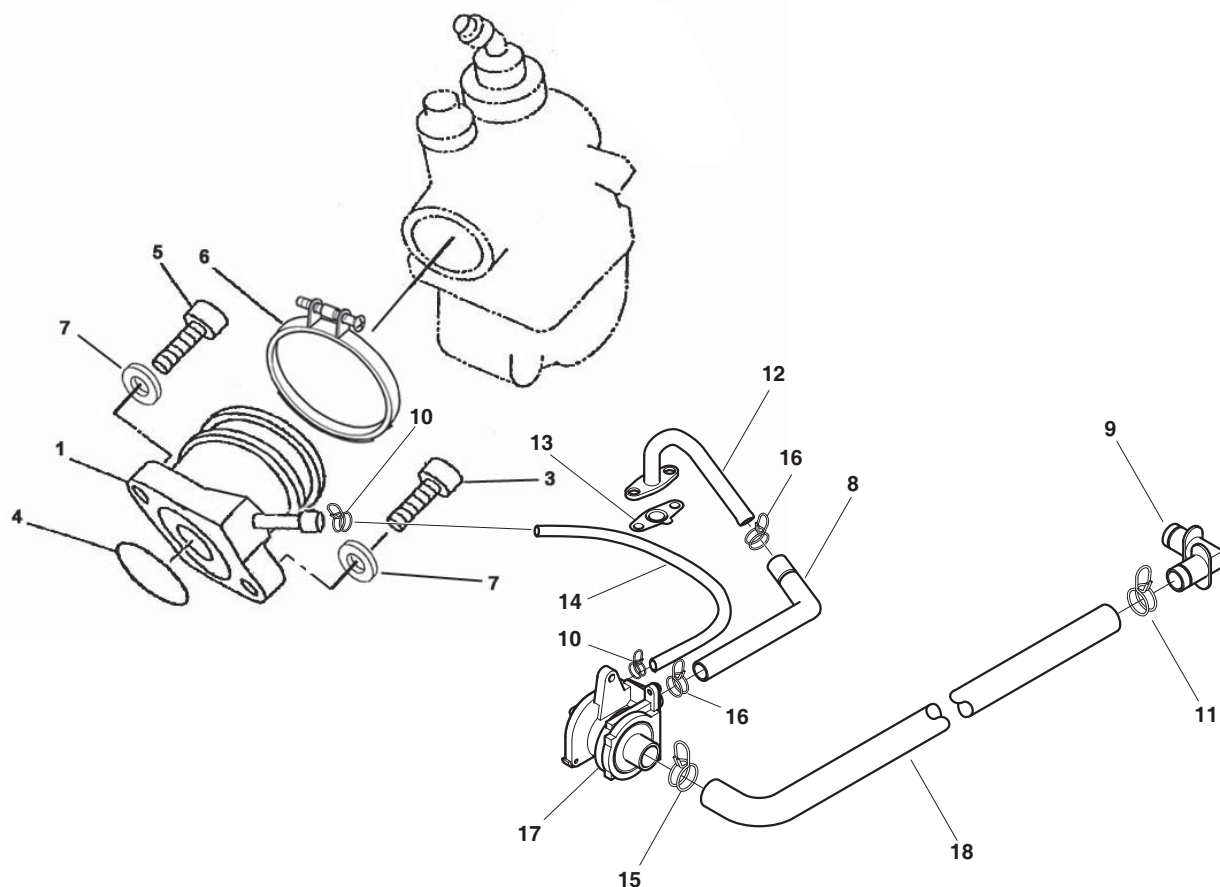

Pos Loc Pos Ps Pos	Numero Number Número Nummer	Nota Note Note Nota Anm.	Descrizione	Description	Désignation	Beschreibung	Description
1	2719795 000		Raccordo carburatore	Carburettor Union	Raccord Carburateur	Vergaseranschluss	Empalme Carburador
3	3402180 000		Vite TCB M6X20	Screw TCB M6X20	Vis TCB M6X20	Schraube TCB M6X20	Tornillo TCB M6X20
4	3404190 000		Anello Or	Ring	Bague d'étanchéité	O-Ring	Anillo OR
5	3134510 000		Vite t.c.c.e. M6x20	Screw t.c.c.e M6x20	Vis t.c.c.e M6x20	Schraube t.c.c.e M6x20	Tornillo t.c.c.e M6x20
6	1514273 000		Fascetta fissaggio carb.	Carb Clamp	Collier de Fixation Carburateur	Vergaserbefestigungsschelle	Abrazadera Fijación Carb.
7	2740500 000		Rondella 6x13	Washer 6x13	Rondelle 6x13	U.Scheibe 6x13	Arandela 6x13
8	2915873 000		Tubo valvola/scarico	Valve/exhaust pipe	Tuyau soupape/échapp.	Leitung Ventil/Auspuffrohr	Tubo válvula/escape
9	2711020 000		Raccordo 90°	Joint p. 90°	Raccord 90°	Stutzen 90°	Racor 90°
10	1067420 000		Anello stringitubo	Pipe clamping ring	Anneau serre-tube	Schlauchschelle	Anillo prensatubo
11	1067470 000		Anello stringitubo	Pipe clamping ring	Anneau serre-tube	Schlauchschelle	Anillo prensatubo
12	2915877 000		Tubo ingresso aria	Tuyau entrée air	Air intake pipe	Luftzufuhrleitung	Tubo entrada aire
13	1680819 000		Guarnizione alluminio	Aluminium gasket	Garniture aluminium	Aluminium-Dichtung	Junta aluminio
14	2915962 000		Tubo 3/8"	Pipe 3/8"	Tuyau 3/8"	Rohr 3/8"	Tubo 3/8"
15	1067450 000		Anello stringitubo CE	Pipe clamping ring CE	Anneau serre-tube CE	Schlauchschelle CE	Anillo prensatubo CE
16	1067435 000		Anello stringitubo	Pipe clamping ring	Anneau serre-tube	Schlauchschelle	Anillo prensatubo
17	3115060 000		Valvola AIS	AIS Valve	Soupape AIS	Ventil AIS	Válvula AIS
18	2915875 000		Tubo valvola/filtro	Valve/filter pipe	Tuyau soupape/filtre	Leitung Ventil/Filter	Tubo válvula/filtro

Tav.7

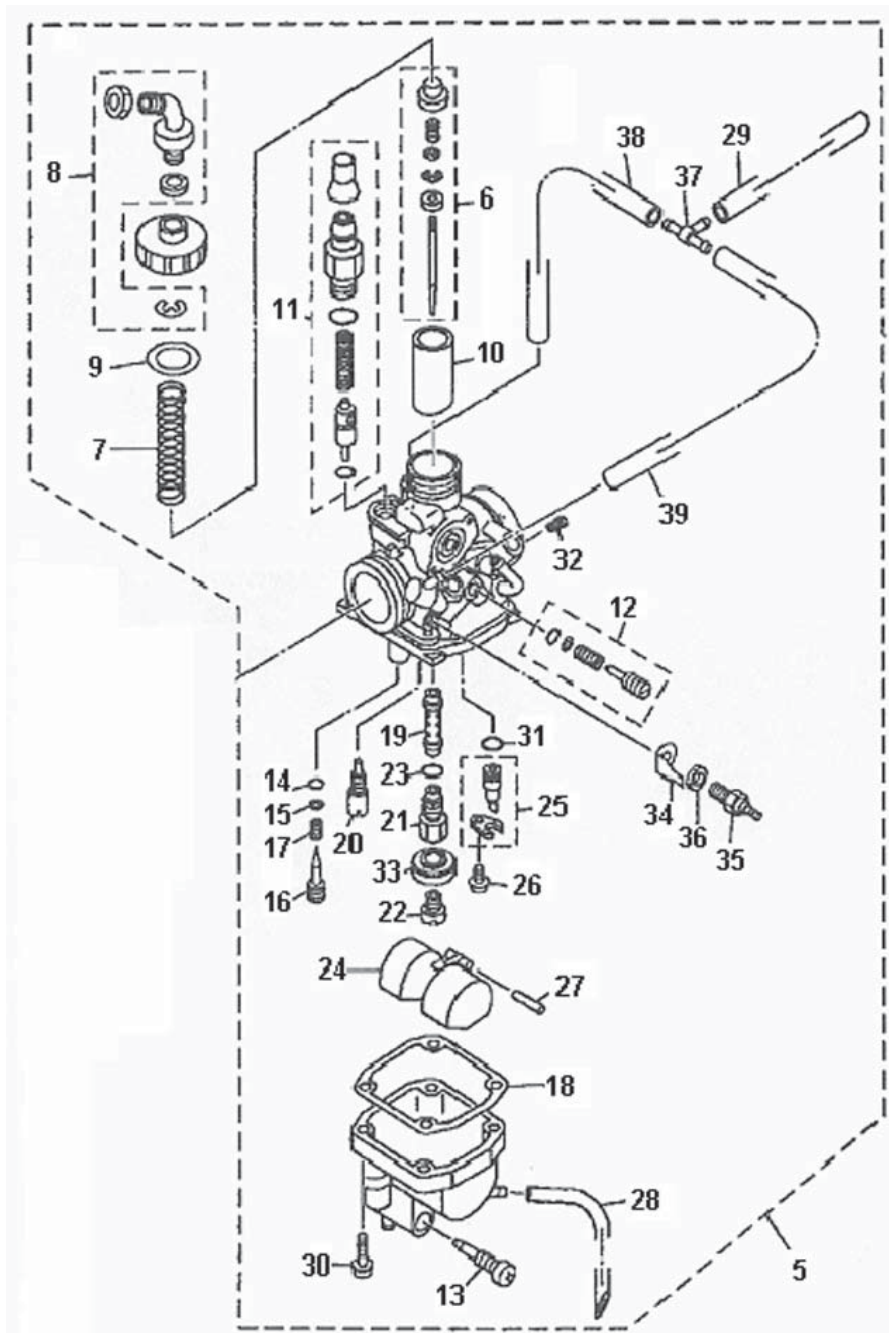

Tav.7

Pos Loc Pos Ps Pos	Numero Number Número Número	Nota Note Nota Anm.	Descrizione	Description	Désignation	Beschreibung	Descripción
5	1204917 000		Carburatore Completo	Carburettor assy.	Carburateur complet	Vergaser, komplett	Carburador completo
6	3404269 100		Kit spillo conico	Conical needle kit	Kit pointeau con.	Kit Nadelventil	Kit aguja con.
7	3404193 000		Molla Valvola Carb.	Carb Valve Spring	Ressort Soupape Carburateur	Vergaserventilfeder	Muelle Válvula Carb.
8	3404194 100		Raccordo	Joint.p.	Raccord	Stutzen	Racor
9	3404195 000		Guarnizione Carb.	Carb Gasket	Joint Carburateur	Vergaserdichtung	Junta Carb.
10	3404271 100		Valvola	Valve	Volet de gaz	Ventil	Válvula gas
11	3404270 100		Dispositivo starter	Starter unit	Dispositif starter	Startervorrichtung	Dispositivo estrang. aire
12	3404198 000		Vite Regolazione Minimo Carb.	Carb Idle Adjuster Screw	Vis de Réglage Ralenti Carburateur	Leerlaufgemischregulierschraube	Tornillo Regulación Rég. Mínimo Carb.
13	3404199 000		Tappo Scarico Allog. Galleg gigante Carb.	Carb Float Hsng Drain Plug	Bouchon deVidange Logement Flotteur Carburateur	Ablassschraube am Vergaserschwimmersitz	Tapón Descarga Aloj. Flotador Carb.
14	3404200 000		Anello Or Carb.	Carb O-ring	Joint torique Carburateur	O-Ring Vergaser	Anillo Or Carb.
15	3404201 000		Rondella Carb.	Carb Washer	Rondelle Carburateur	Unterlegscheibe Vergaser	Arandela Carb.
16	3404272 100		Vite regolazione aria minimo	Idle adjuster screw	Vis regl. air min.	Lurt regulierschraube min.	Tornillo regulación aire min.
17	3404203 000		Molla Per Regolazione Aria Carb.	Carb Air Adjuster Spring	Ressort Pour Réglage Air Carburateur	Feder für Luftregulierung Vergaser	Muelle Para Regulación Aire Carb.
18	3404204 000		Guarnizione Camera Galleg. Carb.	Carb Float Chamber Seal	Joint Chambre Flotteur Carburateur	Dichtung f. Schwimmerkammer Verg.	Junta Cámara Flotador Carb.
19	3404273 100		Sede spillo	Needle seat	Siège de l'aiguille	Nadelsitz	Asiento del obturador
20	3404274 100		Getto minimo 15	Starter jet 15	Gicleur starter 15	Starterdüse 15	Surtidor starter 15
21	3404275 100		Sede spillo	Needle seat	Siège de l'aiguille	Nadelsitz	Asiento del obturador
22	1642033 000		Getto massimo 92,5	Main jet 92,5	Gicleur maxi 92,5	Hauptdüse 92,5	Surtidor máximo 92,5
23	3404209 000		Anello Or Carb.	Carb O-ring	Joint torique Carburateur	O-Ring Vergaser	Anillo Or Carb.
24	3404210 000		Galleggainte Carb.	Carb Float	Flotteur Carburateur	Vergaserschwimmer	Flotador Carb.
25	3404276 100		Kit Valvola Spillo Carb.	Carb Needle Valve Kit	Kit Soupape Pointeau Carbuteur	Kit Vergasernadelventil	Kit Válvula Inyector Carb.
26	3404277 100		Vite kit Valvola Spillo	Carb Needle Valve Screw	Vis kit Soupape Pointeau	Schraube Kit Nadelventil	Tornillo Kit Válvula Inyector
27	3404212 000		Perno Per Galleggianta Carb.	Carb Float Pin	Axe pour Flotteur Carburateur	Stift für Vergaserschwimmer	Perno Para Flotador Carb.
28	3404278 100		Tubo scarico	Exh.pipe	Tuyau echapp.	Krummer	Tubo de escape
29	3404279 100		Tubo	Tube	Tuyau	Schlauch	Tubo
30	3404280 100		Vite	Screw	Vis	Schraube	Tornillo
31	3404219 000		Anello Or Carb.	Carb O-ring	Joint torique Carburateur	O-Ring Vergaser	Anillo Or Carb.
32	3404281 100		Getto massimo 125	Main jet 125	Gicleur maxi 125	Hauptdüse 125	Surtidor máximo 125
33	3404282 100		Rondella getto massimo	Main jet washer	Rondelle gicleur maxi	U.Scheibe Hauptdüse	Arandela surtidor máximo
34	3404266 100		Terminale temointerruttore	Termal switch terminal	Embout thermo- régulateur	Kabelschuh Umschalter	Terminal interruptor térmico
35	3404268 100		Termointerruttore	Termal switch	Thermo- régulateur	Umschalter	Interruptor térmico
36	3404267 100		Rondella	Washer	Rondelle	U.Scheibe	Arandela
37	3404285 100		Raccordo a T	T joint.p.	Raccord a T	T Stutzen	Racor a T
38	3404286 100		Tubo	Tube	Tuyau	Schlauch	Tubo
39	3404287 100		Tubo	Tube	Tuyau	Schlauch	Tubo

Tav.8

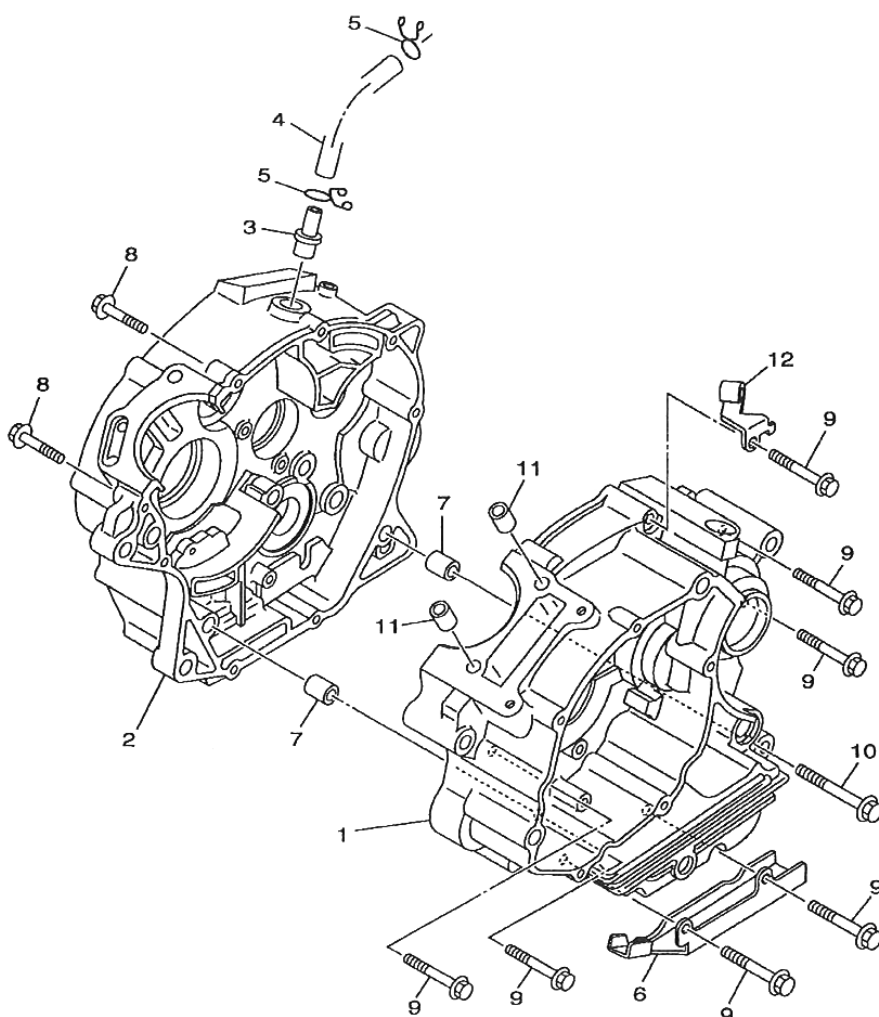

Pos Loc Pos Ps Pos	Numero Number Numéro Número Nummer	Nota Note Note Nota Anm.	Descrizione	Description	Désignation	Beschreibung	Descripción
1	3404227 100		Carter (1)	Crankcase (1)	Carter (1)	Kurbelwellengehäuse (1)	Cárter (1)
2	3404227 200		Carter (2)	Crankcase (2)	Carter (2)	Kurbelwellengehäuse (2)	Cárter (2)
3	3404139 100		Raccordo Per Tubo Ricircolo Aria	Air Recirculation Hose Union	Raccord Pour Tubulure Recirculation Air	Anschluss für Luftrückführungsschlauch	Empalme Para Tubo Recirculación Aire
4	3404138 100		Tubo Ricircolo Aria	Air Recirculation Hose	Tubulure Recirculation Air	Luftrückführungsschlauch	Tubo Recirculación Aire
5	3404150 100		Anello Ce	CE Ring	Bague Ce	CE Ring	Anillo Ce
6	3404231 100		Protezione Cavo Motorino Avv.	Starter Motor Cable Guard	Protection Câble Démarreur	Schutz f. Anlassmotorkabel	Protección Cable Motor Arr.
7	3404232 100		Grano Di Riferimento Cilindro	Cylinder Reference Dowel	Pion de Repère Cylindre	Zentrierstift für Zylinder	Espiga de Referencia Cilindro
8	3404145 100		Bullone Flangiato	Head Flanged bolt	Boulon Bridé Culasse	Bundbolzen für Zylinderkopf	Bulón con Brida Culata
9	3404146 100		Bullone Flangiato	Head Flanged bolt	Boulon Bridé Culasse	Bundbolzen für Zylinderkopf	Bulón con Brida Culata
10	3404147 100		Bullone Flangiato	Head Flanged bolt	Boulon Bridé Culasse	Bundbolzen für Zylinderkopf	Bulón con Brida Culata
11	3404232 100		Grano Di Riferimento Cilindro	Cylinder Reference Dowel	Pion de Repère Cylindre	Zentrierstift für Zylinder	Espiga de Referencia Cilindro
12	3404143 100		Piastrina Passaggio Tubo Frizione	Clutch Hose Guide Plate	Plaquette Passage Durite Embrayage	Durchführplättchen f. Kupplungsleitung	Plaqueta Pasaje Tubo Embrague



Beta
the play bike

Tav.9

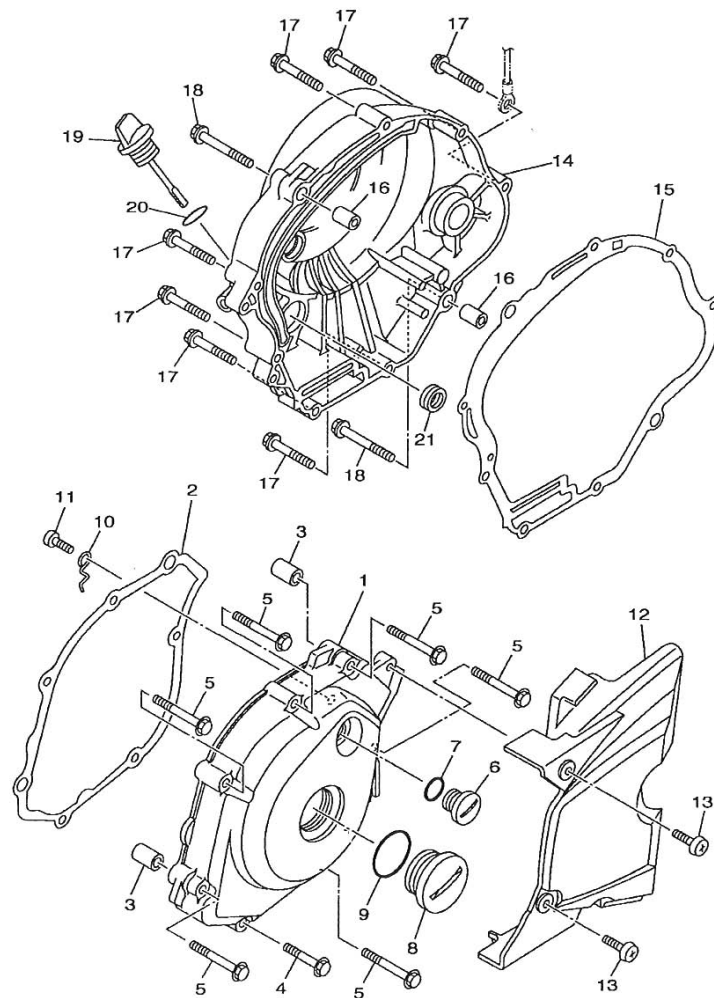

Pos Loc Pos Ps Pos	Numero Number Número Nummer	Nota Note Nota Anm.	Descrizione	Description	Désignation	Beschreibung	Descripción
1	3404141 100		Coperchio Est Carter Motore	Crankcase Ext Cover	Couvercle Ext Carter Moteur	Äußerer Motorgehäuse- Dichtung/äußeren Motorgehäusedeckel	Tapa Ext Carter Motor
2	3404144 100		Guarnizione Coperchio Est Motore	Crankcase Ext Cover Seal	Joint Couvercle Ext Moteur	Dichtung/äußeren Motorgehäusedeckel	Junta Tapa Ext Motor
3	3404232 100		Grano Di Riferimento Cilindro	Cylinder Reference Dowel	Pion de Repère Cylindre	Zentrierstift für Zylinder	Espiga de Referencia Cilindro
4	3404156 100		Bullone Flangiato	Head Flanged bolt	Boulon Bridé Classe	Bundbolzen für Zylinderkopf	Bulón con Brida Culata
5	3404157 100		Bullone Flangiato	Head Flanged bolt	Boulon Bridé Classe	Bundbolzen für Zylinderkopf	Bulón con Brida Culata
6	3404148 100		Tappo Coperchio Est Carter Motore	Crankcase Ext Cover Plug	Bouchon Couvercle Ext	Verschluss am äußeren Motorgehäusedeckel	Tapón Tapa Ext Carter Motor
7	3404153 100		Anello Or	Ring	Bague d'étanchéité	O-Ring	Anillo OR
8	3404149 100		Tappo Coperchio Est Carter Motore	Crankcase Ext Cover Plug	Bouchon Couvercle Ext	Verschluss am äußeren Motorgehäusedeckel	Tapón Tapa Ext Carter Motor
9	3404155 100		Anello Or	Ring	Bague d'étanchéité	O-Ring	Anillo OR
10	3404140 100		Piastrina	Plate	Plaque	Plättchen	Placa
11	3404158 100		Vite Testa Piana	Flat Head Screw	Vis à Tête Plate	Flachkopfschraube	Tornillo Cabeza Plana
12	1267928 000		Carter Catena	Chain guard	Carter chaîne	Kettengehäuse	Carter cadena
13	3404159 100		Vite Incavo A Croce	Phillips Screw	Vis Creuse Cruciforme	Kreuzinbusschraube	Tornillo Hueco en Cruz
14	3404142 100		Coperchio Int Carter Motore	Crankcase Int Cover	Couvercle Int Carter Moteur	Innerer Motorgehäuse-deckel	Tapa Int Carter Motor
15	3404061 100		Guarnizione Carter Motore	Crankcase Gasket	Joint Carter Moteur 4t	Motorgehäusedichtung	Junta Carter Motor
16	3404232 100		Grano Di Riferimento Cilindro	Cylinder Reference Dowel	Pion de Repère Cylindre	Zentrierstift für Zylinder	Espiga de Referencia Cilindro
17	3404156 100		Bullone Flangiato	Head Flanged bolt	Boulon Bridé Classe	Bundbolzen für Zylinderkopf	Bulón con Brida Culata
18	3404146 100		Bullone Flangiato	Head Flanged bolt	Boulon Bridé Classe	Bundbolzen für Zylinderkopf	Bulón con Brida Culata
19	3404137 100		Tappo Con Asta Livello Olio	Plug w/Oil Dipstick	Bouchon Avec Jauge Niveau Huile	Ölmesstabschraube	Tapón con Varilla Nivel Aceite
20	3404154 100		Anello Or	Ring	Bague d'étanchéité	O-Ring	Anillo OR
21	3404152 100		Anello Paraolio	Oil seal	Joint d'étanchéité	Ölschutzring	Retén de aceite
22	1332366 600		Decalco coperchio volano	Flywheel cover transfer	Décalcomanie pour varter volant	Abziehbild Schwungraddeckel	Calcomania tapa volante

Tav.10

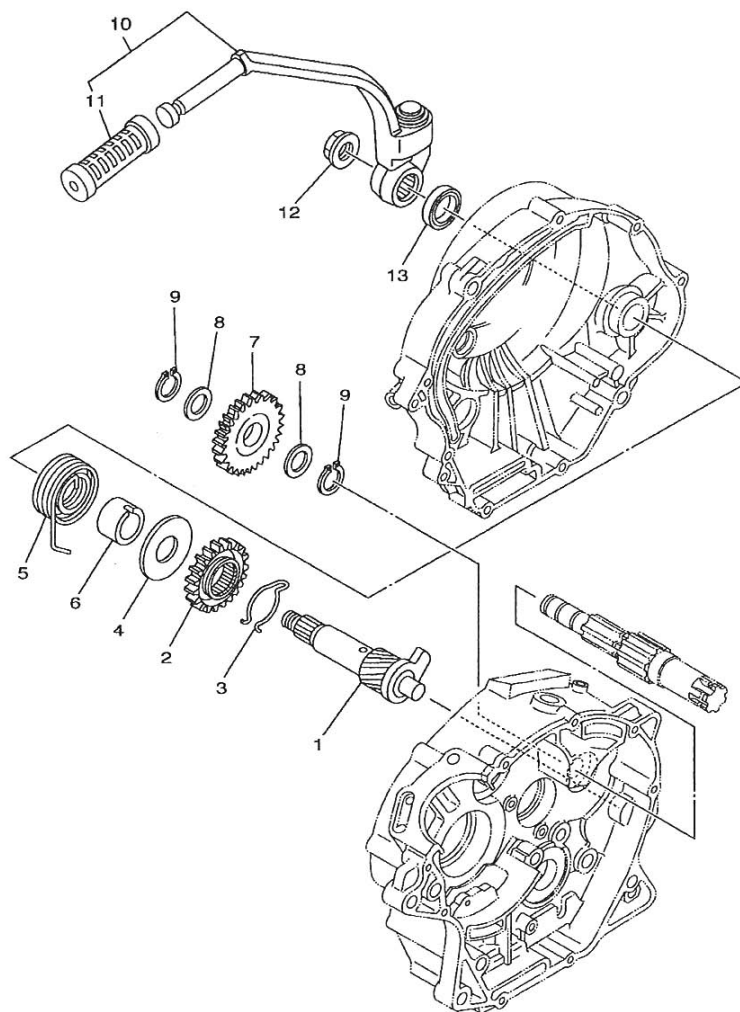

Pos Loc Pos Ps Pos	Numero Number Numéro Número Numer	Nota Note Note Nota Anm.	Descrizione	Description	Désignation	Beschreibung	Descripció
1	3404063 100		Albero Kick-Starter Compl.	Compl. Kick Starter Shaft	Arbre Kick-Starter Complet	Komplette Kick-Starterwelle	Árbol Kick-Starter Compl.
2	3404062 100		Ingranaggio Albero Kick- Starter	Compl. Kick Starter ShaftGear	Pignon Arbre Kick-Starter	Zahnrad Kick-Starterwelle	Engranaje Árbol Kick-Starter
3	3404069 100		Molletta Fissaggio Messa In Moto	Starter Clip	Agrafe de Fixation Mise en Marche	Feder f. Anwurfbefestigung	enacilla Fijación Puesta en Marcha
4	3404068 100		Rondella Kick-Starter	Kick-Starter Washer	Rondelle Kick-Starter	Unterlegscheibe Kick-Starter	Arandela Kick-Starter
5	3404070 100		Molla Ritorno Albero Kick-Starter	Kick Starter Shaft Return Spring	Ressort Retour Arbre Kick- Starter	Rückzugfeder f. Kick-Starter-welle	Muelle Retorno Árbol Kick-Starter
6	3404066 100		Distanziale Kick-Starter	Kick-Starter Spacer	Entretoise Kick-Starter	Distanzstück Kick-Starter	Separador Kick-Starter
7	3404067 100		Ingranaggio Trasm. Kick- Starter	Kick Starter Drive Gear	Pignon Transmission Kick- Starter	Antriebsrad Kick-Starter	Engranaje Transm. Kick- Starter
8	3404247 100		Rondella	Washer	Rondelle	U.Scheibe	Arandela
9	3404073 100		Seeger	Circlip	Circlip	Seeger	Seeger
10	3404161 100		Leva Kick-Starter Completa	Compl. Kick Starter Lever	Levier Kick-Starter Complet	Kompletter Kick-Starterhebel	Leva Kick-Starter Completa
11	3404160 100		Gommino Leva Kick-Starter	Kick Starter Lever Seal	Plot caoutchouc Levier Kick-Starter	Gummielement f. Kick-Start-	Goma Leva Kick-Starter
12	3404085 100		Dado Fissaggio Leva Kick-Starter	Kick Starter Lever Rtnng Nut	Ecrou de Fixation Levier Kick-Starter	Klemmmutter f. Kick-Start-	Tuerca Fijación Leva Kick-
13	3404237 100		Anello In Gomma	Rubber Ring	Bague en Caoutchouc	Gummiring	Anillo de Goma



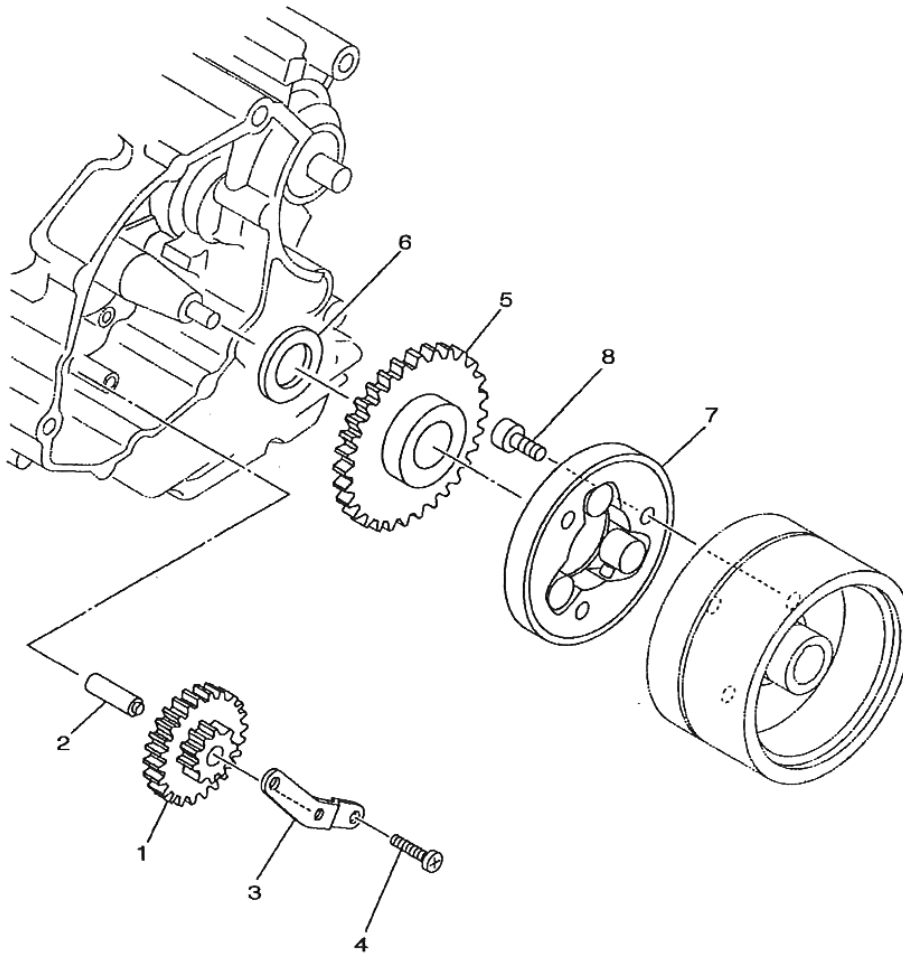

Pos Loc Pos Ps Pos	Numero Number Número Número	Nota Note Note Nota Anm.	Descrizione	Description	Désignation	Beschreibung	Descrìption
1	3404248 100		Ingranaggio Guidato Motorino Av	Starter Motor Driven Gear	Pignon Guidé Démarreur Electrique	Geführtes Anlasserzahnrad	Engranaje Guiado Motor Arranque
2	3404064 100		Alberino Ingranaggio Mot	Starter Motor Gear Shaft	Axe Pignon Démarreur Electrique	Anlasserzahnradwelle	Árbol Engranaje Motor Arranque
3	3404065 100		Piastrina Mot Avviamento	Starter Motor Plate	Plaque Démarreur Electrique	Plättchen f Anlassmotor	Plaqueta Motor Arranque
4	3404072 100		Vite Fissaggio Piastrina Mot Avviamento	Starter Motor Plate Rtnng Screw	Vis de Fixation Plaque Démarreur Electrique	Befestigungsschraube Plättchen Anlassmotor	Tornillo Fijación Plaqueta Motor Arranque
5	3404249 100		Ingranaggio Guida Motorino Av	Starter Motor Drive Gear	Pignon de Guidage Démarreur Electrique	Führungszahnrad Anlassmotor	Engranaje Guía Motor Arranque
6	3404002 100		Rondella Avviamento	Starter Washer	Rondelle Démarrage	Unterlegscheibe f Anlass	Arandela Arranque
7	3404000 100		Ruota Libera	Free wheel	Roue libre	Freilauf	Rueda libre

Tav.12

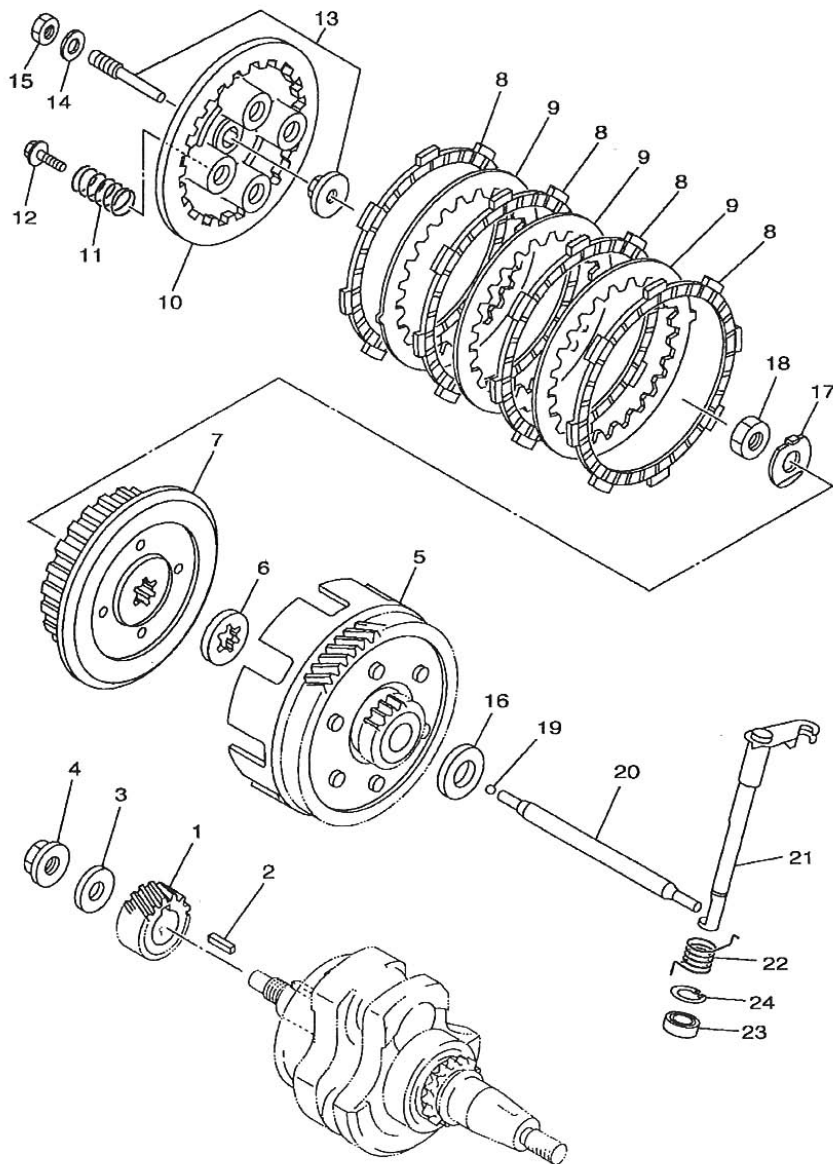

Tav.12

Pos Loc Pos Ps Pos	Numero Number Número Número Nummer	Nota Note Nota Nota Anm.	Descrizione	Description	Désignation	Beschreibung	Descripción
8 1	3404071 100 3404228 100		Bullone Ingranaggio Guida Trasmis. Primaria	Bolt Drive Gear, Main Drive	Boulon Pignon de Guidage Transmis sion Primaire	Bolzen Führungszahnrad	Tornillo Engranaje Guía Transmis.
2 3 4 5 6 7 8 9 10 11	3404089 100 3404086 100 3404085 100 3404230 100 3404076 100 3404080 100 3404077 100 3404074 100 3404078 100 3404229 100		Chiavetta Rondella Dado Fissaggio Leva Kick-Start Frizione Innesto Asta Corpo Frizione Mozzo Interno Frizione Disco Frizione Disco Frizione Intermedio Coperchio A Pressione Frizione Molla Compressione Cop.Friz.	Key Washer Kick Starter Lever Rtnng Nut Clutch Clutch Housing Rod Coupling Clutch Internal Hub Clutch disk Intermediate Clutch Plate Clutch Pressure Plate Clutch Pressure Plate Spring	Clavette Rondelle Ecrou de Fixation Levier Kick-Start Embrayage Crabot Tige Corps Embrayage Moyeu Interne Embrayage Disque embr. Disque Embrayage Intermédiaire Couvercle A Pression Embrayage Ressort Compression Couvercle Embrayage	Keil U.Scheibe Klemmmutter f. Kick-Start- Kupplung Stabeinkupplung Kupplungskörper Innere Kupplungsabe Kupplungs-scheib Mittlere Kupplungsscheibe Kupplungsdruckscheibe Andrückfeder Kup-	Chaveta Arandela Tuerca Fijación Leva Kick- Embrague Acople Varilla Cuerpo Embrague Cubo Interior Embrague Disco de embrague Disco Embrague Intermedio Tapa a Presión Embrague Muelle Compresión Tapa
12 13 fij	3404084 100 3404075 100		Bullone Flangiato Frizione Dado+Perno Speciale di Fissaggio	Clutch Flanged Bolt Clutch plate+pin special ring nut	Boulon Bridé Embrayage Ecrou+axe spécial de fixation	Bundbolzen f. Kupplung Spez.mutter+kupplungsführungsstift	Bulón con Brida Embrague Tuerca+perno guía especial de
14 15 16 17 18 19 20 21 22 23 24	3404254 100 3404250 100 3404081 100 3404088 100 3404251 100 3404091 100 3404082 100 3404083 100 3404162 100 3404090 100 3404092 100		Rondella Dado Rondella Di Supporto Frizione Rondella Di Fissaggio Frizione Dado Sfera Asta Spingidisco Frizione Leva A Pressione Comado Frizione Molla Ritorno Leva A Pres. Cam. Friz. Anello Paraolio Seeger	Washer Nut Clutch Thrust Washer Clutch Rtnng Washer Nut Ball Clutch Pushrod Clutch Push Lever Clutch Push Lever Return Spring Oil seal Circlip	Rondelle Ecrou Rondelle de Support Rondelle de Fixation Ecrou Bille Tige Presse-disque Embrayage Levier A Pression Commande Ressort de Retour Levier A Joint d'étanchéité Circlip	U.Scheibe Mutter Unterlegscheibe f. Kup- Unterlegscheibe für Kupplungs- Mutter Kugel Kupplungsscheibendruckstab Druckhebel für Kupplungs- Rückzugfeder für Kup- Ölschutzring Seeger	Arandela Tuerca Arandela de Soporte Arandela de Fijación Tuerca Bola Varilla Empuja-disco Embrague Leva a Presión Mando Muelle Retorno Leva a Pres. Retén de aceite Seeger

Tav.13

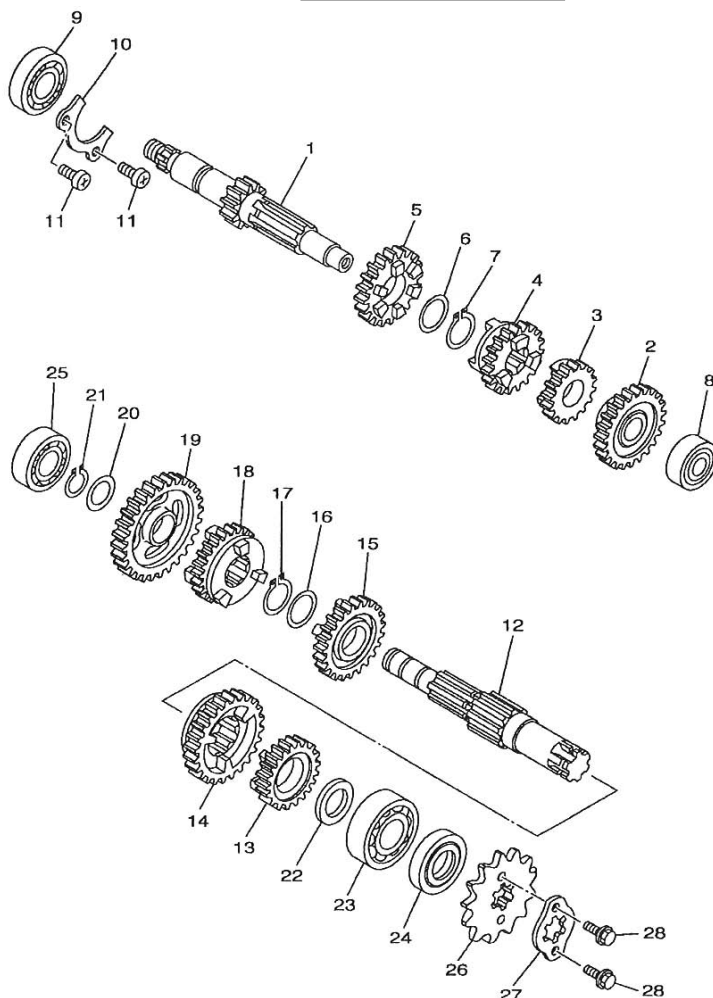

Pos Loc Ps Pos	Numero Number Número Número	Nota Note Nota Anm.	Descrizione	Description	Désignation	Beschreibung	Descripción
1	3404166 100		Albero Trasmissione Primaria	Main Drive Shaft	Arbre Transmission Primaire	Primäraantriebswelle	Árbol Transmisión Primaria
2	3404097 100		Ingranaggio 5° AlberoPrimario	5th Gear, Main Shaft	Pignon 5e Arbre Primaire	5. Zahnrad Primärwelle	Engranaje 5° Árbol Primario
3	3404093 100		Ingranaggio 2° AlberoPrimario	2nd Gear, Main Shaft	Pignon 2e Arbre Primaire	2. Zahnrad Primärwelle	Engranaje 2° Árbol Primario
4	3404094 100		Ingranaggio 3° AlberoPrimario	3rd Gear, Main Shaft	Pignon 3e Arbre Primaire	3. Zahnrad Primärwelle	Engranaje 3° Árbol Primario
5	3404163 100		Ingranaggio 4° AlberoPrimario	4th Gear, Main Shaft	Pignon 4e Arbre Primaire	4. Zahnrad Primärwelle	Engranaje 4° Árbol Primario
6	3404101 100		Rondella	Washer	Rondelle	U.Scheibe	Arandela
7	3404171 100		Seeger	Circlip	Circlip	Seeger	Seeger
8	3404167 100		Cuscinetto	Bearing	Roulement	Lager	Cojinete
9	3404169 100		Cuscinetto	Bearing	Roulement	Lager	Cojinete
10	3404100 100		Piastrina Trasmissione	Transmission Plate	Plaquette Transmission	Plättchen Antrieb	Plaqueta Transmisión
11	3404105 100		Vite Fissaggio Piastrina Trasmissione	Transmission Plate Rtnng Screw	Vis de Fixation Plaquette Transmiss.	Befestigungsschraube Plät then Antrieb	Tornillo Fijación Plaqueta Transm.
12	3404165 100		Albero Trasmissione Secondaria	Final Drive Shaft	Arbre Transmission Secondaire	Sekundärantriebswelle	Árbol Transmisión Secundaria
13	3404098 100		Ingranaggio 5° Albero Secondario	5th Gear, Lay Shaft	Pignon 5e Arbre Secondaire	5. Zahnrad Sekundärwelle	Engranaje 5° Árbol Secundario
14	3404099 100		Ingranaggio 2° Albero Secondario	2nd Gear, Lay Shaft	Pignon 2e Arbre Secondaire	2. Zahnrad Sekundärwelle	Engranaje 2° Árbol Secundario
15	3404164 100		Ingranaggio 3° Albero Secondario	3rd Gear, Lay Shaft	Pignon 3e Arbre Secondaire	3. Zahnrad Sekundärwelle	Engranaje 3° Árbol Secundario
16	3404101 100		Rondella	Washer	Rondelle	U.Scheibe	Arandela
17	3404171 100		Seeger	Circlip	Circlip	Seeger	Seeger
18	3404096 100		Ingranaggio 4° Albero Secondario	4th Gear, Lay Shaft	Pignon 4e Arbre Secondaire	4. Zahnrad Sekundärwelle	Engranaje 4° Árbol Secundario
19	3404095 100		Ingranaggio 1° Albero Secondario	1st Gear, Lay Shaft	Pignon 1er Arbre Secondaire	1. Zahnrad Sekundärwelle	Engranaje 1° Árbol Secundario
20	3404252 100		Rondella	Washer	Rondelle	U.Scheibe	Arandela
21	3404073 100		Seeger	Circlip	Circlip	Seeger	Seeger
22	3404102 100		Rondella	Washer	Rondelle	U.Scheibe	Arandela
23	3404170 100		Cuscinetto	Bearing	Roulement	Lager	Cojinete
24	3404103 100		Anello Paraolio	Oil seal	Joint d'étanchéité	Ölschutzring	Retén de aceite
25	3404168 000		Cuscinetto	Bearing	Roulement	Lager	Cojinete
26	3404104 100		Pignone Z.14	Sprocket Z.14	Pignon Z.14	Ritzel Z.14	Piñón Z.14
27	3404253 100		Piastrina Pignone	Sprocket Plate	Plaquette Pignon	Ritzelplättchen	laqueta Piñón
28	3404239 100		Vite Fissaggio Piastra Pignone	Sprocket Plate Rtnng Screw	Vis de Fixation Plaquette	Befestigungsschraube Ritzel- plättchen	Tornillo Fijación Placa Piñón



Tav.14

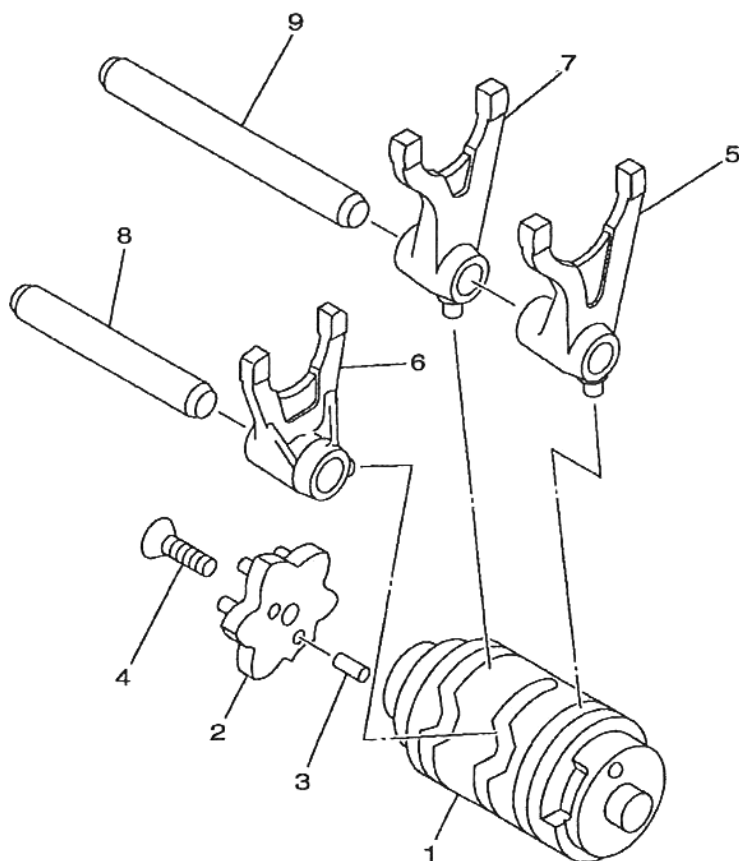

Pos Loc Pos Ps Pos	Numero Number Número Número	Nota Note Nota Anm.	Descrizione	Description	Désignation	Beschreibung	Descripción
1	3404175 100		Camma	Cam	Came	Nocke	Excéntrica
2	3404107 100		Camma Arresto Marce	Gear Stopper Cam	Came Butée Vitesses	Gangsperrnocken	Leva Parada Marchas
3	3404113 100		Spina	Pin	Goupille	Stift	Pasador
4	3404176 100		Vite Fissaggio Camma Arresto Marce	Gear Stopper Cam Rtnng Screw	Vis de Fixation Came Butée Vitesses	Befestigungsschraube f.	Tornillo Fijación Leva Parada
5	3404108 100		Forchetta Selezione Sel. 1	Selector Fork Sel. 1	Fourchette Sélection Sél. 1	Schaltgabel 1.Gang	Horquilla Selección Sel. 1
6	3404109 100		Forchetta Selezione Sel. 2	Selector Fork Sel. 2	Fourchette Sélection Sél. 2	Schaltgabel 2.Gang	Horquilla Selección Sel. 2
7	3404110 100		Forchetta Selezione Sel. 3	Selector Fork Sel. 3	Fourchette Sélection Sél. 3	Schaltgabel 3.Gang	Horquilla Selección Sel. 3
8	3404111 100		Albero Forchetta Sel. 3	Selector Fork Shaft Sel. 3	Axe Fourchette Sél. 3	Gabelwelle 3. Gang	Árbol Horquilla Sel. 3
9	3404112 100		Albero Forchetta Sel. 1-2	Selector Fork Shaft Sel. 1-2	Axe Fourchette Sél. 1-2	Gabelwelle 1.-2. Gang	Árbol Horquilla Sel. 1-2



Tav.15

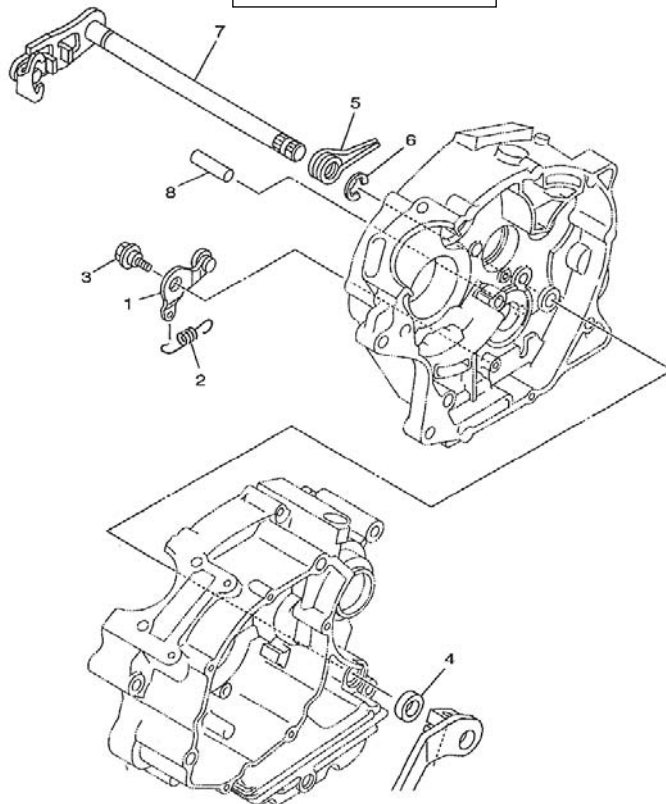

Pos Loc Pos Ps Pos	Numero Number Número Número	Nota Note Nota Anm.	Descrizione	Description	Désignation	Beschreibung	Descripción
1	3404172 100		Piastrina Fissaggio Leva Com.Cambio	Gear Lever Rtnng Plate	Plaquette Fixation Levier Sélecteur de Vitesse	Befestigungsplättchen Schaltsteuerhebel	Plaqueta Fijación Leva Mando Cambio
2	3404174 100		Molla Piastrina Fiss. Leva Com.Cambio	Spring gear Lever Rtnng Plate	Ressort plaquette Fix. Levier Sél.r de Vitesse	Befestigungsplättchenfeder Schaltsteuerhebel	Muelle plaqueta Fij. Leva Mando Cambio
3	3404241 100		Bullone Speciale	Special bolt	Boulon spéciale	Spezialschraube	Tornillo especial
4	3404178 100		Paraolio Leva Comando Cambio	Gear Lever Oil Seal	Joint d'huile Levier Sélect-eur de Vitesse	Ölabdichtung f. Schaltsteuer-hebel	Retén Aceite Leva Mando Cambio
5	3404177 100		Molla Ritorno Leva Com. Cambio	Gear Lever Return Spring	Ressort de Retour Levier Sélecteur de Vitesse	Rückzugfeder f. Schalts-steuerhebel	Muelle Retorno Leva Mando Cambio
6	3404242 100		Seeger	Circlip	Circlip	Seeger	Seeger
7	3404173 100		Albero Comando Cambio	Gearshift shaft	Arbre de vitesse	Schaltwelle	Eje mando cambio
8	3404179 100		Perno Leva Com.Cambio	Gear Lever Pin	Axe Levier Sélecteur de Vitesse	Stift f. Schaltsteuerhebel	Perno Leva Mando Cambio



Tav.16

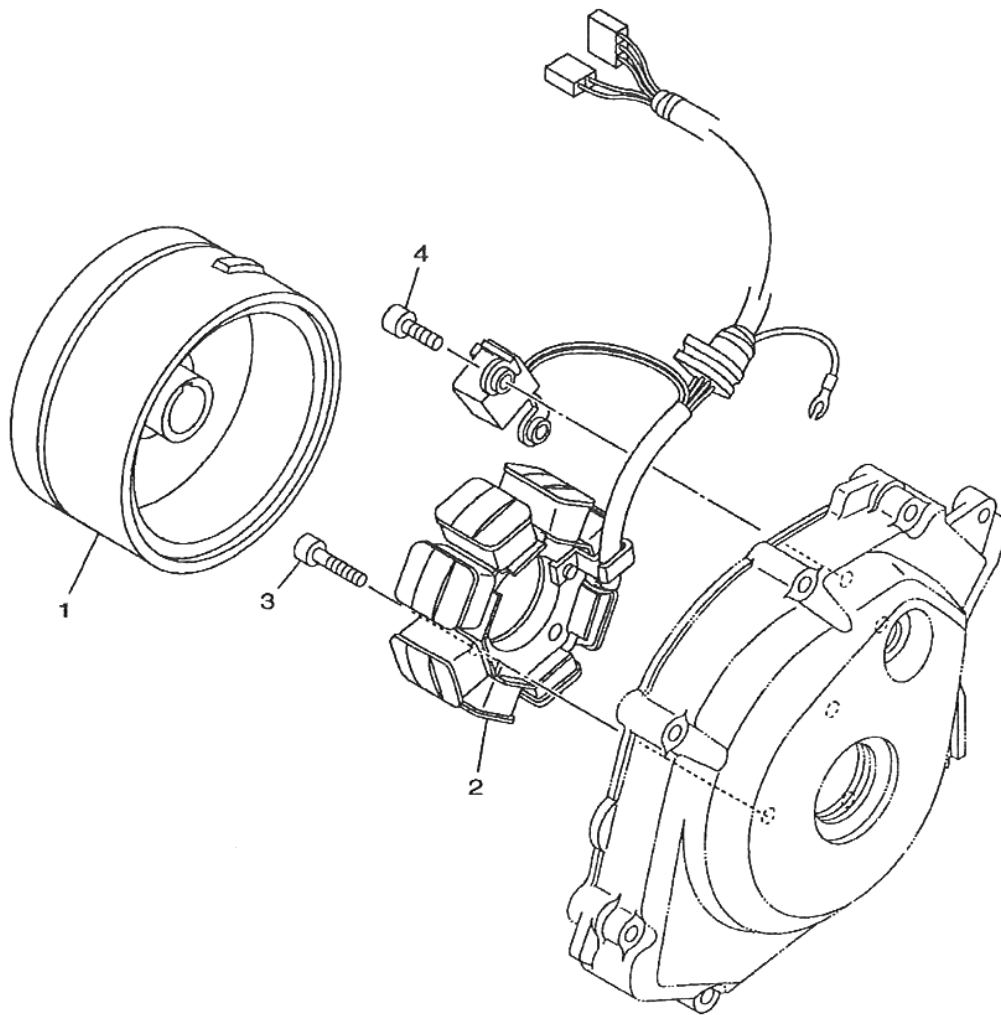

Pos Loc Pos Ps Pos	Numero Number Número Número	Nota Note Note Nota Anm.	Descrizione	Description	Désignation	Beschreibung	Descrìpçìon
1	3404183 100		Rotore	Rotor	Rotor	Rotor	Rotor
2	3404132 100		Statore Completo	Backplate, assy.	Stator, assy.	Ankerplatte kpl.	Estator completo
3	3404106 100		Bullone	Bolt	Boulon	Bolzen	Tornillo
4	3404182 100		Bullone C/Esagono Incassato	Hex Socket Head Bolt	Boulon Six-pans Creux	Inbusbolzen	Bulón con Hexágono Encas-trado

Tav.17

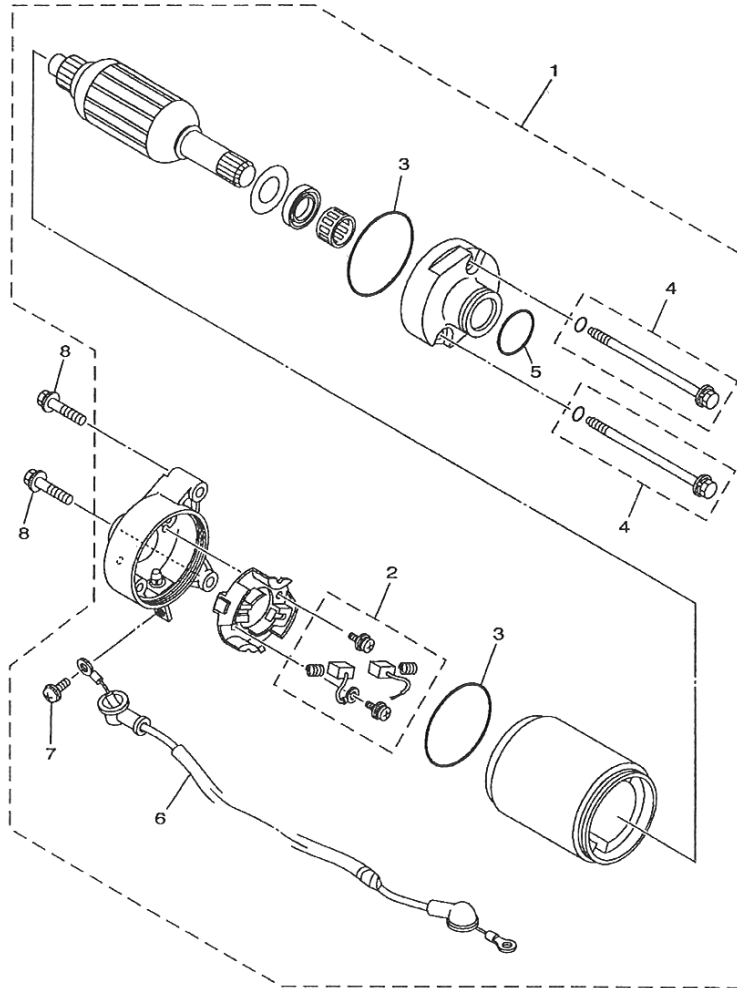

Pos Loc Pos Ps Pos	Numero Number Numéro Número Nummer	Nota Note Note Nota Anm.	Descrizione	Description	Désignation	Beschreibung	Descripción
1	3404001 100		Motorino Avviamento	Starter motor	Moteur du démarreur	Startermotor	Motor de arranque
2	3404114 100		Kit Puntine Motorino Avviamento	Points Kit, Starter Motor	Kit Eléments de contact Démarreur Electrique	Kit Zündstifte f Anlassmotor	Kit puntas de encendido
3	3404119 100		Anello Or 50m Motorino Avviamento	50m O-ring, Starter Motor	Joint Torique 50m Démarreur Electrique	O-Ring 50m Anlassmotor	Anillo Or 50m Motor
4	3404115 100		Bullone Motorino Avviamento	Starter Motor Bolt	Boulon Démarreur Electrique	Bolzen f Anlassmotor	Bulón Motor Arranque
5	3404118 100		Anello Or Motorino Avviamento	Starter Motor O-ring	Joint Torique Démarreur Electrique	O-Ring f Anlassmotor	Anillo Or Motor Arranque
6	1801608 000		Impianto elettr massa mot avviamento	Starter Mot Ground Wiring Harness	Circuit Electrique Masse Démarreur Electrique	Elektr Anlage Anlassmotormasse	Sistema Electr Masa Motor Arranque
7	3404121 100		Vite Fissag Cavo Massa Int Av	Starter Int Ground Cable Rtnng Screw	Vis de Fixation Câble Masse Bouton de Démarrage	Befestsschraube int Massekabel Anlasserschalter	Tornillo Fijación Cable Masa Int Arr
9	3404120 100		Bullone Flangiato Fis Mot Avviamento	Starter Motor Flanged Rtnng Bolt	Boulon Bridé Fixation Démarreur Electrique	Bundbolzen f Befest Anlassmotor	Bulón con Brida Fij Motor Arranque



Tav.18

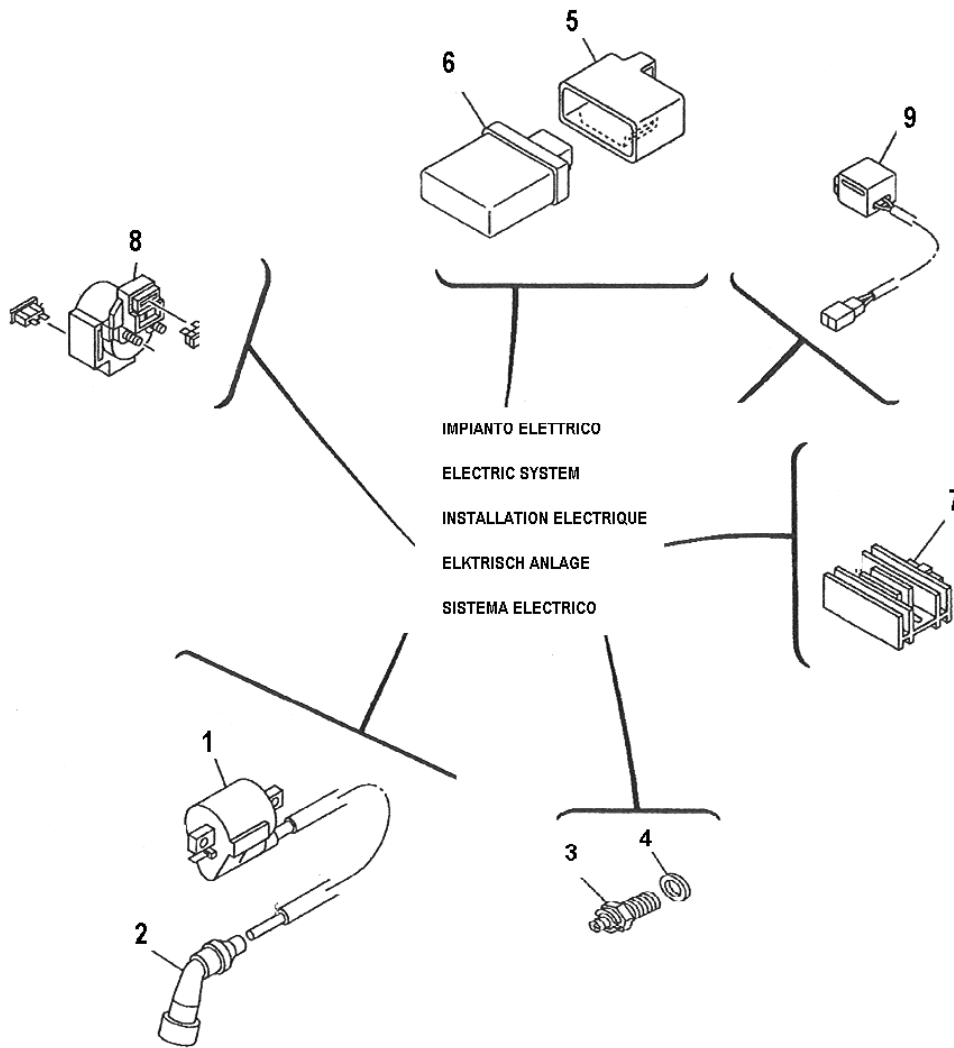

Pos Loc Pos Ps Pos	Numero Number Numéro Número Nummer	Nota Note Note Nota Anm.	Descrizione	Description	Désignation	Beschreibung	Descripción
1	1120643 800		Bobina	Coil	Bobine	Spule	Bobina
2	2713556 000		Cappuccio candela	Spark plug cap	Capuchon/couvercle bougie	Zündkerzenkappe	Capuchón de la bujía
3	3404180 000		Interruttore Folle	Neutral switch	Int, poinr mort	Leerlaufschalter	Int. punto muerto
4	3404181 000		Guarnizione Interruttore Folle	Neutral Switch Seal	Joint Contacteur Point Mort	Dichtung f. Leerlaufschalter	Junta Interruptor Desem-
5	1241854 000		Centralina elettronica	Electronic control unit (ECU)	Centrale	Elektronisches Steuergerät	Centralita electrónica
6	2897897 000		Guscio Centralina	ECU Shell	Enceinte Boîtier Electronique	Steuergerätverschaltung	Carcasa Central
7	2728104 000		Regolatore	Regulator	Régulateur	Regler	Regulador
8	2728474 000		Relè avviamento	Relais de demarrage	Starter relay	Anlassrelais	Relé de arranque
9	2911957 000		Sensore Temperatura aria	Air temperature sensor	Capteur température air	Lufttemperatursensor	Sensor temperatura aire

Tav.19

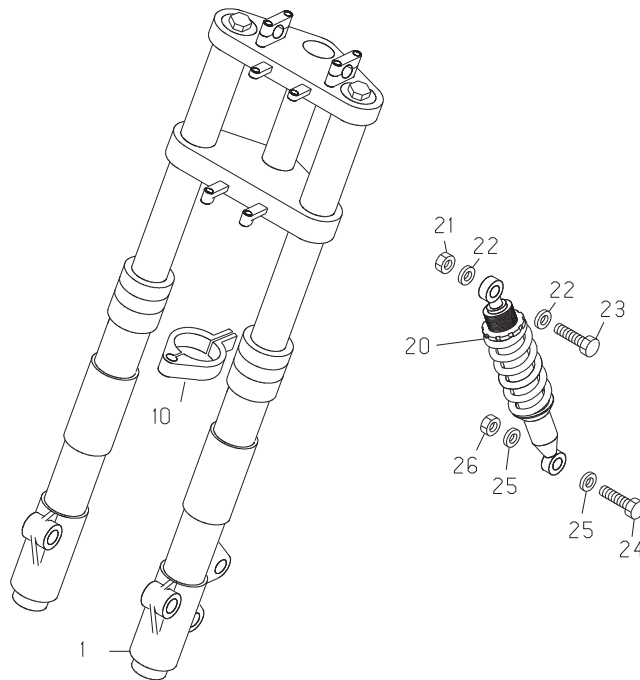

Pos Loc Pos Ps Pos	Numero Number Numéro Número Nummer	Nota Note Note Nota Anm.	Descrizione	Description	Désignation	Beschreibung	Descripció
1	1508136 000		Forcella	Fork	Fourche	Gabel	Horquilla
10	1514611 052		Fascetta tubo freno	Clamp	Collier tube frein disque	Schelle F. Bremsschlauch	Brida fijacion tubo freno
20	1004019 000		Ammortizzatore	Damper	Amortisseur	Stoßdämpfer	Amortiguador
21	1319010 000		Dado autoblocc. Basso M10	Nut M10	Ecrou M10	Mutter M10	Tuerca M10
22	2754000 000		Rondella 10x21x2	Washer 10x21x2	Rondelle 10x21x2	Scheibe 10x21x2	Arandela 10x21x2
23	1163000 000		Bullone 10x50	Bolt 10x50	Boulon 10x50	Bolzen 10x50	Tornillo 10.50
24	1163000 000		Bullone 10x50	Bolt 10x50	Boulon 10x50	Bolzen 10x50	Tornillo 10.50
25	2754000 000		Rondella 10x21x2	Washer 10x21x2	Rondelle 10x21x2	Scheibe 10x21x2	Arandela 10x21x2
26	1319010 000		Dado autoblocc. Basso M10	Nut M10	Ecrou M10	Mutter M10	Tuerca M10



Tav.19A

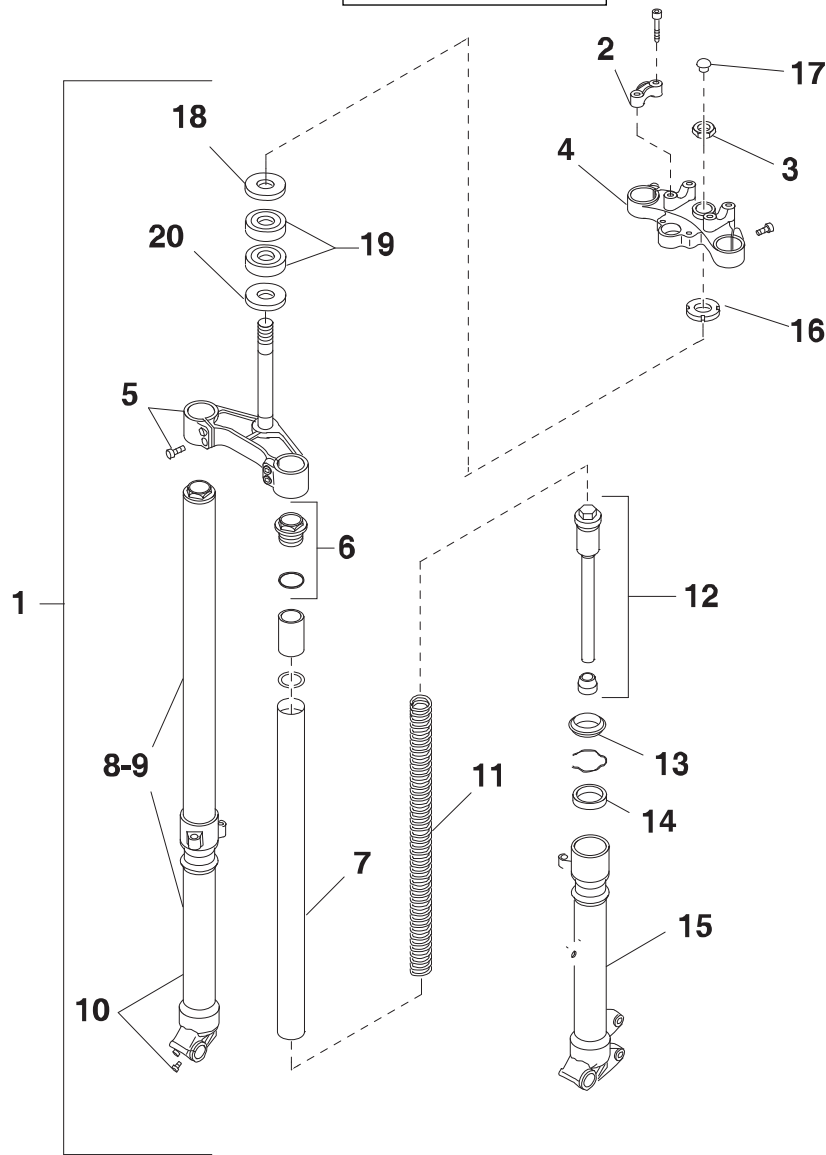

Pos Loc Pos Ps Pos	Numero Number Número Nummer	Nota Note Note Nota Anm.	Descrizione	Description	Désignation	Beschreibung	Descrìption
1	1508136 000		Forcella	Fork	Fourche	Gabel	Horquilla
2	1208271 057		Cavalotto fissaggio manubrio	U-bolt for handlebar fastening	Cavalier pour fixage guidon	Bügelbolzen für Lenkstangenbefestigung	Brida fij. manillar
3	1330960 000		Dado canotto	Head tube nut	Ecrou colonne	Lenkrohrmutter	Tuerca
4	2950165 057		Testa di sterzo	Steering head	Tête de direction	Gabelkopf	Tija superior
5	1209685 057		Crociera c/cannotto	Cross with tube	Croisillon	Gelenkkreuz mit Rohr	Cruceta con manguito
6	2901874 000		Tappo con anello	Plug with ring	Bouchon avec bague	Verschluss mit ring	Tapón con anillo
7	2940445 000		Tubo completo ambidx	LH-RH tube assy.	Tube D./G. complet	Rohr komplett r./l.	Tubo completo der./izq.
8	1600842 000		Gamba dx. compl.	R.H. fork leg assy	Fourche complete D.	Telegabel Kpl. R.	Horquilla derecha compl.
9	1600852 000		Gamba sx. compl.	L.H. fork leg assy	Fourche compl. G.	Telegabel, Kpl. L.	Horquill izrada. compl.
10	1618383 000		Gamba dx	RH leg	Tube D.	Rechte Beineinheit	Pata derecha
11	2252512 000		Molla forcella	Fork spring	Ressort fourche	Gabelfeder	Muelle horquilla
12	1232607 000		Cartuccia meccanica	Mechanical cartridge	Cartouche amort.	Mechanische Hülle	Cartucho mecanico
13	1041432 000		Anello parapolvere	Dust cover	Disque pare-poussière	Staubdeckel	Disco gurdapolvo
14	1041282 000		Anello di tenuta	Oil seal	Joint spie	Dichtring	Retén de aceite
15	1618658 000		Gamba sx	LH leg	Tube G.	Linke Beineinheit	Pata izquierda
16	1620620 000		Ghiera registro forcella	Fork adjusting ring nut	Douille reglage fourche	Einstellung gabel	Casquillo regul. horquilla
17	2901922 000		Protezione	Protection	Protection	Schutzstück	Protección
18	2598781 000		Protezione cuscinetto sterzo	Ball-bearing protection	Protection roulement guidon	Abdeckung Lenkerslager	Proteccion cojinete manillar
19	1299300 000		Cuscinetto conico 25x47x15	Conical bearing 25x47x15	Roulement conique 25x47x15	Lager 25x47x15	Cojinete conico 25.47.15
20	2598751 000		Protezione cuscinetto sterzo	Ball-bearing protection	Protection roulement guidon	Abdeckung Lenkerslager	Proteccion cojinete manillar
21	1042650 000		Anello ferma paraolio	Stop ring	Anneau d'arrêt	Stopring	

Tav.20

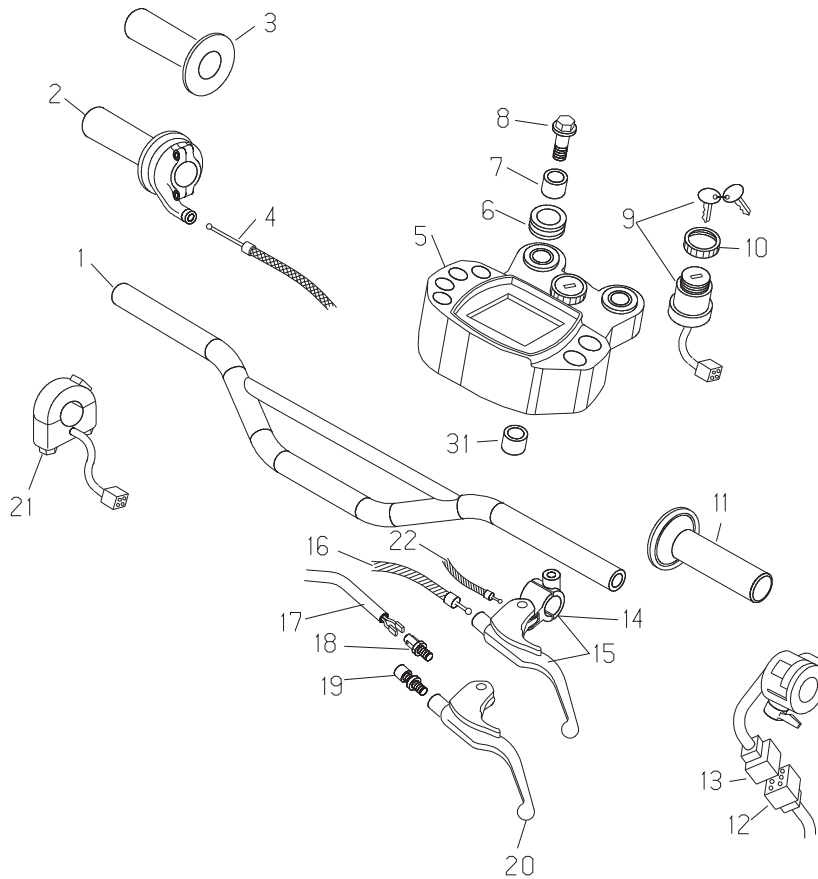

Pos Loc Pos Ps Pos	Numero Number Número Número	Nota Note Nota Anm.	Descrizione	Description	Désignation	Beschreibung	Descripció
1	2220550 059		Manubrio	Handlebars	Guidon	Lenker	Manillar
2	1208983 000		Comando gas con manopole	Twist grip	Commande gaz	Gasgriff	Mando gas
3	2218611 000		Manopole	Grips	Poignees	Lenker Griffe	Puños goma
4	2921984 052		Trasmissione gas	Throttle transmiss.	Transmission gaz	Gaszug	Transmisión gas
5	1209393 000		Conta-km digitale	Speedometer	Compteur	Tachometer	Cuenta km. tr.
6	1634902 000		Gommino strumento digitale	Rubber	Caoutchouc instrument digital	Gummidichtung digitales cockpit	Goma instrumento digital
7	1346688 000		Distanziale strumento digitale	Spacer	Entretoise	Distanz	Distanciador
8	1155440 000		Bullone 8x30 ch10 rs	Bolt 8x30	Boulon 8x30 ch10 rs	Bolzen 8x30	Tornillo 8.30 ch 10 rs
9	1255291 000		Commutat.c./chiavi e b/sterzo	Switch	Commuteur	Zuendschloss	Conmutador c/llaves y b/volante
10	1620640 000		Ghiera commutatore	Commutator grill	Grille commutateur	O-ring zuendschloss	Junta conmutador
11	2218511 000		Manopole	Grips	Poignees	Lenker Griffe	Puños goma
12	1801607 000		Impianto centrale	Electric equipment	Installation centrale	Zentraler Kabelbaum	Instalacion central
13	1336696 000		Dip luci	Switch	Commodo feux	Lichtschalter	Mando luces
14	1255005 000		Collarino fissaggio leva	Fixing rest clutch lever	Petit collier fixation levier	Befestigung f. Bremshebel	Guarnicion fijacion palanca
15	2102396 000		Leva com. frizione	Clutch lever	Levier complet embrayage	Kupplungsarmatur	Bomba embrague
16	2914765 000		Trasmissione frizione	Clutch transmission	Transmission embrayage	Kupplungsseil	Transmisión embrague
17	1801607 000		Impianto centrale	Electric equipment	Installation centrale	Zentraler Kabelbaum	Instalacion central
18	1887010 000		Interruttore stop	Stop switch	Interrupteur stop	Stopschalter	Interruptor stop
19	2726063 000		Registro leva frizione	Rectifier, clutch lever	Registre levier embrayage	Regler für Kupplungshebel	Registro palanca embrague
20	2127086 000		Leva com.friz.nuda	Clutch lever only	Levier complet embrayage nue	Kupplungshebel	Maneta embrague
21	1306511 000		Dispositivo dx	Right device	Dispositif droit	Vorrichtung re.	Dispositivo derecho
22	2924001 052		Trasmissione starter	Choke transmiss.	Transmission starter	Starterseil	Transmisión estrang.
31	1346921 000		Distanziale 8,5x17x11	Spacer 8,5x17x11	Entretoise 8,5x17x11	Distanz 8,5x17x11	Distanciador 8,5x17x11



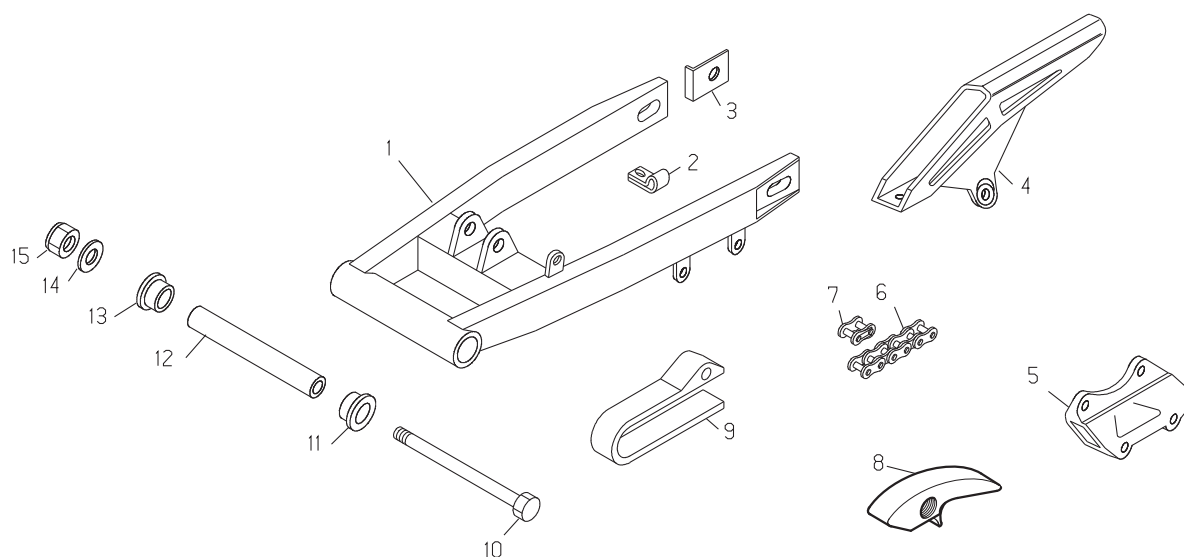

Pos Loc Pos Ps Pos	Numero Number Número Número	Nota Note Note Nota Anm.	Descrizione	Description	Désignation	Beschreibung	Descripción
1	1562099 059		Forcellone	Big fork	Fourche	Radschwinge	Horquilla
2	1514300 000		Fascetta fissaggio tubo freno	Clamp	Collier fixation tube frein arriere	Befestigungsschelle Bremsschlauch	Brida fijacion freno post.
3	2911863 000		Tendicatena	Chain tightener	Tend. de ch.	Kettenspanner	Tens. de cad.
4	1288591 159		Copricatena superiore	Up. Chain cover	Couvre-chaîne superieur	Kettenschutz oben	Cubrecadena superior
5	2910120 052		Tassello guidacatena	Sliding block	Cheville guide de chaîne	Schwingenschleifklotz	Protector cadena/basculante
6	1208170 000		Catena 1/2x5/16 p.130	Chain 1/2x5/16 p.130	Chaîne 1/2x5/16 p.130	Kette 1/2x5/16 p.130	Cadena 1/2x5/16 p.130
7	2211180 000		Maglia congiunzione 1/2x5/16	Connecting link 1/2x5/16	Maillon jonction 1/2x5/16	Kettenschloss 1/2x5/16	Enganche cadena 1/2x5/16
8	2779431 000		Pattino catena	Chain shoe	Doigt chaîne	Kettengleitauflage	Patin cadena
9	2910091 052		Tassello guidacatena super.	Upper sliding block	Cheville guide de chaîne sup.	Schwingenschleifklotz oben	Protector cadena superior
10	2555730 000		Perno forcellone	Swingarm pivot	Axe fourche AR.	Schwingenbolzen	Eje basculante
11	1122024 000		Boccola in plastica	Bush	Douille en plastique	Buchse aus Plastik	Casquillo en plastico
12	1348068 000		Distanziale 12x18x177	Spacer 12x18x177	Entretoise 12x18x177	Distanz 12x18x177	Distancidor 12x18x177
13	1122024 000		Boccola in plastica	Bush	Douille en plastique	Buchse aus Plastik	Casquillo en plastico
14	2755600 000		Rondella 12x24	Washer 12x24	Rondelle 12x24	Scheibe 12x24	Arandela 12x24
15	1321120 000		Dado autoblocc. 12x1,25	Self-blocking nut 12x1,25	Ecrou 12	Mutter 12	Tuerca 12

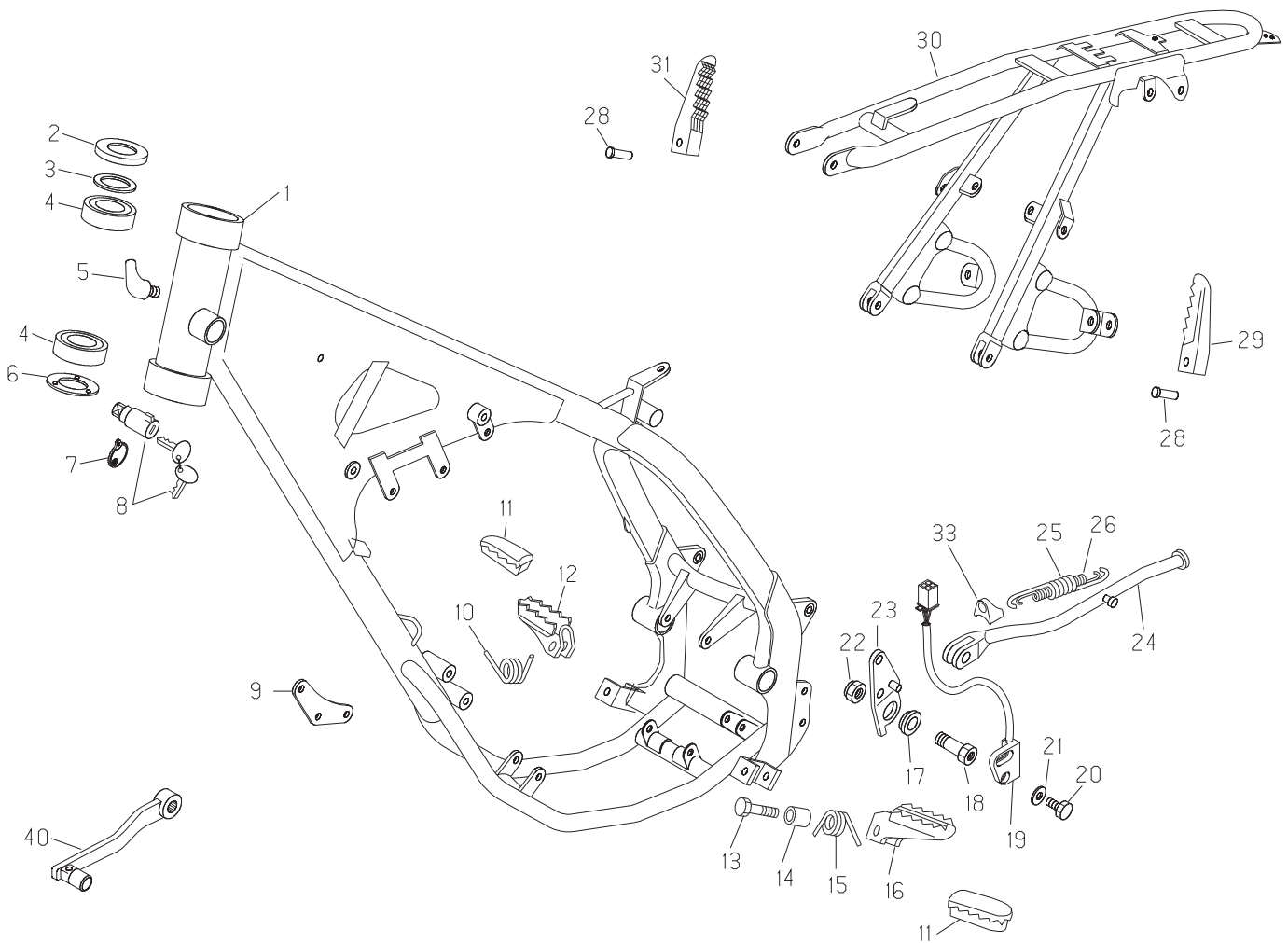

Tav.22

Pos Loc Pos Ps Pos	Numero Number Número Número Nummer	Nota Note Note Nota Anm.	Descrizione	Description	Désignation	Beschreibung	Descripción
1	2911356 025		Telaio anteriore	Front frame	Cadre avant	Gutschrift Rahmen	Chasis
2	2598781 000		Protezione cuscinetto sterzo	Ball-bearing protection	Protection roulement guidon	Abdeckung Lenkerslager	Proteccion cojinete manillar
3	2773790 000		Rondella 25,7x32,2	Washer 25,7x32,2	Rondelle 25,7x32,2	Scheibe 25,7x32,2	Arandela 25,7x32,2
4	1299300 000		Cuscinetto conico 25x47x15	Conical bearing 25x47x15	Roulement conique 25x47x15	Lager 25x47x15	Cojinete conico 25.47.15
5	2723470 000		Raccordo per sfiato	Breather pipe	Raccord pour vidange	Entlüftungsrohranschluß	Racor para ventilación
6	2598751 000		Protezione cuscinetto sterzo	Ball-bearing protection	Protection roulement guidon	Abdeckung Lenkerslager	Proteccion cojinete manillar
7	1255915 000		Coperchietto serratura sterzo	Cover lock	Petit couvercle	Deckel lenkerverschluss	Tapa
8	2885861 000		Serratura bloccasterzo	Security lock	Serrure blocage guidon	Lenkradschloss	Cerradura bloque manillar
9	2557697 000		Piastra ancoraggio motore	Plate, engine	Plaquette moteur	Halteplatte für Motor	Placa esp. Motor
10	2262010 000		Molla pedana dx	Footrest spring	Ressort repose-pied droit	Rasten/Feder re.	Muelle derch. Estribera
11	1623202 000		Gomma pedane	Rubber buffer	Caoutchouc	Gummi	Goma
12	2532520 000		Pedana poggiapiedi dx	RH footrest	Repose-pieds droit	Fußbraste re.	Estribera dhc
13	1155690 000		Bullone 8x45 ch10 rs	Bolt 8x45	Boulon 8x45 ch10 rs	Bolzen 8x45	Tornillo 8.45 ch 10 rs
14	1346530 000		Distanziale 8x12x17	Spacer 8x12x17	Entretoise 8x12x17	Distanz 8x12x17	Distanciadador 8x12x17
15	2262020 000		Molla pedana sx	Footrest spring	Ressort repose-pied gauche	Rasten/Feder li.	Muelle izqui. Estribera
16	2532503 000		Pedana poggiapiedi sx	LH footrest	Repose-pieds gauche	Fußbraste li.	Estribera izq.
17	1346350 000		Distanziale cavalletto	Spacer stand	Entretoise bequille	Distanz REV	Distanciadador caballete
18	1170015 000		Bullone spec. cavalletto	Special bolt	Boulon spec.	Spezialschraube	Tornillo especial
19	2879014 000		Sensore cavalletto	Captteur béquille	Stand sensor	Sensor	Sensor caballete
20	1148025 000		Bullone 6x16 ch 8 rs	Bolt 6x16	Boulon 6x16 ch8 rs	Bolzen 6x16	Tornillo 6x16 llave 8 rs
21	2742000 000		Rondella 6x18	Washer 6x18	Rondelle 6x18	Scheibe 6x18	Arandela 6x18
22	1318000 000		Dado 10x6	Nut 10	Ecrou 10	Mutter 10	Tuerca 10
23	2898579 000		Supporto cavalletto	Central stand support	Support béquille	Halter für Ständer	Soporte caballete
24	1239965 066		Cavalletto laterale	Side stand	Béquille latérale	Seitenständer	Caballete lateral
25	2247022 000		Molla cavalletto esterna	External stand spring	Ressort bequille extérieure	Seitenständer feder außen	Muelle caballete exterior
26	2247019 000		Molla cavalletto interna	Inner stand spring	Ressort bequille intérieure	Seitenständer feder innen	Muelle caballete interior
28	2554460 000		Perno pedana	Footrest pin	Pivot repose-pied	Rasten Pin	Eje estribera
29	2532512 000		Pedana poggiapiedi sx	LH footrest	Repose-pieds gauche	Fußbraste li.	Estribera izq.
30	2911376 025		Telaio posteriore	Rear frame	Châssis AR.	Fahrgestell hinten	Bastidor trasero
31	2532502 000		Pedana poggiapiedi dx	RH footrest	Repose-pieds droit	Fußbraste re.	Estribera dhc
33	2211003 000		Magnete sensore cavalletto	Aimant relevage capteur béq.	Stand sensor magnet	Hubmagnet Sensor	Electroiman sensor cab.
40	2121139 000		Leva comando cambio	Gearshift lever	Levier de vitesse	Schalthebel	Palanca mando cambio

RR	Versione Enduro-Version Enduro-Version Enduro-Ausführung Enduro-Versión Enduro
M	Versione Motard-Version Motard-Version Motard-Ausführung Motard-Versión Motard



Tav.23

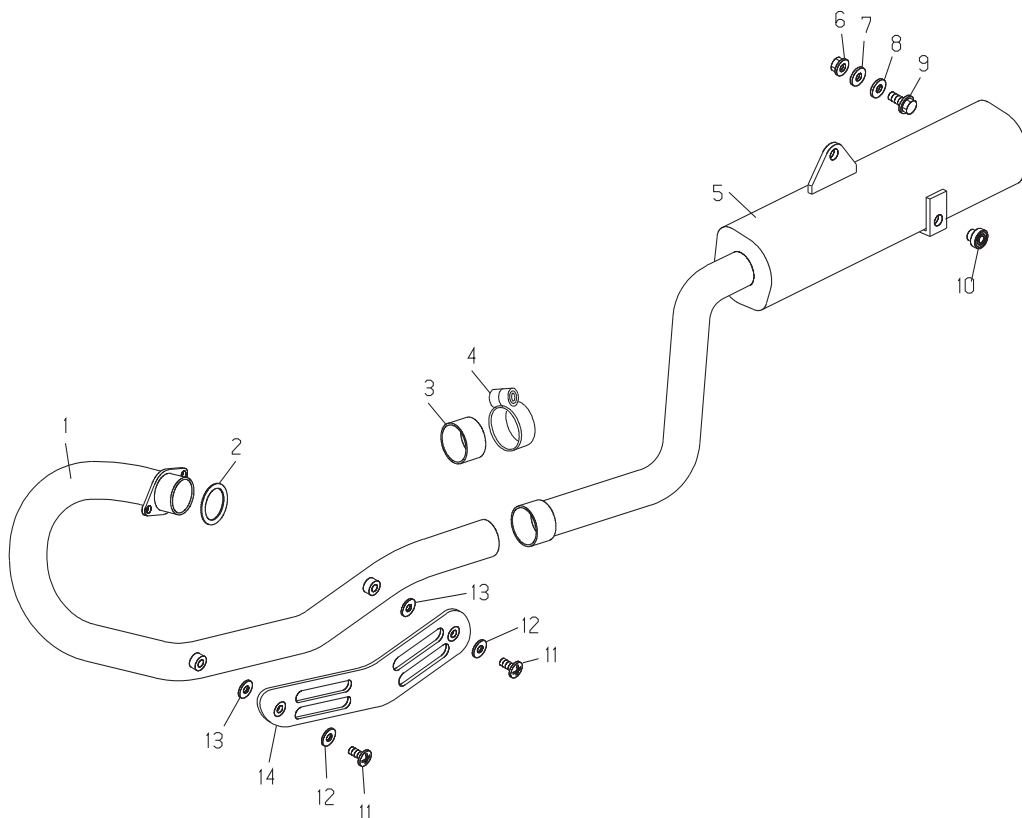

Pos Loc Pos Ps Pos	Numero Number Numéro Número Numer	Nota Note Note Nota Anm.	Descrizione	Description	Désignation	Beschreibung	Descripció
1	2916291 000		Tubo scarico	Exh.pipe	Tuyau echapp.	Krummer	Tubo de escape
2	1680818 000		Guarnizione scarico	Exhaust manifold gasket	Joint coll. Ech.	Dichtung Abgaskrümm	Junta colector de escape
3	1680816 000		Guarnizione marmitta	Exhaust gasket	Joint pot d'echappement	Dichtung	Goma silenciador
4	1514258 000		Fascetta	Clamp	Collier	Schelle	Abrazadera
5	2203419 059		Marmitta	Silencer	Silencieux	Auspufftopf	Silenciador
6	1317020 000		Dado autoblocc. Basso M8	Nut M8	Ecrou M8	Mutter M8	Tuerca M8
7	2749500 000		Rondella 8x18	Washer 8x18	Rondelle 6x18	Scheibe 8x18	Arandela 8x18
8	2749500 000		Rondella 8x18	Washer 8x18	Rondelle 6x18	Scheibe 8x18	Arandela 8x18
9	1154492 000		Bullone 8x20 ch10 rs	Bolt 8x20	Boulon 8x20 ch10 rs	Bolzen 8x20	Tornillo 8.20 ch 10 rs
10	1633781 000		Gommino protezione fiancate	Side panels protect. Grommet	Caoutchouc protection cote lateral	Gummi Schutzseiten	Goma proteccion flanco
11	3130477 000		Vite TBCE 6x15	Screw 6x15	Vis 6x15	Schraube 6x15	Tornillo
12	2774789 000		Rondella bombata	Kasher	Rondelle	Scheibe	Arandela
13	1647490 000		Guarnizione isolante 6x20x3	Gasket 6x20x3	Joint 6x20x3	Dichtung 6x20x3	Junta 6x20x3
14	2598917 014		Protezione tubo scarico	Silencer shield	Protection tube d'echappement	Abdeckung Auspuff	Proteccion tubo escarico



Beta
the play bike

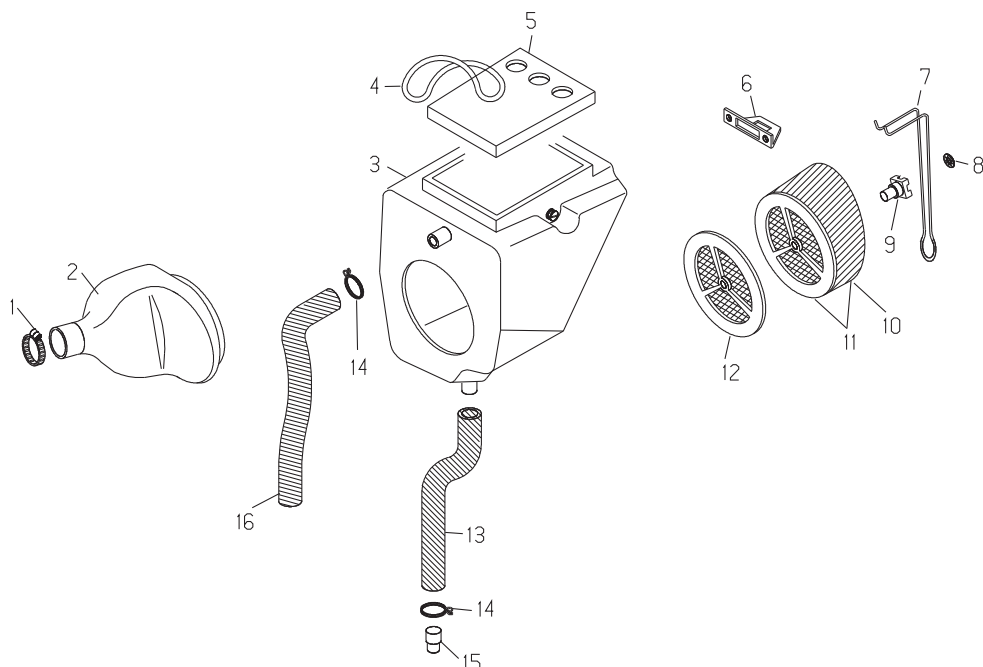

Pos Loc Pos Ps Pos	Numero Number Numéro Número Nummer	Nota Note Note Nota Anm.	Descrizione	Description	Désignation	Beschreibung	Descrìption
1	1515380 000		Fascetta 33x53	Clamp 33x53	Collier 33x53	Schlauchbinder	Brida 33/53
2	2213588 000		Manicotto scatola filtro	Filter box sleeve	Manchon boîte du filtre	Filtergehäuseumfufe	Manguito caja filtro
3	2812777 052		Scatola filtro	Filter box	Boîtier du filtre	Sicherungskasten	Caja del filtro
4	1440040 000		Elastico fissaggio	Elastic rubber	Elastique de fixation	Befestigungsband	Elastico
5	1273194 052		Coperchio accesso a filtro	Air filter cover	Couvercle filtre	Deckel Luffilterkasten	Tapa guardabarros tras. Filtro
6	2897021 000		Staffa aggancio molla filtro	Filter spring racket	Etrier ressort filtre	Halter Federsfilter	Soporte muelle filtro
7	2248820 000		Molla fermafiltro	Filter spring	Ressort filtre	Filter Feder	Muelle filtro
8	2774800 000		Rondella autobloccante 9	Washer 9	Rondelle 9	Scheibe 9	Arandela 9
9	2557197 000		Perno richiamo ferma-filtro	Filter pin	Pivot filtre	Filtershalter	Pin Eje filtro
10	1525081 000		Filtro aria	Air filter	Filtre à air	Luffilter	Filtro de aire
11	1525092 000		Gabbia filtro aria	Air filter	Filtre à air	Luffilter	Filtro de aire
12	1611216 800		Gabbia filtro aria	Filter cage	Grille filtre aire	Filter kafig	Jaula filtro aire
13	2915887 000		Tubo scarico raccolta fumi	Exhaust tube	Tube echapp. recuoerat. fumees	blausleitung motordampfe	Tubo escarico coleccion fumos
14	1067436 000		Anello stringitubo	Pipe clamping ring	Anneau serre-tube	Schlauchschele	Anillo prensatubo
15	2900486 000		Tappo tubo scarico fumi	Plug, oil emissions pipe	Bouchon pot d'echapp. fumees	Auspuffdeckel	Tapon tubo escarico fumos
16	2915816 000		Tubo MIX-C 10x15	10x15 MIX-C Tube	Tube MIX-C	Schlauch MIX-C	Tubo MIX-C 10X15

Tav.25

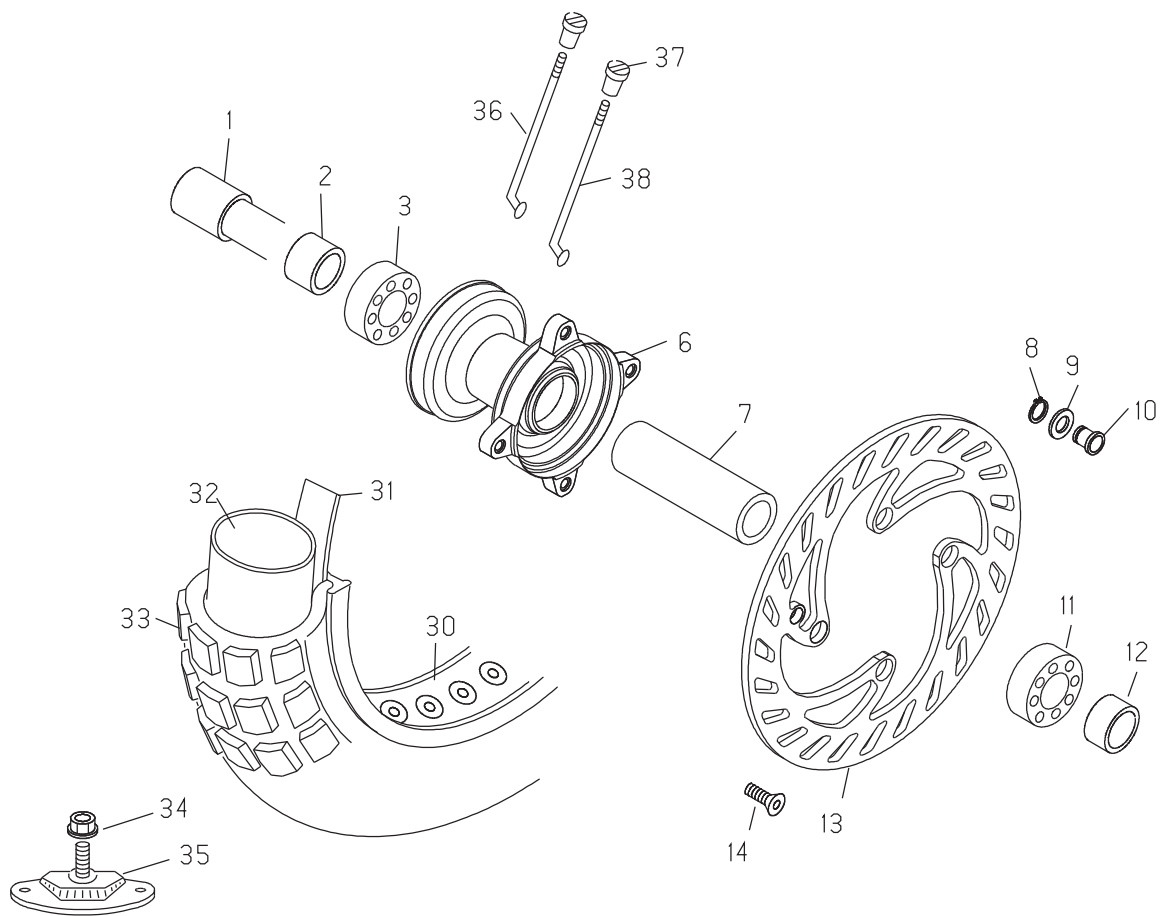

Tav.25

Pos Loc Pos Ps Pos	Numero Number Numéro Número Nummer	Nota Note Note Nota Anm.	Descrizione	Description	Désignation	Beschreibung	Descripción
1	2555741 000		Perno ruota anteriore	Front wheel spindle	Pivot roue AV.	Vorderradzapfen	Perno rueda delantera
2	1385434 000		Distanziale mozzo post. Dx	RH rear hub spacer	Entretoise moyeu arriere	Distanz li	Distanciadior buje tras.
3	1296005 000		Cuscinetto 17x40x12 stagno	Ball bearing 17x40x12	Roulement 17x40x12 etanche	Kugellager 17x40x12	Cojinete 17x40x12 blindado
6	2207251 000		Mozzo anteriore c/cuscinetti	Front hub with ballbearing	Moyeu avant avec roulements	Nabe vo.	Buje ant.c/cojinetes
7	1362728 000		Distanziale int, mozzo anter.	Front hub inner spacer	Entretoise int. moyeu avant	Distanciadior int buje del.	Distanciadior int. buje del.
8	2822660 000		Seeger 9E	Seeger 9E	Seeger 9E	Seegerring 9E	Seeger 9E
9	2758080 000		Rondella spess. 9x13x0,4	Washer 9x13x0,4	Rondelle epaisseur 9x13x0,4	Scheibe 9x13x0,4	Arandela 9x13x0,4
10	2211000 000		Magnete per sensore REED	Sensor REED magneto	Magneto capteur REED	Magnet für Sensor	Magneto sensor REED
11	1296005 000		Cuscinetto 17x40x12 stagno	Ball bearing 17x40x12	Roulement 17x40x12 etanche	Kugellager 17x40x12	Cojinete 17x40x12 blindado
12	1385073 000		Distanziale mozzo ant. Sx	LH front hub spacer	Entretoise moyeu avant	Distanz re	Distanciadior
13	1339282 000		Disco freno anteriore	Front brake disk	Disque Frein AV.	Vordere Bremsscheibe	Dsco freno del.
14	3163922 000		Vite TSPCE 8x16	Screw 8x16	Vis 8x16	Schraube 8x16	Tornillo
30	1242934 000		Cerchio 21x1,6 36 fori	Rim 21x1,6x36	Jante 21x1,6x36	Felge 21x1,6x36	Llanta 21x1,6x36
31	1538200 000		Flap 21x25	Bead 21x25	Flap 21x25	Felgenband 21x25	Flap cinta tapa radios 21.25
32	1216110 000		Camera 2.50-21/2.75-21	Tube 2,50x21-2,75x21	Tube 2,50x21-2,75x21	Schlauch 2,50x21-2,75x21	Camara 2,50x21-2,75x21
33	1279136 000		Copertura 90-90-21	Tire 90-90-21	Couverture 90-90-21	Reifen 90-90-21	Cubierta 90-90-21
34	1317120 000		Dado M8 flangiato	Nut M8	Ecrou M8	Mutter M8	Tuerca M8
35	1517500 000		Fermafascioni	Tire fastener	Caoutchouc serrure chambre	Reifen Halter	Agarre cubierta ant.
36	2723981 000		Raggio 3x240	Spoke 3x240	Rayon 3x240	Speiche 3x240	Rayo 3x240
37	2310100 000		Nipples	Nipples	Nipples	Nippel	Nipples
38	2723982 000		Raggio 3x242	Spoke 3x242	Rayon 3x242	Speiche 3x242	Rayo 3x242

Tav.26

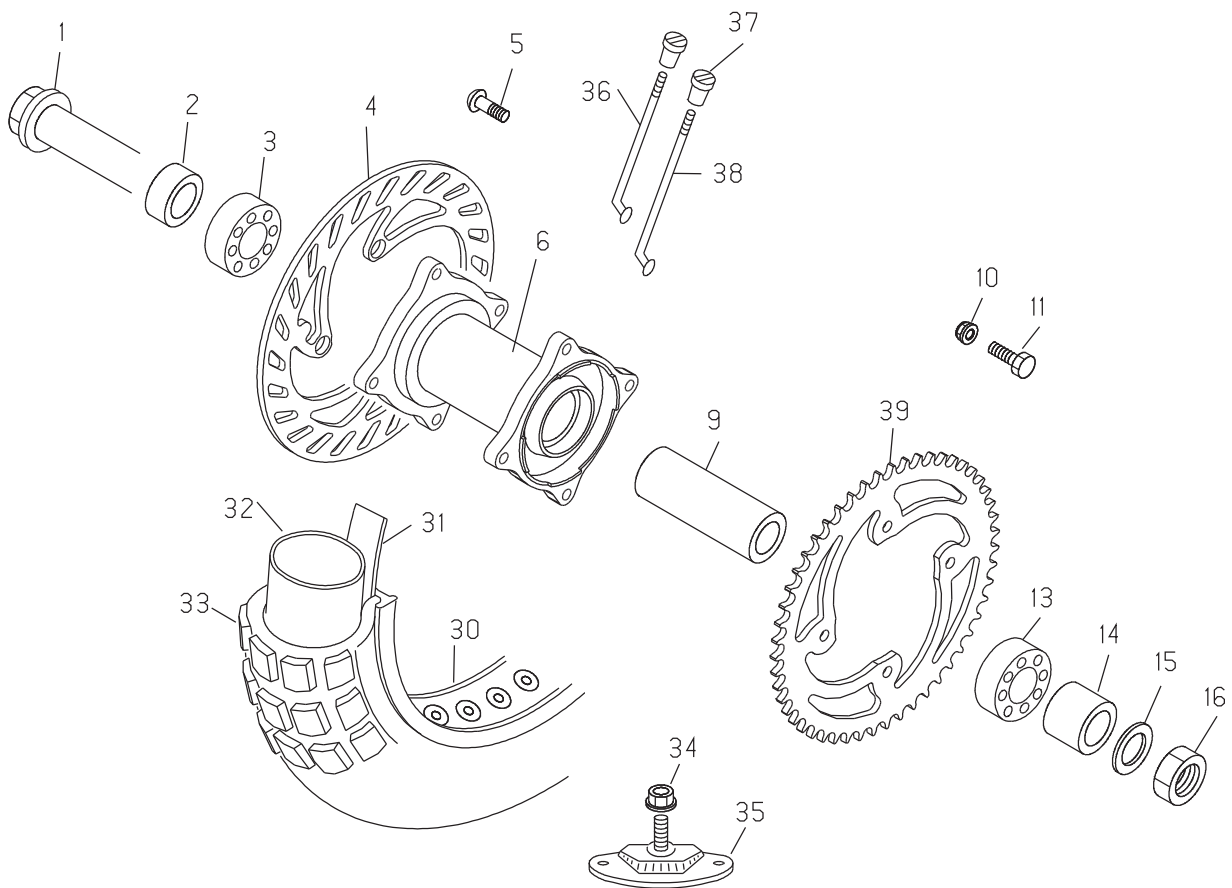

Tav.26

Pos Loc Pos Ps Pos	Numero Number Numéro Número Nummer	Nota Note Note Nota Anm.	Descrizione	Description	Désignation	Beschreibung	Descripción
1 2	2555621 000 1385728 000		Perno ruota posteriore Distanziale int, mozzo anter.	Rear wheel pin Front hub inner spacer	Pivot roue arrière Entretoise int. moyeu avant	Hinterradbolzen Distanciadior int buje del. Distanzscheibe	Perno rueda trasera Distanciadior int. buje del.
3 4 5 6 9 10 11 13 14 15 16 30 31 32 33 34 35 36 37 38 39	1297005 000 1339415 000 3130476 000 2208050 000 1362727 000 1317031 000 3164080 000 1297005 000 1385737 000 2771210 000 1329600 000 1242943 000 1536000 000 1218320 000 1281434 000 1317120 000 1517531 000 2724811 000 2724812 000 2310110 000 1289637 000		Cuscinetto 17x47x14 stagno Disco freno posteriore Vite TBCE 6x16 Mozzo posteriore c/cuscinetti Distanziale int, mozzo poster. Dado M8 autobloc -conelock- Vite flangiata 8x28 Cuscinetto 17x47x14 stagno Distanziale mozzo post. Rondella 17x33x3 Dado 16x1,5 Cerchio 18x1,85 36 fori Flap 17/18x25 Camera MD-18 Copertura 120-90-18 Dado M8 flangiato Fermafascioni Raggio 3,5x203 c.150 Raggio 3,5x206 c.150 Nipples ø3,5 Corona z.54 1/2x5/16	Ball bearing 17x47x14 Rear brake disk Screw 6x16 Rear hub with ballbearing Rear hub inner spacer Nut M8 Screw 8x28 Ball bearing 17x47x14 Spacer rear hub Washer 17x33x3 Nut 16x1,5 Rim 18x1,85x36 Bead 17/18x25 Tube MD-18 Tire 120-90-18 Nut M8 Tire fastener Spoke 3,5x203 c,150 Spoke 3,5x206 c,150 Nipples ø3,5 Ring gear z.54 1/2x5/16	Roulement 17x47x14 etanche Disque frein arrière Vis 6x16 Moyeu arriere avec roulements Entretoise int. moyeu arriere Ecrou M8 Vis avec bride 8x28 Roulement 17x47x14 etanche Entretoise moyeu arriere Rondelle 17x33x3 Ecrou 16x1,5 Jante 18x1,85x36 Flap 17/18x25 Tube MD-18 Couverture 120-90-18 Ecrou M8 Caoutchouc serrure chambre Rayon 3,5x203 c,150 Rayon 3,5x206 c,150 Nipples ø3,5 Couronne z.54 1/2x5/16	Kugellager 17x47x14 Hinterbrems Scheibe Schraube 6x16 Hinterrad Nabe Distanzscheibe Mutter M8 Schraube 8x28 Kugellager 17x47x14 Distanzscheibe Scheibe 17x33x3 Rad Mutter 16x1,5 Felge 18x1,85x36 Felgenband 17/18x25 Schlauch MD-18 Reifen 120-90-18 Mutter M8 Reifen Halter Speiche 3x203 c.150 Speiche 3x206 c.150 Nippel ø3,5 Zahnkranz z.54 1/2x5/16	Cojinete 17x47x14 blindado Disco freno trasero Tornillo Buje del. c/cojinetes Distanciadior int. Buje tras. Tuerca M8 Tornillo especial 8.28 Cojinete 17x47x14 blindado Dist. buje tras. der. l/corona Arandela 17x33x3 Tuerca 16.1,5 Llanta 18x1,85x36 Flap cinta tapa radios 17/18x25 Camara MD-18 Cubierta 120-90-18 Tuerca M8 Agarre cubierta ant. Rayo 3,5x203 c. 150 Rayo 3,5x206 c. 150 Nipples 3,5 Corona z.54 1/2x5/16

Tav.27

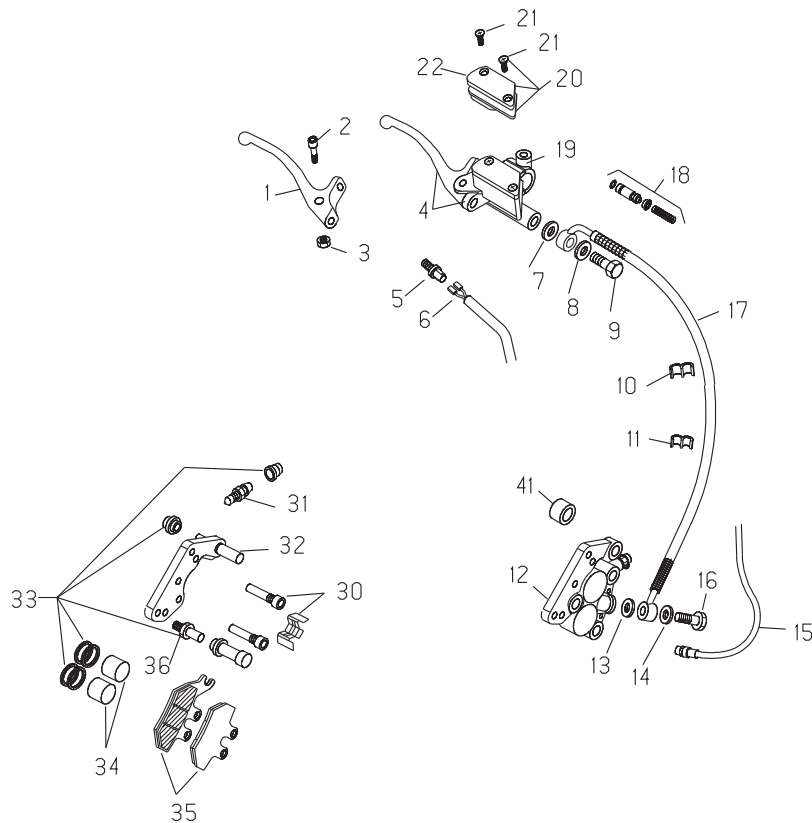

Pos Loc Pos Ps Pos	Numero Number Numéro Número Nummer	Nota Note Note Nota Anm.	Descrizione	Description	Désignation	Beschreibung	Descripció
1	2127105 000		Leva freno anter.nuda	Front brake lever only	Levier frein avant nue	Bremshebel	Maneta freno
2	3196818 000		Vite spec. X leva freno-frizione	Screw	Vis	Schraube	Tornillo
3	1311510 000		Dado 6x4 ch10	Nut 6x4	Ecrou 6x4 ch10	Mutter 6x4	Tuerca 6x4 llave 10
4	2102064 000		Leva com. freno anter.	Front brake lever	Levier complet frein avant	Bremsarmatur	Bomba freno delantero
5	1887000 000		Interruttore stop	Stop switch	Interrupteur stop	Stopschalter	Interruttore stop
6	1801607 000		Impianto centrale	Electric equipment	Installation centrale	Zentraler Kabelbaum	Instalacion central
7	1650510 000		Guarnizione 10x15x1 in rame	Gasket 10x15x1 copper	Joint 10x15x1 cuivre	Dichtung 10x15x1 Kupfer	Junta 10.15.1 (cobre)
8	1650510 000		Guarnizione 10x15x1 in rame	Gasket 10x15x1 copper	Joint 10x15x1 cuivre	Dichtung 10x15x1 Kupfer	Junta 10.15.1 (cobre)
9	1165040 000		Bullone forato 10x1 x tubo freno	Special bolt	Boulon 10x1 x tube frein	Hohlschraube F.Bremse	Tornillo esp. talad.10.1
10	2524442 000		Passacavo 6/8	Fair lead 6/8	Passe-fils 6/8	Kabelführung 6/8	Pasa-cable 6/8
11	2524443 000		Passacavo 6/6	Fair lead 6/6	Passe-fils 6/6	Kabelführung 6/6	Pasa-cable 6/6
12	2503087 000		Pinza freno anteriore	Front disk brake caliper	Etrier de frein AV.	Bremszange-Scheibe	Pinza freno del.
13	1650510 000		Guarnizione 10x15x1 in rame	Gasket 10x15x1 copper	Joint 10x15x1 cuivre	Dichtung 10x15x1 Kupfer	Junta 10.15.1 (cobre)
14	1650510 000		Guarnizione 10x15x1 in rame	Gasket 10x15x1 copper	Joint 10x15x1 cuivre	Dichtung 10x15x1 Kupfer	Junta 10.15.1 (cobre)
15	2879013 000		Sensore REED	REED sensor	Sensor REED	Sensor	Sensor REED
16	1165040 000		Bullone forato 10x1 x tubo freno	Special bolt	Boulon 10x1 x tube frein	Hohlschraube F.Bremse	Tornillo esp. talad.10.1
17	2909524 000		Tubo freno anteriore	Front brake tube	Tuyau du frein AV.	Vordere Bremsleitung	Tubo freno delantero
18	2005061 000		Kit pistoncini leva	Piston kit	Jeu petit piston levier	Kolbensatz hauptbr.zyl	Juego pistones palanca
19	1230103 000		Cappello fissaggio pompa	Holder	Capuchon levier frein	Druckplatte f.	Pumpe Tapa fijación bomba
20	2008267 000		Kit ricambi pompa freno	Kit (spare-part)brake pump	Jeu pieces pompe frein	Reparatursatz Bremspumpe	Juego piezas bomba freno
21	3196810 000		Vite TSPIK 4X12	Screw	Vis	Schraube	Tornillo
22	1255911 000		Coperchio pompa freno	Pump cover	Couvercle pompe	Deckel	Tapa bomba
30	2008271 000		Kit ricambi pinza	Kit (spare parte)	Jeu pieces	Reparatursatz Zange	Juego piezas pinza
31	3196801 000		Vite spurgo pinza	Special screw	Vis pour pince	Spezial schraube	Tornillo aliento pinza
32	2898119 000		Supporto pinza freno	Brake plier support	Support pince frein	Bremszange Halter	Soporte pinza freno
33	2008269 000		Kit ricambi pompa freno	Kit (spare-part)brake pump	Jeu pieces pompe frein	Reparatursatz Bremspumpe	Juego piezas bomba freno
34	2569444 000		Pistoncino pompa	Brake pliers piston	Piston etrier	Kolben für Pumpe	Piston bomba
35	2525340 000		Pastiglie per pinza	Brake pads	Plaquettes pince	Bremsbeläge hinten	Pastillas pinza
36	2541854 000		Perno ancoraggio pinza	Plier pin	Pivot ancrage etrier	Zangshalter	Varilla esp. Pinza
41	1349197 000		Distanziale	Spacer	Entretoise	Distanz	Distanciador



Beta
the play bike

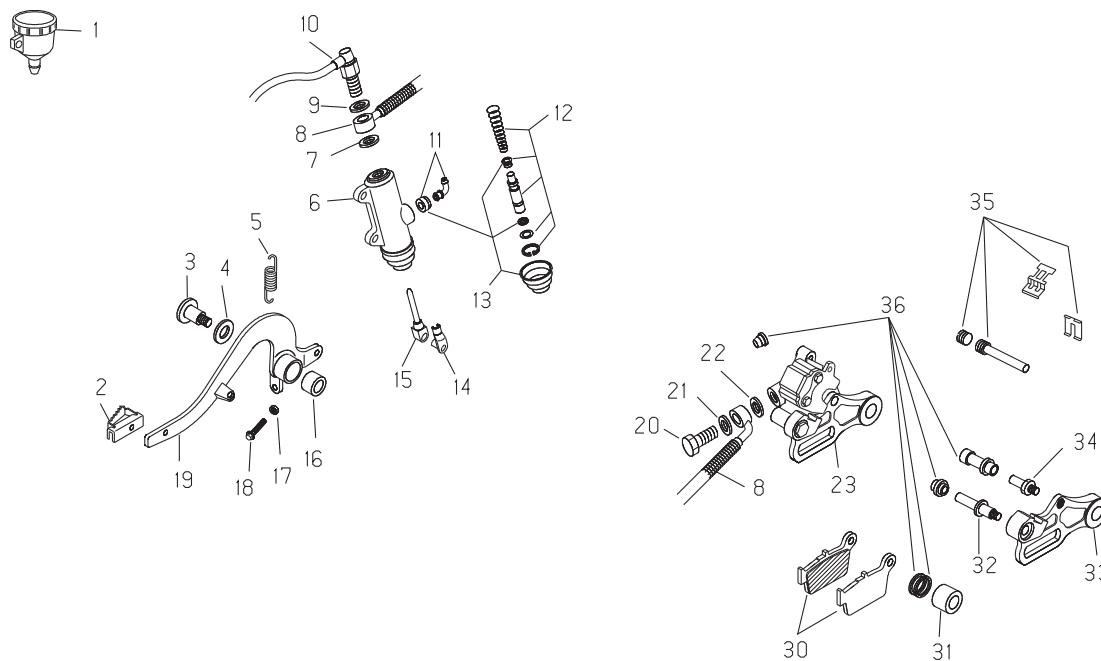

Pos Loc Pos Ps Pos	Numero Number Número Nummer	Nota Note Nota Anm.	Descrizione	Description	Désignation	Beschreibung	Descrìption
1	2805100 000		Serbatoio olio freni	Brake oil tank	Réservoir huile frein	Bremsflüssigkeitstank	Depósito aceite frenos
2	2290051 000		Mozzetto con pedana	Footrest hub	Moyeu a/repose pieds	Rasten Nabe Fußbremshebel	Puntera pedal freno
3	1164601 000		Bullone spec. ped. Freno	Special bolt	Boulon spec.	Spezial Bolzen	Tornillo special
4	2764500 000		Rondella spess. 15x25	Washer 15x25	Rondelle epaisseur 15x25	Scheibe 15x25	Arandela 15x25
5	2248810 000		Molla ritorno pedale freno	Return brake pedal spring	Ressort de retour frein	Bremspedal Feder	Muelle retorno palanca freno
6	2591177 000		Pompa freno posteriore	Rear brake cylinder	Maître cylindre frein ar.	Hauptbremszylinder Hinterradbremse	Bomba freno trasero
7	1650510 000		Guarnizione 10x15x1 in rame	Gasket 10x15x1 copper	Joint 10x15x1 cuivre	Dichtung 10x15x1 Kupfer	Junta 10.15.1 (cobre)
8	2909512 000		Tubo freno disco posteriore	Rear brake hose	Tube frein a disque arriere	hi. Bremsleitung	Tubo freno disco post.
9	1650510 000		Guarnizione 10x15x1 in rame	Gasket 10x15x1 copper	Joint 10x15x1 cuivre	Dichtung 10x15x1 Kupfer	Junta 10.15.1 (cobre)
10	1889622 000		Interruttore stop	Stop switch	Interrupteur stop	Stopschalter	Interruptor stop
11	2008268 000		Kit ricambi pompa freno	Kit (spare-part)brake pump	Jeu pieces pompe frein	Reparatursatz Bremspumpe	Juego piezas bomba freno
12	2569456 000		Pistoncino completo pompa	Piston assy, pump	Piston compl. pompe	Kolben klpt. Pumpe	Piston completo bomba
13	2002707 000		Kit guarnizioni pompa	Master cyl. packings kit	Jeu joints maître cyl.	Dichtungensatz Hauptbremszylinder	Grupo juntas bomba
14	2893130 000		Staffa	Bracket	Support	Halterung	Soporte
15	1084040 000		Asta com.pompa freno post	Rear brake rod	Tige de commande pompe frein	Betaetigungsstange Bremse hi.	Varilla bomba freno post.
16	1131031 000		Boccola sinterizz. 14x18x155	Sintered bush 14x18x15	Douille frittée 14x18x15	Hülse 14x18x15	Casquillo 14x18x15
17	1313000 000		Dado 6x6 ch10	Nut 6x6	Ecrou 6x6 ch10	Mutter 6x6	Tuerca 6x6 llave 10
18	1150300 000		Bullone 6x30 ch rs	Bolt 6x30	Boulon 6x30 ch rs	Bolzen 6x30	Tornillo 6.30 ch rs
19	2526224 000		Pedale freno	Brake pedal	Pédale frein	Fussbremspedal	Pedal freno
20	1165040 000		Bullone forato 10x1 x tubo freno	Special bolt	Boulon 10x1 x tube frein	Hohlschraube F.Bremse	Tornillo esp. talad.10.1
21	1650510 000		Guarnizione 10x15x1 in rame	Gasket 10x15x1 copper	Joint 10x15x1 cuivre	Dichtung 10x15x1 Kupfer	Junta 10.15.1 (cobre)
22	1650510 000		Guarnizione 10x15x1 in rame	Gasket 10x15x1 copper	Joint 10x15x1 cuivre	Dichtung 10x15x1 Kupfer	Junta 10.15.1 (cobre)
23	2503073 000		Pinza freno posteriore	Rear disk brake caliper	Etrier de frein AR.	Bremszange	Pinza del freno tras.
30	2525345 000		Pastiglie per pinza	Brake pads	Plaquettes pince	Bremsbeläge hinten	Pastillas pinza
31	2569459 000		Pistoncino pompa	Brake pliers piston	Piston etrier	Kolben für Pumpe	Piston bomba
32	2541856 000		Perno ancoraggio pinza	Plier pin	Pivot ancrage etrier	Zangshalter	Varilla esp. Pinza
33	2898121 000		Supporto pinza freno	Brake plier support	Support pince frein	Bremszange Halter	Soporte pinza freno
34	2541854 000		Perno ancoraggio pinza	Plier pin	Pivot ancrage etrier	Zangshalter	Varilla esp. Pinza
35	2008273 000		Kit ricambi pinza	Kit (spare parte)	Jeu pieces	Reparatursatz Zange	Juego piezas pinza
36	2008272 000		Kit ricambi pinza	Kit (spare parte)	Jeu pieces	Reparatursatz Zange	Juego piezas pinza

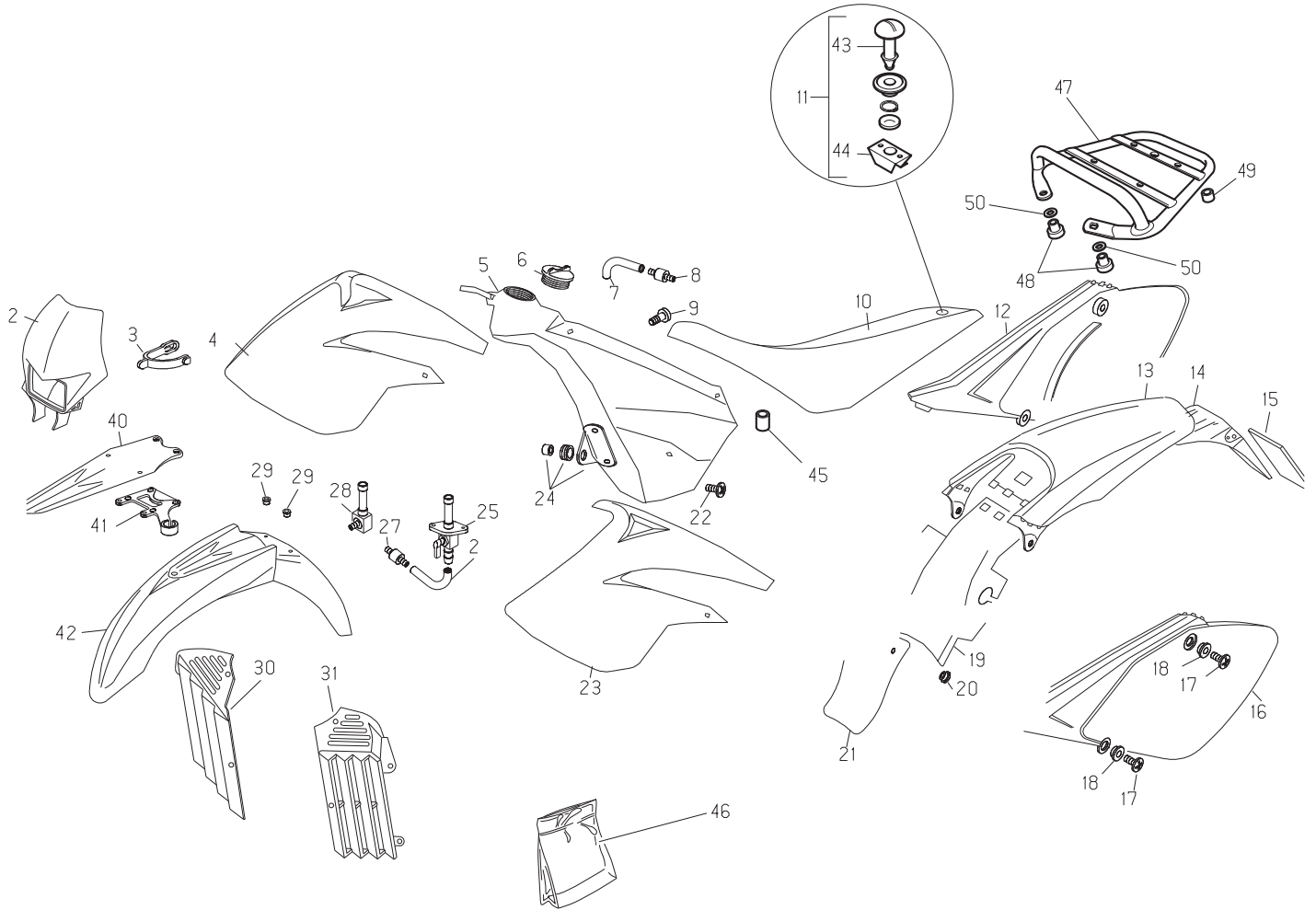

Tav.29

Pos Loc Pos Ps Pos	Numero Number Numéro Número Nummer	Nota Note Note Nota Anm.	Descrizione	Description	Désignation	Beschreibung	Descrìcion
2	2228471 151		Mascherina portafaro	Headlight holder	Cache porte-phare	Lampenmaske	Portafaro ant. con adhesivo
3	1440083 000		Elastico fissaggio mascherina	Headlight holder elastic rubber	Elastique de fixation cache phare	Befestigungsband Lichtschildchen	Elastico
4	1523112 151		Fianchetto serbatoio dx	RH tank panel	cote lateral reservoir droite	Benzintankseite re.	Flanco derecho deposito
5	2806034 059		Serbatoio benzina	Fuel tank	Reservoir carb.	Kraftstofftank	Dep. carburante
6	2910511 000		Tappo serb. benzina	Gasoline tank plug	Bouchon reservoir	Tankdeckel	Tapon deposito gasolina
7	2915811 000		Tubo benzina 5x9	Gasoline tube 5x9	Tube essence 5x9	benzinschlauch 5x9	Tube gasolina 5x9
8	3102170 000		Valvola sfianto serbatoio	Reservoir breather valve	Reniflard réservoir	Behälterentlüftungsventil	Válvula alivio depósito
9	3189010 000		Vite spec. bloccaggio sella	Seat locking screw	Vis blocage selle	Schraube	Tornillo bloqueo sillin
10	2801649 000		Sella	Seat	Siege	Sattel	Sillin
11	2002044 000		Kit chiusura sella	Fixing saddle	kit Jeu fermeture pour selle	Befestigungskit	Juego cierre sillin
12	1519841 151		Fiancata portanumero dx	RH side panel	Cote lateral droite porte-numero	Nummershalterseite re.	Flanco lateral derecho
13	2519667 151		Parafango posteriore	Rear mudguard	Garde-boue AR.	Hinterradkotflügel	Guardabarros tras.
14	2594477 159		Portatarga	Plate holder	Porte-plaque	Kennzeichenträger	Porta matr.
15	2898476 000		Supporto targa	Licence plate bracket	Support plaque	Nummernschildträger	Soporte placa porta matricula
16	1519851 151		Fiancata portanumero sx	LH side panel	Cote lateral gauche porte-numero	Nummershalterseite li.	Flanco lateral izquierdo
17	1149070 000		Bullone 6x20 ch rs	Bolt 6x20	Boulon 6x20 ch rs	Bolzen 6x20	Tornillo 6.20 ch rs
18	1362000 000		Distanziale	Spacer	Entretoise	Distanzstück	Distanciador
19	2524657 151		Passaruota	Rear wheel house	Passe-roue	Radführung	Passaruota
20	1354510 000		Distanziale	Spacer	Entretoise	Distanzstück	Distanciador
21	2524410 000		Paraschizzi scatola filtro	Filter box mudguard	Cache-taches boite de filtre	Spritzschutz Luftfilter	Faldon goma caja filtro
22	3130580 000		Vite TTLIC 6x12 testa 12	Screw 6x12	Vis 6x12	Schraube 6x12	Tornillo tlic 6.12 cabeza 12
23	1523102 151		Fianchetto serbatoio sx	LH tank panel	Cote lateral reservoir gauche	Benzintankseite li.	Flanco izquierdo
24	2595220 000		Piastra fissaggio serbatoio	Bracket	Plaque fixation reservoir	Halplatte benzintanke	Placa fijacion deposito
25	2779830 000		Rubinetto benzina	Fuel cock.	Robinet melange	Kraftstoffhahn	Grifo mezcla
26	2915815 000		Tubo benzina 5x10	Gasoline tube 5x10	Tube essence 5x10	Benzin Schlauch 5x10	Tube gasolina 5x10
27	1524651 000		Filtro benzina	Fuel filter	Filtre à essence	Benzinfilter	Filtro mezcla
28	2711260 000		Raccordo con filtro olio	Connector with oil filter	Raccord avec filtre a huile	Anschlussstueck m. oelfilter	Enlace con filtro aceite
29	1349190 000		Distanziale	Spacer	Entretoise	Distanzstück	Distanciador
30	1645552 159		Griglia serbatoio dx	RH tank grill	Grille reservoir droit	Kuehlervorverkleidung RE	Junta deposito derecho
31	1645553 159		Griglia serbatoio sx	LH tank grill	Grille reservoir gauche	Kuehlervorverkleidung LI	Junta deposito izquierdo
40	2898278 133		Supporto parafango anteriore	Front fender racket	Support garde-boue avant	Kotflügelhalter vorne	Soporte guardabarros ant.
41	2557255 136		Piastra per tubo freno anter.	Front brake tube plate	Plaque tube frein avant	Halteplatte Bremsschlauch	Placa tubo freno anterior
42	2514338 151		Parafango anteriore	Front mudguard	Garde boue AV.	Vorderradkotflügel	Guardabarros anterior
43	2544080 000		Perno	Pin	Pivot	Zapfen	Perno
44	2731730 000		Ricettacolo chiusura sella	Receptacle	Réceptacle	Behälter	Receptaculo
45	1348861 000		Distanziale	Spacer	Entretoise	Distanzstück	Distanciador
46	1332389 051		Decalco (serie)	Transfer set	Serie decalco	Serie Aufkleber	Serie adhesivos
47	2592943 026		Portapacchi posteriore	Rear luggage carrier	Porte-bagages Ar.	Gepäckträger, hinten	Porta-equipajes trasero
48	1346412 000		Distanziale	Spacer	Entretoise	Distanzstück	Distanciador
49	1346408 000		Distanziale	Spacer	Entretoise	Distanzstück	Distanciador
50	2742505 000		Rondella in gomma	Rubber washer	Rondelle en caoutchouc	Gummiunterlegscheibe	Arandela de goma

Tav.30

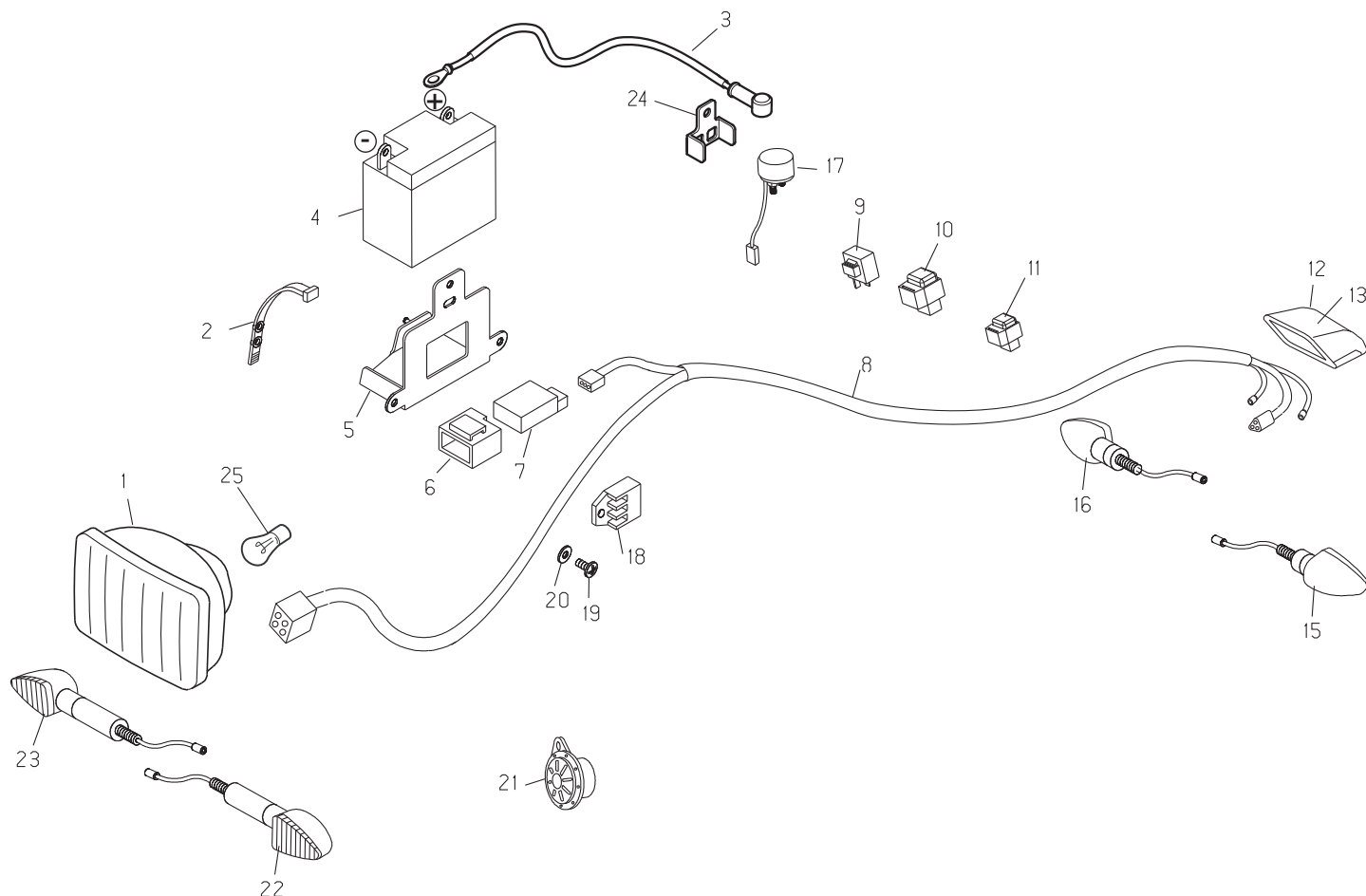

Pos Loc Pos Ps Pos	Numero Number Numéro Número Numer	Nota Note Note Nota Anm.	Descrizione	Description	Désignation	Beschreibung	Descripción
1	1646202 000		Gruppo ottico RR-4T	Headlight RR4T	Groupe optique	Optischer Block	Grupo optico
2	1440030 000		Elastico fissaggio	Elastic rubber	Elastique de fixation	Befestigungsband	Elastico
3	1801609 000		Impianto batteria-relais	Electric equipment	Systeme electrique	Kabelbaum	Instalacion electrica
4	1115415 000		Batteria	Battery	Batterie	Batterie	Bateria
5	2811793 025		Scatola portabatteria	Battery box	Boîte porte-batterie	Batteriekasten	Escatola bateria
6	2897897 000		Guscio Centralina	ECU Shell	Enceinte Boîtier Electronique	Steuergerätverschalung	Carcasa Central
7	1241854 000		Centralina elettronica	Electronic control unit (ECU)	Centrale	Elektronisches Steuergerät	Centralita electrónica
8	1801607 000		Impianto centrale	Electric equipment	Installation centrale	Zentraler Kabelbaum	Instalacion central
9	1884946 000		Intermittenza	Unit turn signal lamps	Disp. comm. clignot.	Blinkgeber	Disp. intermitentes
10	2728473 000		relais cavalletto	Relai assy side stand	Relais bequille	Relais Ständer	Relais caballete
11	1566611 000		Fusibile	Fuse	Fusible	Sicherung	Fusible
12	1501766 000		Fanalino posteriore	Rear combination lamp	Feu AR.	Rücklicht	Piloto
13	1281703 000		Coppetta fanalino posteriore	Indicator lens	Boite feu arriere	Rücklichtschutz	Proteccion luz posterior
15	1812624 000		Indicatore direzione post. sx	LH rear indicator	Indicateur arriere gauche	Blinker hinten li.	flecha posterior izquierda
16	1812621 000		Indicatore direzione post. dx	RH rear indicator	Indicateur arriere droit	Blinker hinten re.	flecha posterior derecha
17	2728474 000		Relè avviamento	Relais de demarrage	Starter relay	Anlassrelais	Relé de arranque
18	2728104 000		Regolatore	Regulator	Régulateur	Regler	Regulador
19	3130580 000		Vite TTLIC 6x12 testa 12	Screw 6x12	Vis 6x12	Schraube 6x12	Tornillo ttilic 6.12 cabeza 12
20	2740500 000		Rondella 6x13	Washer 6x13	Rondelle 6x13	Scheibe 6x13	Arandela 6x13
21	1009171 000		Avvisatore acustico	Warning horn	Avertisseur sonore	Hupe	Claxon
22	1812614 000		Indicatore direzione ant. sx	LH front indicator	Indicateur avant gauche	Blinker vorne li.	Flecha anterior izquierda
23	1812611 000		Indicatore direzione ant. dx	RH front indicator	Indicateur avant droit	Blinker vorne re.	Flecha anterior derecha
24	2898013 000		Supporto relè avviamento	Support relais de demarrage	Starter relay bracket	Anlassrelaishalter	Soporte relé de arranque
25	2115485 000		Lampadina 12V 60/55W	Bulbo 12V 60/55W	Ampoule 12V 60/55W	Lampe 12V 60/55W	Lámpara 12V 60/55W



Tav.31

Pos Loc Pos Ps Pos	Numero Number Número Número	Nota Note Nota Anm.	Descrizione	Description	Désignation	Beschreibung	Descripción
0	1233062 000		Catadiottro laterale	Lateral reflector	Catadioptré latéral	Rückstrahler seitlich	Catafaros lateral
0	1233086 000		Catadiottro posteriore	Rear reflector	Catadioptré AR.	Rückstrahler hinten	Catafaro tras.
0	1267928 000		Carter Catena	Chain guard	Carter chaîne	Kettengehäuse	Carter cadena
0	1331445 8		Decalco coperchio motore	Engine cover transfer	Dècalcomanie pour couvercles	Abziehbild motordeckel	Calcomania tapa motor
0	1346687 000		Distanziale	Spacer	Entretoise	Distanzstück	Distanciador
0	1502512 000		Feltro isolante	Soundproofing felt	Feutre isolant	Daemmaterial seitenteil li	Fieltro aislante
0	1502515 000		Feltro isolante	Soundproofing felt	Feutre isolant	Daemmaterial seitenteil li	Fieltro aislante
0	2702610 059		Ruota anteriore p/montata	Front wheel ass.	Roue avant p/monte'	Vormontiertes vorderrad	Rueda delantera montada
0	2702610 459		Ruota anteriore p/montata	Front wheel ass.	Roue avant p/monte'	Vormontiertes vorderrad	Rueda delantera montada
0	2704870 059		Ruota posteriore p/montata	Front wheel ass.	Roue arriere p/monte'	Vormontiertes hinterrad	Rueda trasera montada
0	2704870 459		Ruota posteriore p/montata	Front wheel ass.	Roue arriere p/monte'	Vormontiertes hinterrad	Rueda trasera montada
0	2892925 000		Specchio retrovisore sx	LH rear view mirror	Retroviseur gauche	Rückspiegel li.	Espejo retrovisor izquierdo
0	2892927 000		Specchio retrovisore dx	RH rear view mirror	Retroviseur droit	Rückspiegel re.	Espejo retrovisor derecho



